

Atmospheric Vent Residential Gas Water Heater

Features

- **Defender Safety System®**—Designed to be the safest & most reliable flammable vapor ignition resistant system in the industry with a proven track record since 2003. Featuring an advanced ScreenLok® technology flame arrestor design, resettable thermal switch, sight window, and designed to be maintenance-free.
- **Bradford White ICON System®***—Intelligent gas control with no need for external electricity. Proprietary algorithms provide tighter temperature differential and consistent water temperature levels up to 160°F (71°C). LED light indicates operation status/service required.
- **Vitraglas® Lining with Microban®**—An exclusively engineered enamel formula that provides superior tank protection from the corrosive effects of water; and with Microban® antimicrobial product protection to help prevent the growth of bacteria, mold and mildew on the surface of the tank lining.
- **Hydrojet® Total Performance System**—Sediment reducing device that also increases first hour rating of hot water while minimizing temperature build-up in tank.

Additional Details

- **3x4 “Snap Lock” Draft Diverter**—Allows 3" (76mm) or 4" (102mm) vent connections with inputs of 40,000 BTU/Hr. or less. Over 40,000 BTU/Hr. has the 4" (102mm) “Snap Lock” Draft Diverter.
- **Insulation System**—Non-CFC foam covers the tank, reducing heat loss, energy consumption, and improves efficiency and jacket rigidity.
- **Pedestal Base**—Rugged and durable base allows easy transport and positioning while providing corrosion-resistant contact with floor.
- **Water Connections**—NPT factory-installed dielectric waterway with heat traps.
- **Protective Anode Rod**—Provides added protection against corrosion for long-term, trouble-free service.
- **T&P Relief Valve**—Installed.
- **Low Restrictive Brass Drain Valve**—Durable tamper proof design.
- **NOx Emissions**—Less than 40 ng/J.
- **Small Diameter Models Available**—For limited space installations.

*May vary by region



Photo is of RG240T6N

Bradford White
DEFENDER
Safety System

BRADFORD WHITE
ICON
System

VITRAGLAS
SUPERIOR PROTECTION SINCE 1941
+
MICROBAN

Hydrojet



6 or 10-Year Limited Tank Warranties / 6-Year Limited Warranty on Component Parts.

For more information on warranty, please visit www.bradfordwhite.com

For products installed in USA, Canada, and Puerto Rico. See complete copy of the warranty included with the heater for limitations.

Microban® antimicrobial product protection helps prevent the growth of bacteria, mold and mildew that may affect the product. The built-in antimicrobial properties do not protect users or others from disease-causing organisms. Microban® is a registered trademark of Microban Products Company.

Atmospheric Vent Residential Gas Water Heater

SPECIFICATIONS

Natural Gas and Liquid Propane Gas

These water heaters meet or exceed all or portions of (where applicable) the minimum efficiency requirements of ASHRAE Standard 90.1 (latest edition). C.E.C. Listed. Recovery efficiency ranging up to 80%.

Model Number	Rated Nominal Volume		DOE Rated Storage Volume Gal.	BTU/Hr. Input	LP BTU/Hr. Input	First Hour Rating Gal.	Uniform Energy Factor	Recovery at 90°F Rise*				Model Number	Rated Nominal Volume		DOE Rated Storage Volume Liters	kW Input	LP kW Input	First Hour Rating Liters	Uniform Energy Factor	Recovery at 50°C Rise*	
	U.S. Gal.	Imp. Gal.						U.S. GPH	Imp. GPH	U.S. GPH	Imp. GPH		U.S. Liters	Imp. Liters						Liters/Hour	Liters/Hour
RG130T6N*	30	25	29	27,000	27,000	46	0.54	29	24	29	24	RG130T6N*	114	110	7.9	7.9	174	0.54	110	110	
RG230T6N*	30	25	29	32,000	31,000	60	0.60	34	28	33	23	RG230T6N*	114	110	9.4	9.1	227	0.60	129	125	
RG230S6N	30	25	29	30,000	26,000	49	0.54	32	37	32	27	RG230S6N	114	110	8.8	7.6	186	0.54	121	121	
RG140T6N*	40	33	38	34,000	34,000	64	0.59	37	31	37	31	RG140T6N*	151	144	10.0	9.9	243	0.59	139	139	
RG240T6N*	40	33	38	40,000	36,000	75	0.64	43	36	34	33	RG240T6N*	151	144	11.7	10.6	284	0.64	163	129	
RG240S6N*	40	33	38	40,000	38,000	69	0.58	43	36	41	34	RG240S6N*	151	144	11.7	11.1	262	0.58	163	155	
RG150T6N*	50	42	47	34,000	34,000	75	0.63	37	31	37	31	RG150T6N*	189	178	10.0	9.9	284	0.63	139	139	
RG250T6N*	50	42	48	40,000	36,000	81	0.63	43	36	41	34	RG250T6N*	189	182	11.7	10.6	307	0.63	163	155	
RG250L6N	48	40	47	40,000	38,000	77	0.63	43	36	41	34	RG250L6N	182	178	11.7	11.1	292	0.63	163	155	
RG250S6N*	50	42	47	50,000	48,000	75	0.63	54	45	52	45	RG250S6N*	189	178	14.7	14.1	284	0.63	204	197	

Model Number	A Floor to Exhaust Conn. in.	B Jacket Dia. in.	C Vent Size in.	D Floor to T&P Conn. in.	E Floor to Gas Conn. in.	F Floor to Top of Heater in.	G Floor to Water Conn. in.	H Depth in.	J C/L of Water Conn. in.	M Water Conn. NPT in.	S Gas Conn. Size in.	Approx. Shipping Weight lbs.
RG130T6N*	59 3/4	16	3 or 4	49 3/4	13	56 1/4	57	19 1/2	8	3/4	1/2	106
RG230T6N*	59 3/4	18	3 or 4	49 3/4	13	56 1/4	57	21 1/2	8	3/4	1/2	116
RG230S6N	49 1/4	20	3 or 4	38 7/8	13	45 3/4	46 1/2	23 1/2	8	3/4	1/2	113
RG140T6N*	61 5/16	18	3 or 4	51 5/8	13	57 13/16	59 9/16	21 1/2	8	3/4	1/2	132
RG240T6N*	60 1/8	20	3 or 4	49 3/4	13	56 5/8	57 3/8	23 1/2	8	3/4	1/2	134
RG240S6N*	51 9/16	22	3 or 4	41 1/16	13	48 1/16	48 13/16	25 1/2	8	3/4	1/2	139
RG150T6N*	60 1/8	20	3 or 4	49 15/16	13	56 5/8	57 3/8	23 1/2	8	3/4	1/2	148
RG250T6N*	60 1/8	22	3 or 4	49 15/16	13	56 5/8	57 3/8	25 1/2	8	3/4	1/2	154
RG250L6N	51 9/16	24	3 or 4	40 11/16	13	48 1/16	48 13/16	27 1/2	8	3/4	1/2	170
RG250S6N*	60 1/8	22	4	49 15/16	13	56 5/8	57 3/8	25 1/2	8	3/4	1/2	167

Model Number	A Floor to Exhaust Conn. mm.	B Jacket Dia. mm.	C Vent Size mm.	D Floor to T&P Conn. mm.	E Floor to Gas Conn. mm.	F Floor to Top of Heater mm.	G Floor to Water Conn. mm.	H Depth mm.	J C/L of Water Conn. mm.	M Water Conn. NPT mm.	S Gas Conn. Size mm.	Approx. Shipping Weight kg.
RG130T6N*	1518	406	76 or 102	1264	330	1429	1448	495	203	19	13	48
RG230T6N*	1518	457	76 or 102	1264	330	1429	1448	546	203	19	13	53
RG230S6N	1251	508	76 or 102	987	330	1162	1181	597	203	19	13	51
RG140T6N*	1557	457	76 or 102	1311	330	1468	1513	546	203	19	13	60
RG240T6N*	1527	508	76 or 102	1264	330	1438	1457	597	203	19	13	61
RG240S6N*	1310	559	76 or 102	1043	330	1221	1240	648	203	19	13	63
RG150T6N*	1527	508	76 or 102	1268	330	1438	1457	597	203	19	13	67
RG250T6N*	1527	559	76 or 102	1268	330	1438	1457	648	203	19	13	70
RG250L6N	1310	610	76 or 102	1033	330	1221	1240	699	203	19	13	77
RG250S6N*	1527	559	102	1268	330	1438	1457	648	203	19	13	76

Propane models feature a Titanium Stainless Steel propane burner. For Propane (LP) models change suffix "N" to "X".

For 10 year models, change suffix from "6" to "10".

* Based on manufacturer's rated recovery efficiency.

• Models feature optional top T&P location and must be specified when ordering.

Note: RG230S6N and RG250L6N do not have top T&P option.

Uniform Energy Factor and First Hour Rating is based on the latest AHRI directory listings.

GENERAL:

Meets IECA Requirements. All gas water heaters are certified at 300 PSI test pressure (2068 kPa) and 150 PSI working pressure (1034 kPa). All water connections are 3/4" NPT (19mm) on 8" (203mm) centers. All gas connections are 1/2" (13mm). All models design-certified by CSA International to ANSI standard Z21.10.1.

Dimensions and specifications subject to change without notice in accordance with our policy of continuous product improvement.

Suitable for Water (Potable) Heating and Space Heating. Toxic chemicals, such as those used for boiler treatment, shall NEVER be introduced into this system. This unit may NEVER be connected to any existing heating system or component(s) previously used with a non-potable water heating appliance.

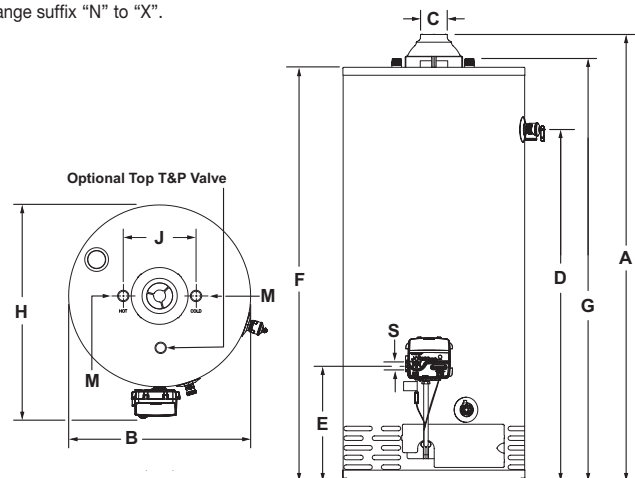

Sales: 800-523-2931

24/7 Technical Support: 800-334-3393 • Email: TechServ@bradfordwhite.com

Products made by Bradford White are manufactured in America using the finest materials and components from around the world. ©2025, Bradford White Corporation, USA. All rights reserved.



1101-1125