

TABLE OF CONTENTS:

- Specifications
- Parts List
- Assembly Instructions
- Maintenance
- Safety
- Limited Warranty



Specifications:

Part No.	Dimension	Capacity	Net Weight
TMC8080	31" W x 20" D x 43" H (800 x 500 x 1,100 mm)	220 LBS (100 kg)	79 LBS (36 kg)

- » Carefully unpack all parts and components and compare to the Parts List inventory below. Read all assembly instructions before beginning to assemble your BuildPro Tool Cart. During assembly, do not tighten bolts until all components are properly aligned, then tighten fully.

No.	Item	Qty	No.	Item	Qty
A	Tool Organizer Plate	1	L1	Casters (swiveling)	2
B	Tool Shelf (top)	1	L2	Casters (fixed)	2
C	Tool Shelf (bottom)	1	N	Sleeves	21
D	Rear Leg Assembly (left)	1	P	Magnetic Tool Bar	2
E	Rear Leg Assembly (right)	1	Q1	Round Head Bolt M8 x 60	21
F	Bridge Channel	1	Q2	Hex Head Bolt M6 x 16	22
G	Rear Slotted Cross Bar	1	Q3	Flush Shoulder Screw M6 x 20	24
H	Pull / Push Handle	1	R1	Hex Nut 8 mm	21
J1	Rubber Pad 795 x 345 x 1.5 mm	1	R2	Hex Nut 6 mm	32
J2	Rubber Pad 795 x 495 x 1.5 mm	1	S	Washer 6 mm	34
K	Pegboard Panel	1			

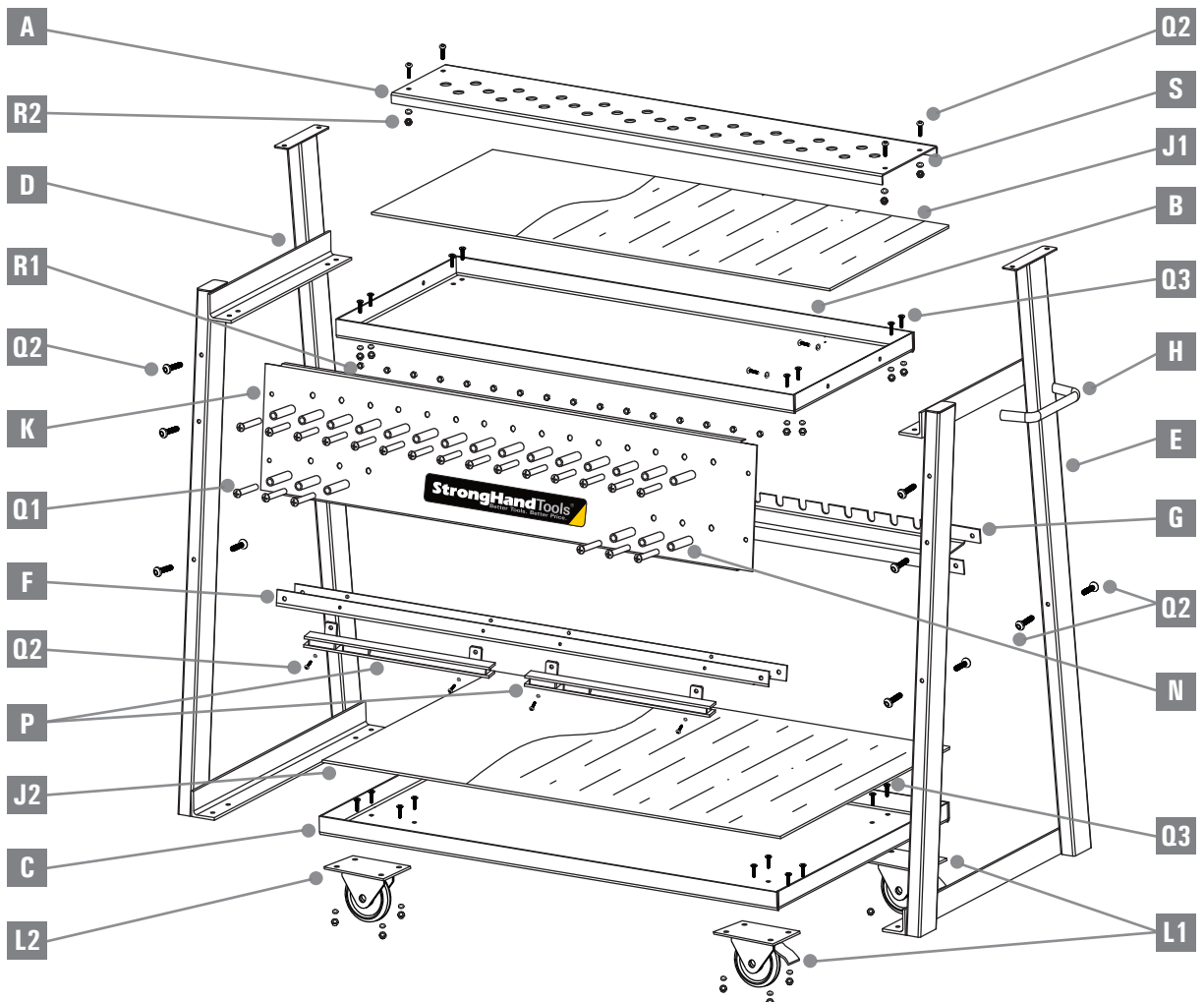

» Tools required for assembly : wrenches, phillips screwdriver and pliers.

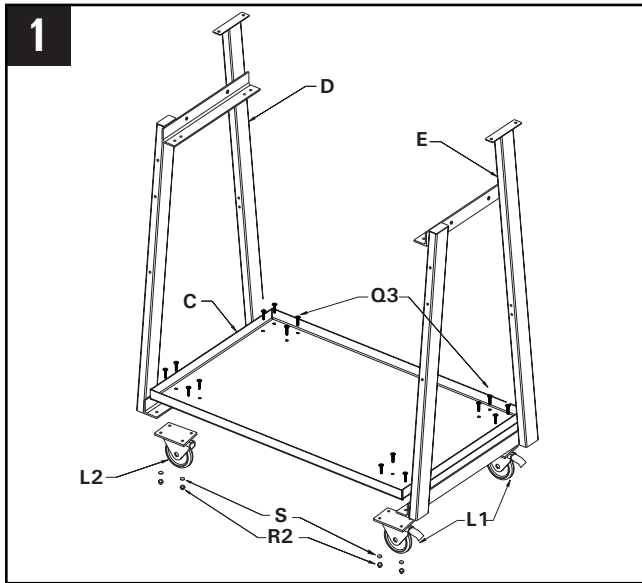

Assemble the Tool Cart frame by attaching the vertical and horizontal support assemblies (**D**, **E**) to the bottom shelf (**C**) using Flush Shoulder Screws and Washers (**Q3**, **S**).
Install Casters (**L1**, **L2**) using Hex Nuts (**R2**).

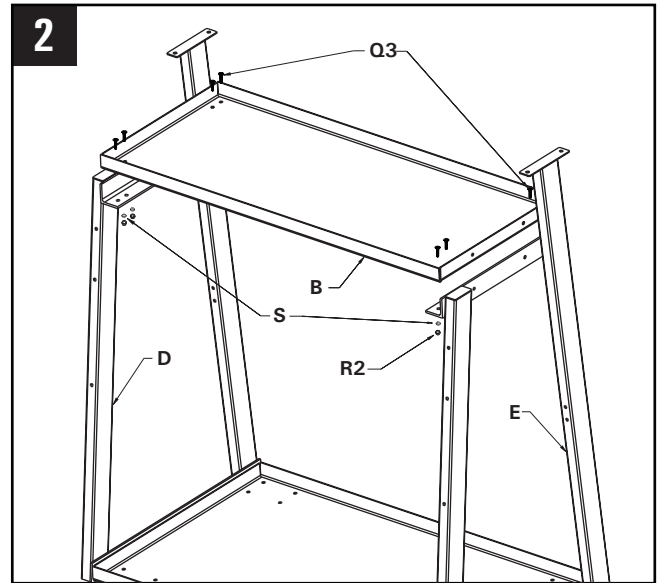

Attach the top shelf (**B**) to the frame assembly using Flush Shoulder Screws (**Q3**) Hex Nuts (**R2**) and Washers (**S**).

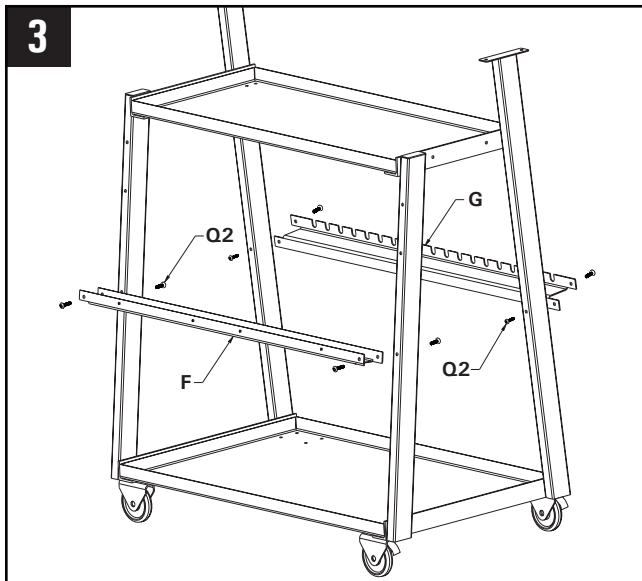

Attach the Bridge Channel (**F**) to the front vertical support bars using Hex Head Bolts and Washers (**Q2**, **S**). Attach the Rear Slotted Cross Bar (**G**) to the rear vertical support bars using Hex Head Bolts and Washers (**Q2**, **S**).

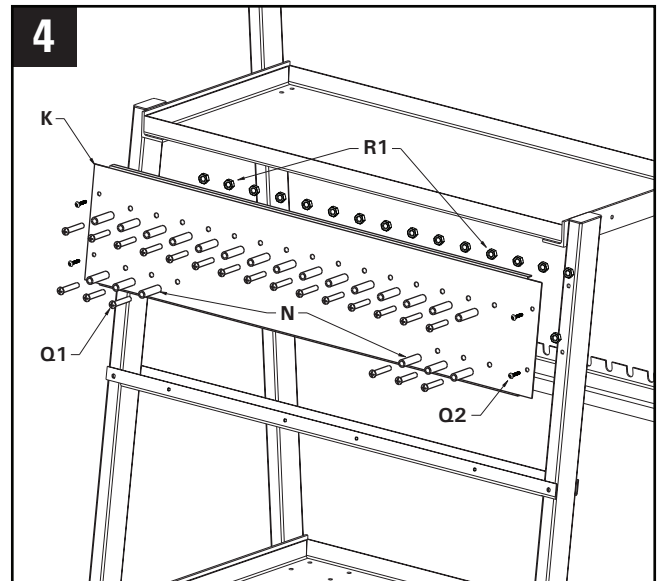

Install the Pegboard Panel (**K**) on the front vertical support bars using Hex Head Bolts (**Q2**). Prepare Pegs for installation onto the Pegboard Panel; Place 21 pcs. of Sleeves (**N**) over 21 pcs. of Round Head Bolts (**Q1**). Insert into holes on Pegboard Panel, and fasten to Panel with Hex Nuts (**R1**).

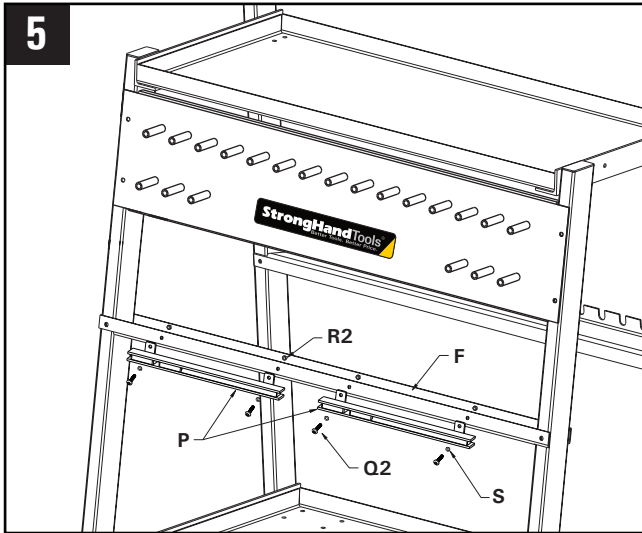

Attach Magnetic Tool Bars (*P*) to the Bridge Channel (*F*) using Hex Head Bolts (*Q2*), Hex Nuts (*R2*) and Washers (*S*).

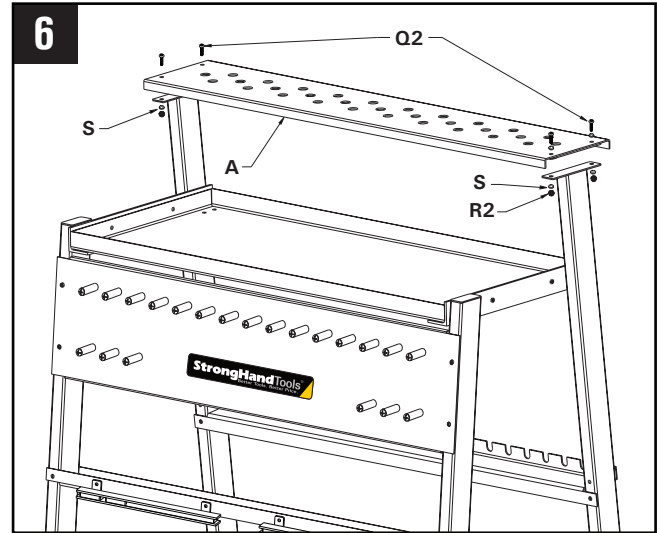

Install the top Tool Organizer Plate (*A*) using Hex Head Bolts (*Q2*), Nuts (*R2*) and Washers (*S*).

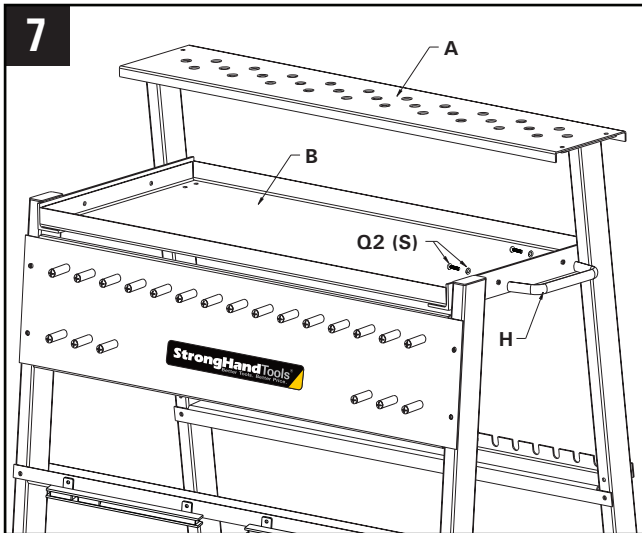

Install Pull Handles (*H*) on the side of the Top Shelf (*B*) using Hex Head Bolts and Washers (*Q2*, *S*).



Tighten all Hex Head Bolts. No-mar Rubber Pads (*J1*, *J2*) may be used to protect the surface of top and bottom shelves.

Maintenance

Keep the cart clean for optimal performance. Wipe away dust and debris from the shelves and legs.

Safety

ALWAYS wear safety goggles, gloves, and other appropriate safety items for protection. Use the cart only for its intended purpose. NEVER stand on the cart. Do not drop the cart, throw it, or otherwise misuse the cart.

Warranty

Strong Hand Tools® products are warranted to be free from defects in material and workmanship. Return the tool to the place of purchase for a replacement if warranty applies.