



United Technologies
turn to the experts

Carrier Sensors Installation Guide





Verify that you have the most current version of this document from www.hvacpartners.com or your local Carrier office.

Important changes are listed in **Document revision history** at the end of this document.

CARRIER CORPORATION ©2016. All rights reserved throughout the world. i-Vu is a registered trademark of Carrier Corporation. BACnet is a registered trademark of ASHRAE. All other trademarks are the property of their respective owners.

Contents

Introduction to Carrier sensors	1
ZS sensors	3
Specifications	5
CO2 sensor installation.....	6
Rnet Configuration	6
Rnet wiring specifications	6
To address a ZS Sensor	7
Power requirements.....	8
To wire and mount a ZS Sensor	9
To communicate through the local access port.....	10
Troubleshooting	11
SPT sensors	13
SPT sensor specifications.....	15
Rnet Configuration	15
To address an SPT Standard sensor.....	15
Rnet wiring specifications	16
Mounting location.....	16
To wire and mount the SPT sensor	16
Using an SPT sensor.....	18
To change sensor properties.....	19
To communicate through the local access port.....	20
Troubleshooting SPT sensors.....	20
Alternate space temperature sensor	22
Sensor specifications	23
Wiring specifications.....	24
Mounting location.....	24
To wire and mount the sensor	25
To change a T59 sensor's options.....	25
Supply Air Temperature sensor	28
SAT sensor specifications.....	28
Wiring specifications.....	29
Mounting location.....	30
To wire and mount the SAT sensor	30
Duct Air Temperature sensor	31
DAT sensor specifications	31
Wiring specifications.....	32
Mounting location.....	32
To wire and mount the DAT sensor.....	33
Outdoor Air Temperature sensor	34
OAT sensor specifications	34
Wiring specifications.....	35
Mounting location.....	35
To wire and mount the OAT sensor.....	36
Primary Air Temperature sensor	37
PAT sensor specifications.....	37
Wiring specifications.....	38
Mounting location.....	38
To wire and mount the PAT sensor	39

CO2 sensor	40
CO2 sensor specifications	41
Wiring specifications	41
Mounting location	42
To wire and wall-mount the CO2 sensor	42
To wire and duct-mount the sensor	43
CO2/Temperature sensor	44
CO2/Temperature sensor specifications	45
Wiring specifications	46
Mounting location	46
To wire and mount the CO2/Temperature sensor	46
Relative Humidity sensors	48
Sensor specifications	49
Wiring specifications	50
Mounting location	50
To wire and mount the Space RH sensors	51
Typical power wiring diagrams for Space RH sensors	53
To wire and mount the Duct RH sensor	54
To wire and mount the Outdoor RH sensor	55
Typical power wiring diagrams for Duct RH and Outdoor RH sensors	56
Calibrating and troubleshooting relative humidity sensors	57
Enthalpy switch/receiver and Enthalpy sensor	59
Enthalpy switch/sensor specifications	60
Wiring specifications	60
Mounting location	60
To wire and mount the switch/sensor	61
Appendix: I-Vu® Control System Wiring Specifications and Recommended Vendors	63
Document revision history	64
Index	65





Introduction to Carrier sensors

The following Carrier sensors can be used with the specified Open controllers. For information on Carrier PIC controllers, please see the controller's *Installation Guide*.

Sensor	Part number	Controller											
		WV Zone	WV Bypass	RTU Open	ChillerVu™	UC Open	UC Open XP	MPC Open XP	AppController	VAV Zone	UPC Open		
Space temperature sensor (page 13)	ZS* ZSPL* ZSP* ZSPF*	•		•	•	•	•	•	•	•	•		
	SPS SPPL SPP SPPF	•		•	•	•	•	•	•	•	•	•	•
Alternate space temperature sensor (page 22)	33ZCT55SPT 33ZCT56SPT 33ZCT59SPT	•		•		•	•			•	•		
Supply Air Temperature sensor (page 28)	33ZCSENSAT	•	•	•		•	•			•	•		
Duct Air Temperature sensor (page 31)	33ZCSENDAT	•	•	•		•	•			•			
Outdoor Air Temperature sensor (page 34)	33ZCSENOAT			•		•	•			•			
Primary Air Temperature sensor (page 37)	33ZCSENPAT					•	•				•		
CO ₂ sensor (page 40)	33ZCSPTCO2-01, 33ZCSPTCO2LCD-01	•		•		•	•			•	•		
CO ₂ /Temperature sensor (page 44) **	33ZCT55CO2 33ZCT56CO2	•		•		•	•			•	•		
Wall Relative Humidity sensor (page 48)	33ZCSENSRH-02	•		•		•	•			•	•		
Duct Relative Humidity sensor (page 48)	33ZCSENDRH-02			•		•	•			•			
Outdoor Relative Humidity sensor (page 48)	33ZCSENRH-02			•		•	•			•			
Enthalpy switch/receiver (page 59) Enthalpy sensor (page 59)	33CSENTHSW 3CSENSEN			•		•	•			•			

* ZS Sensors are thermistor-based temperature sensors that may optionally sense humidity, CO₂, or VOC.

 **WARNING** Disconnect electrical power to the controller or sensor before wiring it. Failure to follow this warning could cause electrical shock, personal injury, or damage to the device.

 **CAUTION** Do not run sensor or relay wires in the same conduit or raceway with Class 1 AC or DC service wiring.









- Do not abrade, cut, or nick the outer jacket of the cable.
- Do not pull or draw cable with a force that may harm the physical or electrical properties.
- Avoid splices in any control wiring.

ZS sensors

ZS Sensors are thermistor-based temperature sensors that may optionally sense humidity, CO₂, or VOC. ZS Sensors are wired to the Rnet on i-Vu® Open controllers:

The following table shows the 4 ZS Sensor models and their features.

Part # with Carrier logo	Part # without logo	Sensor	Features
ZS-CAR	ZS-BNK	 <p>ZS Standard</p>	<ul style="list-style-type: none"> Local access port No user control
ZS-C-CAR	ZS-C-BNK		
ZS-H-CAR	ZS-H-BNK		
ZS-V-CAR	ZS-V-BNK		
ZS-HC-CAR	ZS-HC-BNK		
ZS-HV-CAR	ZS-HV-BNK		
ZSPL-CAR	ZSPL-BNK		
ZSPL-C-CAR	ZSPL-C-BNK		
ZSPL-H-CAR	ZSPL-H-BNK		
ZSPL-V-CAR	ZSPL-V-BNK		
ZSPL-HC-CAR	ZSPL-HC-BNK		
ZSPL-HV-CAR	ZSPL-HV-BNK		

Part # with Carrier logo	Part # without logo	Sensor	Features
ZSP-CAR	ZSP-BNK	ZS Pro 	<ul style="list-style-type: none"> • LCD display •  button to override the schedule and put the zone in an occupied state, or force the zone to an unoccupied state •  and  buttons to change any editable property, such as the setpoint temperature •  button to cycle through information defined in the control program • Green LED to indicate occupied state • Local access port
ZSP-C-CAR	ZSP-C-BNK		
ZSP-H-CAR	ZSP-H-BNK		
ZSP-V-CAR	ZSP-V-BNK		
ZSP-HC-CAR	ZSP-HC-BNK		
ZSP-HV-CAR	ZSP-HV-BNK		
ZSPF-CAR	ZSPF-BNK	ZS Pro-F 	All of the ZS Pro's features plus: <ul style="list-style-type: none"> •  button to turn on heating, cooling, or fan only, or set to auto control. •  button to adjust fan speed • F/C button to set temperatures to Fahrenheit or Celsius
ZSPF-C-CAR	ZSPF-C-BNK		
ZSPF-H-CAR	ZSPF-H-BNK		
ZSPF-V-CAR	ZSPF-V-BNK		
ZSPF-HC-CAR	ZSPF-HC-BNK		
ZSPF-HV-CAR	ZSPF-HV-BNK		

To configure the control program for the desired user interaction with the sensor, see the *ZS Sensor Application Guide*.

For basic user instructions, see the *ZS Sensor User Guide*.

Specifications

Sensing element accuracy	
Temperature	<p>Temperature only: 32° to 122°F (0° to 50°C): ±0.36°F (0.2°C)</p> <p>Temperature if humidity is included: 50° to 104°F (10° to 40°C): ±0.54°F (0.3°C)</p>
Humidity	10% to 90%: ±1.8% typical. Less than 0.5% drift per year.
CO ₂	<p>400 to 1250 PPM: ±30 PPM or 3% of reading, whichever is greater 1250 to 2000 PPM: ±5% of reading plus 30 PPM</p> <p>See <i>CO₂ sensor installation</i> (page 6).</p>
VOC	0 to 2,000 CO ₂ PPM Equivalent: ±100PPM
Power requirements	<p>Temperature only ZS Standard or ZS Plus: 12 Vdc @ 6 mA ZS Pro or Pro-F: 12 Vdc @ 7 mA</p>
	<p>Temperature with humidity ZS Standard or ZS Plus: 12 Vdc @ 7 mA ZS Pro or Pro-F: 12 Vdc @ 8 mA</p>
	<p>Temperature with humidity and VOC - All models 12 Vdc @ 60 mA</p>
	<p>Temperature with humidity and CO₂ - All models 12 Vdc @ 15 mA (idle) to 190 mA (CO₂ measurement cycle)</p>
	<p>Temperature and CO₂ - All models 12 Vdc @ 14 mA (idle) to 189 mA (CO₂ measurement cycle)</p>
Power supply	The 4-conductor Rnet cable from a controller supplies +12 Vdc @ 210 mA. For additional power, use an external power supply. Use the above power requirements to calculate the size of the external power supply. The controller and the external power supply must share a common ground.
Communication	115 kbps
Local access port	For local access to start up and troubleshoot the system
Environmental operating range	32 to 122°F (0 to 50°C), 10 to 90% relative humidity, non-condensing
Mounting	Standard 4x2-in. electrical box using the 6-32 x 1/2" mounting screws provided
Overall dimensions	<p>Temperature sensor or temperature with humidity sensor</p> <p>Width: 3 in. (7.62 cm) Height: 4-13/16 in. (12.22 cm) Depth: 13/16 in. (2.01 cm)</p>
	<p>Sensor with CO₂ or VOC</p> <p>Width: 2-7/8 in. (7.3 cm) Height: 4-13/16 in. (12.22 cm) Depth: 1-1/4 in. (3.18 cm)</p>
Listed by	FCC Part 15-Subpart B-Class A, CE

CO2 sensor installation

 **IMPORTANT** Do not install ZS CO₂ sensors in continuous occupancy applications. For a ZS CO₂ sensor to maintain accuracy, it must be installed only in a zone that is unoccupied for at least 4 hours a day with enough air movement during the unoccupied period to return CO₂ to background levels.

A ZS Sensor with CO₂ uses Automatic Background Calibration which waits for the lowest value in a 24-hour period that deviates no more than 40PPM for at least 15 minutes, and assigns that value to the 400PPM baseline. This daily Automatic Background Calibration may take up to 21 days to fully calibrate the sensor.

NOTE Dropping a sensor can upset the calibration, and it may require 21 days to return to our stated accuracy.

Rnet Configuration

An Rnet can consist of the following devices wired in a daisy-chain or star configuration:

- Up to 15 ZS Sensors
 - NOTE** You cannot have more than 5 sensors per control program
- Up to 5 ZS sensors and 1 Equipment Touch device

NOTE You cannot have SPT sensors and ZS sensors on the same Rnet.

Rnet wiring specifications

NOTE Use the specified type of wire and cable for maximum signal integrity.

Description	4 conductor, shielded or unshielded, CMP, plenum rated cable
Conductor	22 AWG (7x0096) bare copper
Maximum length	500 feet (152 meters)
Insulation	Low-smoke PVC (or equivalent)
Color Code	Black, white, green, red
Shielding	If shielded, Aluminum/Mylar shield (100% coverage) with TC drain wire
UL temperature rating	32–167 °F (0–75 °C)
Voltage	300 Vac, power limited
Listing	UL: NEC CL2P, or better

To address a ZS Sensor

Each ZS Sensor on an Rnet must have a unique address, but addresses do not have to be sequential.

Use the DIP switches on the back of the ZS Sensor to set an address from 0 to 14. (1 is factory default.) Each DIP switch has the value shown in the figure below. Turn on as many DIP switches as you need so that their total value equals the address.

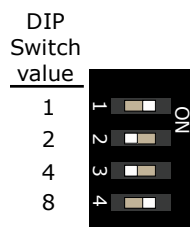

EXAMPLE DIP switches 1 and 4 above are on. Their values (1 + 8) total 9, so the sensor's address is 9.

Power requirements

See *Specifications* (page 5) for power requirements and power supply information.

Sample wiring diagram with external power supply:

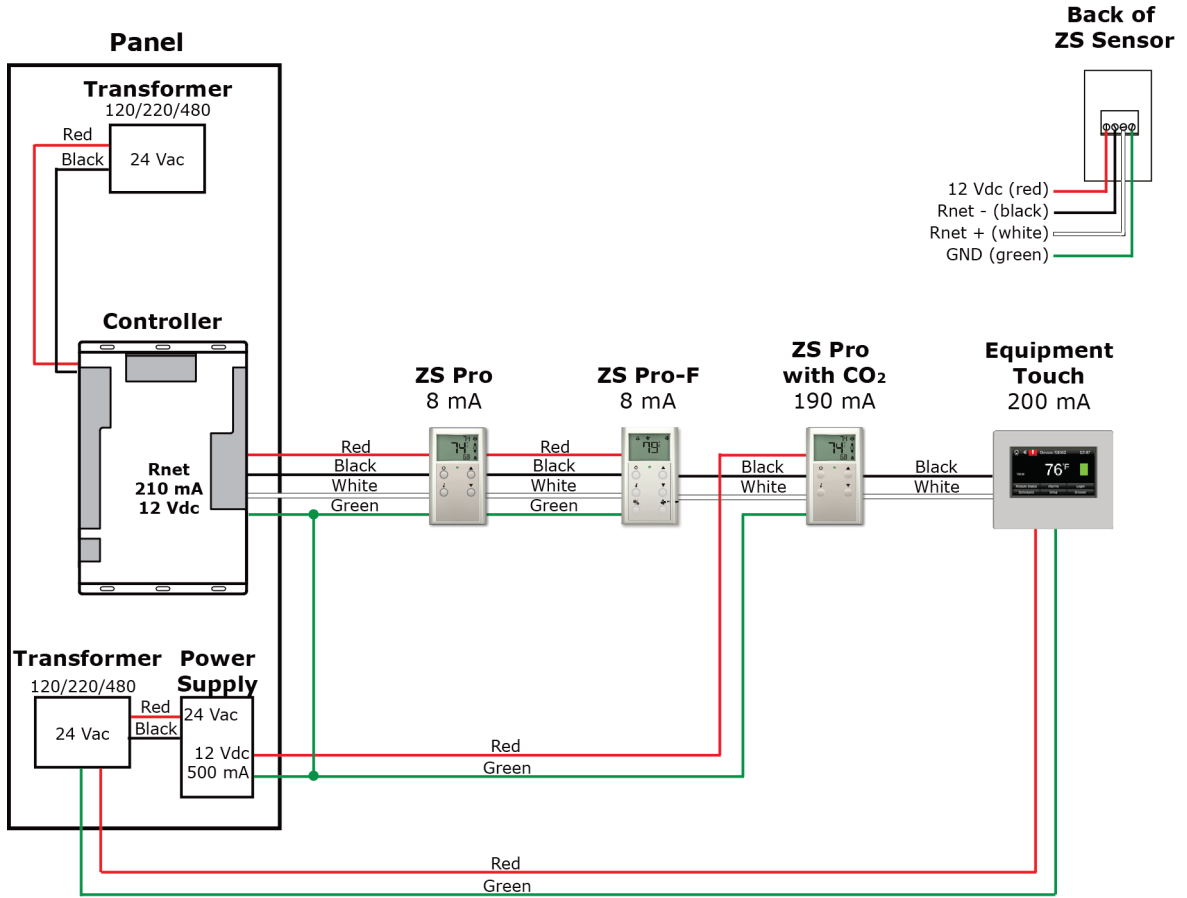

CAUTION Do not share power between controller's power and external 12 Vdc unless both devices are half wave.

To wire and mount a ZS Sensor

PREREQUISITE The Rnet cable is wired to the controller. The shield wire and the ground wire should be inserted into the controller's GND terminal.

- 1 Turn off the controller's power.
- 2 Pull the backplate off the ZS Sensor. You may need to turn the setscrews in the bottom of the sensor clockwise until you can remove the backplate.
- 3 Pull the Rnet communication cable through the slit in the insulated backing material.

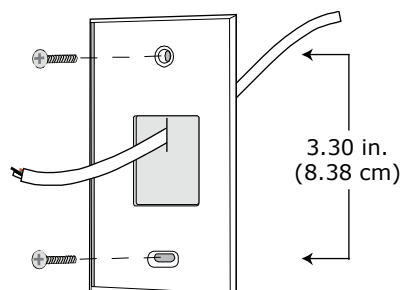

- 4 Use 2 screws to mount the backplate to the wall or outlet box.
Partially cut, then bend and pull off the outer jacket of the Rnet cable(s). Do not nick the inner insulation.

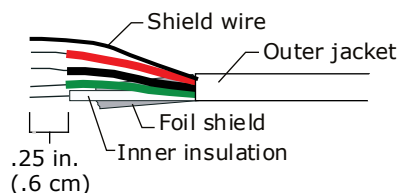

- 5 Strip about .25 inch (.6 cm) of the inner insulation from each wire.
- 6 If wiring 1 cable to the ZS Sensor, cut the shield wire off at the outer jacket, then wrap the cable with tape at the outer jacket to cover the end of the shield wire.

If wiring 2 cables in a daisy-chain configuration, twist together the shield wires, then wrap the shield wires with tape.
- 7 Insert the other 4 wires into the ZS Sensor's screw terminal connector. If wiring 2 cables, insert like-colored wires into each terminal.

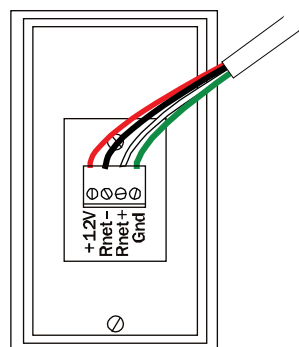

Carrier recommends that you use the following Rnet wiring scheme:

Connect this wire...	To this terminal...
Red	+12V
Black	Rnet-
White	Rnet+
Green	Gnd

CAUTION Allow no more than 0.06 inch (1.5 mm) bare communication wire to protrude. If bare communication wire contacts the cable's foil shield, shield wire, or a metal surface other than the terminal block, the device may not communicate correctly.

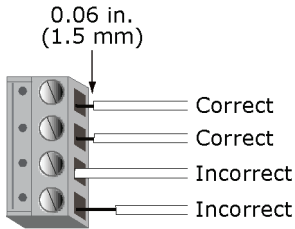

- 8 Attach the sensor's cover and circuit board to the mounted backplate, inserting the top first.
- 9 Turn the setscrews one full turn counterclockwise so that the cover cannot be removed.
- 10 Turn on the controller's power.

NOTE Use the same polarity throughout the Rnet.

To communicate through the local access port

You can connect to the Local Access port of the ZS Sensor to perform test and balance or to make changes to any device on the network.

PREREQUISITES

- A computer with a USB port
- A USB Link (Part #USB-L)

CAUTION If multiple controllers share power but polarity was not maintained when they were wired, the difference between the controller's ground and the computer's AC power ground could damage the USB Link and the controller. If you are not sure of the wiring polarity, use a USB isolator between the computer and the USB Link. Purchase a USB isolator online from a third-party manufacturer.

Connect the USB Link to the computer and to the ZS Sensor's local access port.

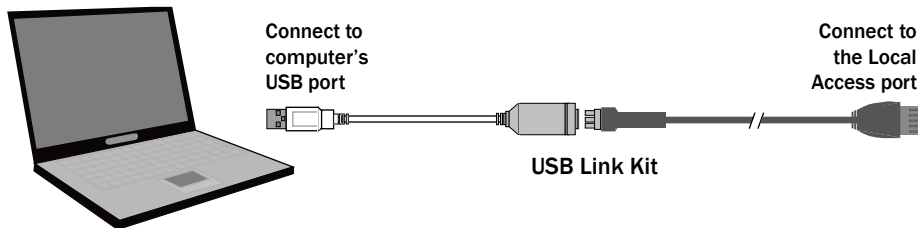

NOTE If using a USB isolator, plug the isolator into your computer's USB port, and then plug the USB Link cable into the isolator.

Troubleshooting

ZS Pro or ZS Pro-F

If display shows...	Then...
Incorrect or missing values	<p>Check for errors in the i-Vu® application and Snap.</p> <p>On the control program's Properties page, select the Rnet Points tab. Verify that values coming in from the sensors and those going out to the sensors are expected values.</p> <p>In the i-Vu® application, double-click the Sensor Binder and ASVI microblocks to check for problems in the Status and/or Error columns.</p>

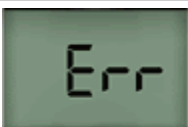

If the **Error** column shows **Resource Allocation**, try formatting the sensor. If the error is not corrected by formatting, the control program engineer should reduce the number of items that the sensor is trying to display.

Nothing	The sensor has no power.
	<p>The sensor is not communicating with the network. Check:</p> <ul style="list-style-type: none"> • Software/addressing setup • Wiring connections • Controller operating status

Characters that
seem out
of place

The sensor may have a memory problem. Try formatting the sensor.

To format a ZS Sensor

Formatting a sensor clears its flash memory. Do either of the following to format a sensor:

- Download the controller that the sensor is connected to.
- Do the following:
 - a) Remove the wiring connector from the sensor.
 - b) Note the current position of the DIP switches.
 - c) Set all DIP switches to the ON position.
 - d) Reattach the wiring connector to format.
 - e) After approximately 3 seconds, remove the wiring connector.
 - f) Set the DIP switches back to their original position.
 - g) Reattach the wiring connector.

NOTE If you move a sensor from one controller to another controller that has a different control program, format the sensor.

SPT sensors

Part #SPS, SPPL, SPP, SPPF

An SPT sensor is a thermistor-based, wall-mounted temperature sensor that monitors zone temperature. An SPT sensor is wired to a controller's **Rnet** port.

Carrier offers the following SPT sensors:

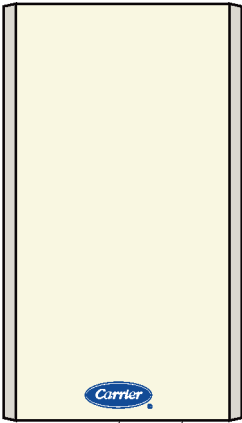
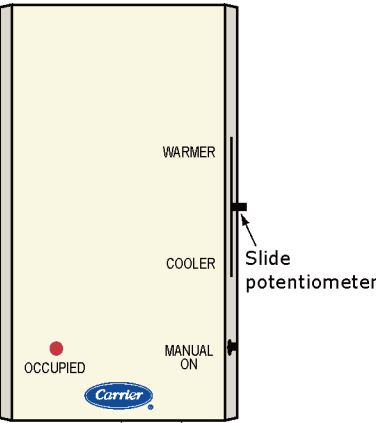
Sensor	Features
<p>SPT Standard Part #SPS</p> 	<ul style="list-style-type: none"> • Local access port • No operator control
<p>SPT Plus Part #SPPL</p> 	<ul style="list-style-type: none"> • Slide potentiometer to adjust setpoint • MANUAL ON button to override schedule • LED to show occupied status • Local access port

Sensor	Features
<p>SPT Pro Part #SPP</p>	<ul style="list-style-type: none"> • LCD display • MANUAL ON button to override schedule • WARMER and COOLER buttons to adjust setpoint • INFO button to cycle through zone and outside air temperatures, setpoints, and local override time • Local access port
<p>SPT Pro Plus Part #SPPF</p>	<ul style="list-style-type: none"> • LCD display • MANUAL ON button to override schedule • WARMER and COOLER buttons to adjust setpoint • INFO button to cycle through zone and outside air temperatures, setpoints, and local override time • FAN SPEED button to adjust fan speed • Local access port

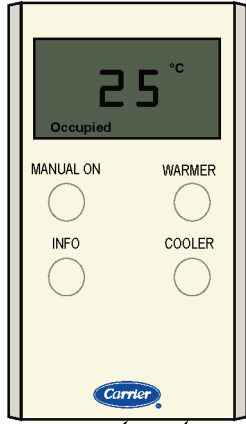

Setscrew
Local access port



Setscrew
Local access port

SPT sensor specifications

Sensor	Thermistor. Accuracy $\pm 0.45^{\circ}\text{F}$ (0.25°C). Less than $\pm 0.18^{\circ}\text{F}$ (0.1°C) drift over a 10 year period.	
Sensor range	50°F to 95°F (10°C to 35°C)	
Power	Supplied by the 4-conductor cable (+12 Vdc @ 210 mA) from the controller.	
Communication	115 kbps	
Local access port	For local access to start up and troubleshoot system	
Environmental operating range	32–122°F (0–50°C), 10–90% relative humidity, non-condensing	
Mounting	Standard 4x2-in. electrical box using provided 6-32 by 1/2 in. mounting screws.	
Overall dimensions:	Width:	2-3/4 in. (6.9 cm)
	Height:	4-3/4 in. (12.1 cm)
	Depth:	5/8 in. (1.6 cm)

Rnet Configuration

You wire SPT sensors to a controller's **Rnet** port. An Rnet can consist of any of the following combinations of devices wired in a daisy-chain or hybrid configuration:

- 1 SPT Plus, SPT Pro, or SPT Pro Plus
- 1–4 SPT Standards
- 1–4 SPT Standards, and 1 SPT Plus SPT Pro, or SPT Pro Plus
- Any of the above combinations, plus up to 2 BACview®'s but no more than 6 devices total

NOTE You must set addresses only on the following Rnet devices:

- SPT Standard sensors if you have more than one on the Rnet. See *To address an SPT Standard sensor* (page 15).
- BACview®'s if you have two on the Rnet. See the *BACview® Installation and User Guide*.

To address an SPT Standard sensor

If the Rnet has multiple SPT Standard sensors, the first sensor retains its default address of 1. You must give each additional SPT Standard a unique address on the Rnet. To set the address:

- 1 Pull the back plate off the sensor, pulling from the bottom first.
- 2 Remove the two hexagonal screws that attach the circuit board to the cover plate.
- 3 Remove the cover plate.
- 4 On the circuit board, set the address jumper to 2, 3, or 4.
- 5 Attach the circuit board to the cover plate with the hexagonal screws.

Rnet wiring specifications

NOTE Use the specified type of wire and cable for maximum signal integrity.

Description	4 conductor, unshielded, CMP, plenum rated cable
Conductor	18 AWG
Maximum length	500 feet (152 meters)
Recommended coloring	Jacket: White Wiring: Black, white, green, red
UL temperature rating	32–167 °F (0–75 °C)
Voltage	300 Vac, power limited
Listing	UL: NEC CL2P, or better

Mounting location

Mount the sensor:

- In an area representing the average temperature in the space
- On an interior wall
- Approximately 5 feet (1.5 meters) from the floor, or as required by local code
- At least 4 feet (1.2 meters) from any corner
- At least 2 feet (.6 meter) from an open doorway

Do not mount the sensor:

- In drafty locations such as near air conditioning or heating ducts, or near open windows
- Over heat sources such as baseboard heaters, radiators, directly above wall-mounted lighting dimmers, or in direct sunlight

NOTE The sensor mounting plate accommodates the NEMA standard 2x4 in. standard single gang electrical box. However, the sensor can be mounted directly on the wall surface if local codes permit.

To wire and mount the SPT sensor

NOTE The sensor mounting plate accommodates the NEMA standard 2x4 in. standard single gang electrical box. However, the sensor can be mounted directly on the wall surface if local codes permit.

- 1 Remove the mounting plate from the SPT sensor. You may need to turn the setscrew in the bottom of the sensor clockwise until you can remove the mounting plate.

- 2 Pull the Rnet communication cable through the wire guide in the mounting plate.

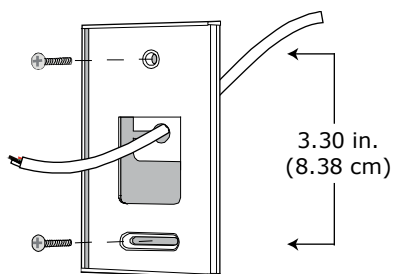

- 3 Use the 2 mounting screws provided to attach the mounting plate to the wall or electrical box.
- 4 Partially cut, then bend and pull off the outer jacket of the Rnet cable(s). Do not nick the inner insulation. Strip about .25 inch (.6 cm) of the inner insulation from each wire.

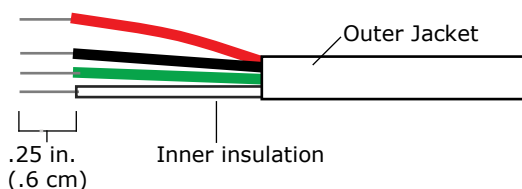

- 5 Insert the other 4 wires into the sensor's screw terminal connector. If wiring 2 cables, insert like-colored wires into each terminal.

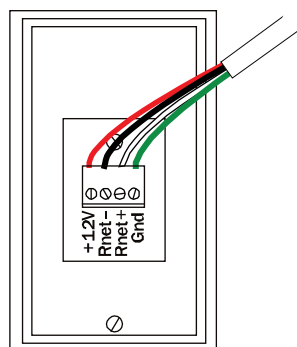

Carrier recommends that you use the following Rnet wiring scheme:

Connect this wire...	To this terminal...
Red	+12V
Black	Rnet-
White	Rnet+
Green	Gnd

CAUTION Allow no more than .06 inch (1.5 mm) bare communication wire to protrude. If bare communication wire contacts a metal surface other than the terminal block, the sensor may not communicate correctly.

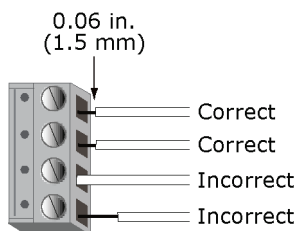

- 6 Attach the sensor's cover and circuit board to the mounting plate, inserting the top first.
- 7 Turn the setscrew one full turn counterclockwise to secure the cover to the mounting plate.
- 8 Wire the sensor to the Open controller. See the controller's *Installation and Startup Guide* for details.

Using an SPT sensor

All SPT sensors

Feature	Usage
Local Access port	See <i>To communicate through the Local Access port</i> (page 10).

SPT Plus

Feature	Usage
Slide potentiometer	Move the potentiometer to raise or lower the zone's setpoint. The maximum you can adjust the setpoint is defined in the Max Adjust field*.
MANUAL ON button	<p>Press this button one time to override the schedule and set the zone to occupied for the amount of time defined in the Each pulse field*. Press the button again to incrementally increase the time. For example, if the Each pulse field is set at five minutes, press the button once for an occupancy of five minutes, twice for ten minutes, and so on. The maximum length of time you can override the schedule is defined in the Max Accum field*.</p> <p>To cancel the override, hold down the MANUAL ON button until the OCCUPIED LED turns off.</p>
OCCUPIED LED	The LED lights when the zone is occupied from a regular schedule or a manual override.

SPT Pro

Feature	Usage
Display	<p>The display shows occupancy, zone temperature, and an alarm bell icon. Celsius values are to the nearest 0.5 degree; Fahrenheit values are to the nearest full degree.</p> <p>The display shows Occupied when the zone is occupied from a regular schedule or from a manual override.</p>
MANUAL ON button	<p>Press one time to override the schedule and set the zone to occupied for the amount of time defined in the Each pulse field*. Press button again to incrementally increase the time. For example, if the Each pulse field is set at five minutes, press the button once for an occupancy of five minutes, twice for ten minutes, and so on. The maximum length of time you can override the schedule is defined in the Max Accum field*.</p> <p>The display shows the duration of the override in minutes. If the override time exceeds 199 minutes, the display shows the time in hours.</p> <p>To cancel the override, hold the button down until 0 displays. Wait five seconds for the display to show the current zone temperature again.</p>

Feature	Usage
WARMER and COOLER buttons	<p>To raise or lower the zone's setpoint:</p> <ol style="list-style-type: none"> 1 Press either button to display the current average setpoint (the average between the heating and cooling setpoints). 2 Press either button again to raise or lower the setpoint. You can adjust the setpoint by no more than the amount defined in the Max Adjust field*. <p>NOTE Pressing either button overrides an unoccupied schedule and sets the zone to occupied for the amount of time defined in the Each pulse field*.</p>
INFO button	<p>Press to cycle through the:</p> <ul style="list-style-type: none"> • zone temperature • outside air temperature, if enabled in the control program • override time, in minutes • heating setpoint • cooling setpoint

SPT Pro Plus

The SPT Pro Plus has all the features of the SPT Pro plus the additional functionality described below.

Feature	Usage
MANUAL ON button	The Timed Local Override section of the microblock dialog box determines if pressing the MANUAL ON button sets the zone to occupied for a set amount of time in the same manner as the SPT Pro or sets the zone to continuously occupied.
INFO button	This button cycles through the same information as the SPT Pro.

To change sensor properties

You can use the i-Vu® application or Field Assistant, if included with your system, to change sensor properties such as the override time or maximum setpoint adjustment. Go to **Properties** page > **I/O Points** tab > and click on your applicable sensor point, i.e. **Space Temp**, **SPT Temp Sensor**, **Zone Temp Sensor** > **Details** tab of microblock popup.

Field Assistant runs on a laptop that you connect to an SPT sensor's Local Access port.

To communicate through the local access port

You can connect to the Local Access port of the ZS Sensor to perform test and balance or to make changes to any device on the network.

PREREQUISITES

- A computer with a USB port
- A USB Link (Part #USB-L)

⚠ CAUTION If multiple controllers share power but polarity was not maintained when they were wired, the difference between the controller's ground and the computer's AC power ground could damage the USB Link and the controller. If you are not sure of the wiring polarity, use a USB isolator between the computer and the USB Link. Purchase a USB isolator online from a third-party manufacturer.

Connect the USB Link to the computer and to the ZS Sensor's local access port.

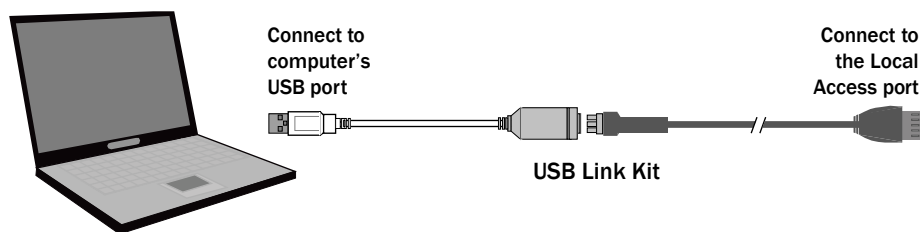

NOTE If using a USB isolator, plug the isolator into your computer's USB port, and then plug the USB Link cable into the isolator.

Troubleshooting SPT sensors

Use the following tables to troubleshoot an SPT sensor.

SPT Standard or SPT Plus

If LED on back of circuit board...	Then sensor...
Is not lit	Has no power
Blinks 1 time per second	Has power, but is not communicating
Blinks 2.5 times per second	Is correctly wired and communicating

SPT Pro or SPT Pro Plus

If display shows...	Then sensor...
Nothing	Has no power
All display elements	Has power, but is not communicating
Only the temperature and current status	Is correctly wired and communicating

NOTE If **OF** is displayed, cycle the power on the controller.

Alternate space temperature sensor

Part #33ZCT55SPT, 33ZCT56SPT, 33ZCT59SPT

The following wall-mounted space temperature sensors can be used instead of an SPT sensor to monitor zone temperature.

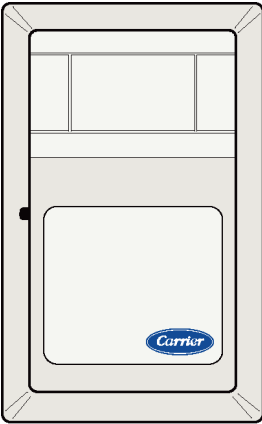
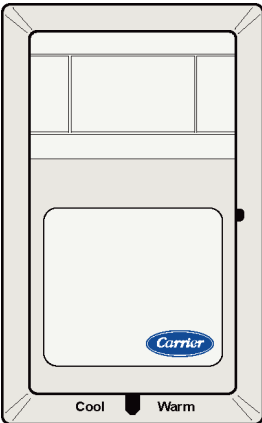
Sensor		Features
T-55 Part #33ZCT55SPT		<ul style="list-style-type: none">• Timed override button
T-56 Part #33ZCT56SPT		<ul style="list-style-type: none">• Timed override button• Setpoint adjustment

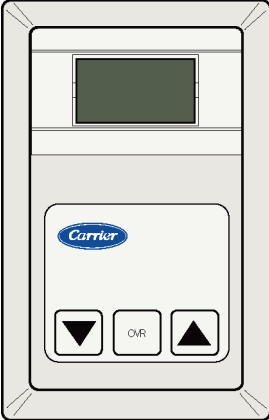
Sensor		Features
T-59 Part #33ZCT59SPT		<ul style="list-style-type: none"> • Timed override button • Setpoint adjustment • LCD display

NOTE The T-59 sensor requires a dedicated 24 Vac, 3 Va transformer to power the sensor.

Sensor specifications

Operating range	T55 and T56: 32° to 120°F (0° to 49°C) with a nominal resistance of 10,000 ohms at 77°F (25°C). See table below. T59: 40° to 104°F (5° to 40°C) with a nominal resistance of 10,000 ohms at 77°F (25°C). See table below.
Sensor tolerance	T55 and T56: ±0.2°C from 0 to 70°C T59: ±1°F from 40 to 104°C (±1°C from 4 to 40°C)
Humidity	0 to 95%, non-condensing
Power	24 Vac, 3 Va
Dimensions:	Width: 2 3/4 in. (6.98 cm) Height: 4 1/2 in. (11.46 cm) Depth: 1 1/5 in. (2.92 cm)

Thermistor Resistance vs. Temperature Values for Space Temperature Sensor

10K Type III (CP/MCI)

Temp (F)	Temp (C)	Resistance (Ohms)
-40	-40	335,651
-31	-35	242,195
-22	-30	176,683
-13	-25	130,243
-4	-20	96,974
5	-15	72,895
14	-10	55,298
23	-5	42,315
32	0	32,651
41	5	25,395
50	10	19,903
59	15	15,714
68	20	12,494
77	25	10,000
86	30	8,056
95	35	6,530
104	40	5,325
113	45	4,367
122	50	3,601
131	55	2,985
140	60	2,487
149	65	2,082
158	70	1,752

Wiring specifications

Cable from sensor to controller:	If <100 ft (30.5 meters)	22 AWG, unshielded
	If >100 ft (30.5 meters)	22 AWG, shielded
Maximum length:	500 feet (152 meters)	

Mounting location

Mount the sensor:

- In an area representing the average temperature in the space
- On an interior wall
- Approximately 5 feet (1.5 meters) from the floor, or as required by local code
- At least 4 feet (1.2 meters) from any corner
- At least 2 feet (.6 meter) from an open doorway

Do not mount the sensor:

- In drafty locations such as near air conditioning or heating ducts, or near open windows
- Over heat sources such as baseboard heaters, radiators, directly above wall-mounted lighting dimmers, or in direct sunlight

NOTE The sensor mounting plate accommodates the NEMA standard 2x4 in. standard single gang electrical box. However, the sensor can be mounted directly on the wall surface if local codes permit.

To wire and mount the sensor

- 1 Turn the 2 setscrews at the bottom of the sensor clockwise to release the sensor's cover from the mounting plate.
- 2 Lift the cover from the bottom, and then release it from the top fasteners.
- 3 Feed the wires from the electrical box through the opening in the center of the sensor mounting plate.
- 4 Use the 2 mounting screws provided to attach the mounting plate to the electrical box.
- 5 Strip the outer jacket from the cable for at least 3 inches (7.62 cm). Strip .25 inch (.6 cm) of insulation from each wire. Cut the shield and drain wire from the cable.
- 6 Use the appropriate diagram below to connect the wiring to the sensor's terminals.
- 7 Reattach the sensor's cover to the mounting plate, inserting the top first.
- 8 Turn the two Allen screws counterclockwise to secure the cover to the mounting plate.
- 9 Wire the sensor to the Open controller. See the controller's *Installation and Startup Guide* for details.

NOTE Clean sensor with damp cloth only. Do not use solvents.

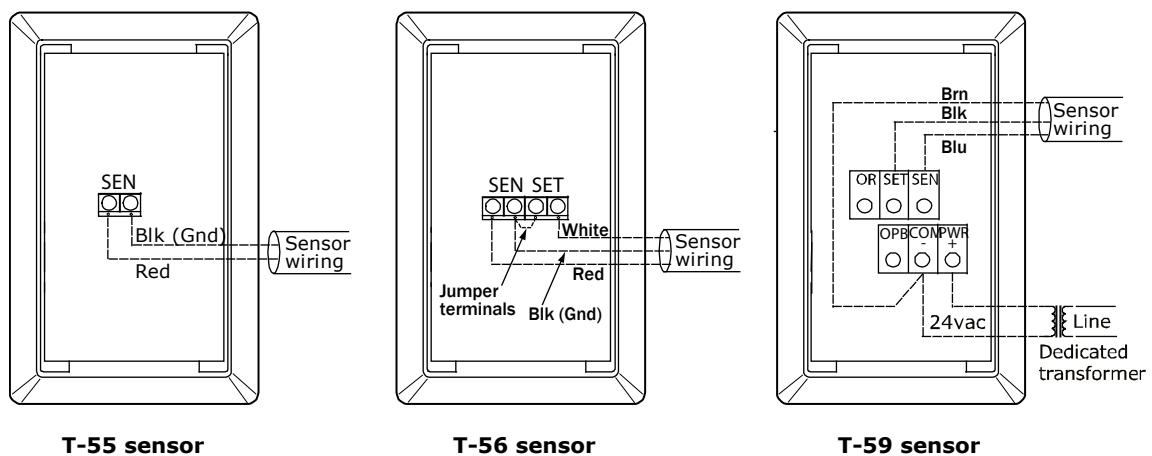

To change a T59 sensor's options

You can change user options and field service options in the T59's display. The options are displayed on pages referenced by page number. See tables below.

NOTE Because the T-59 is not a communicating device, the T-59's setpoint and offset values must be set to match the same values in the associated controller.

To display an option page	<ol style="list-style-type: none"> 1 In the User Options and Field Service Options tables below, find the option you want to change and its page number. 2 With the sensor displaying the current temperature, simultaneously press and hold the ▼ and ▲ keys. After 30 seconds, the sensor's display shows option page 100. 3 Release the keys. 4 Press ▲ repeatedly until the display shows the page number you want. <p>NOTE To display a field service option page (126 to 132), press the ▲ key until you see 1- -, then simultaneously press and hold ▼ and ▲. After approximately 2 seconds, the display shows 126. Press ▲ until you see the page you want.</p> <p>NOTE If you do not press a key for 30 seconds, the sensor automatically returns to normal operation.</p>
To edit a value	<ol style="list-style-type: none"> 1 When the option page you want is displayed, press ▼ to enter edit mode. 2 Press ▲ repeatedly to cycle through the numbers 00 to 12. Stop at the number that represents the value you want. See tables below. 3 Press ▼ to save the selected value and return to option page. <p>NOTE If you do not press a key for 10 seconds, the sensor automatically returns to option page.</p>
To return sensor to normal operation	From an option page, press ▲ until the display shows 1- -. Then press ▼.

User Options

Option page	Description
100	Firmware version
101	Temperature scale 00 = °F 01 = °C
102	Temperature Offset (Sensor Trim) °F 00 = -5 01 = -4 02 = -3 03 = -2 04 = -1 05 = 0 (typical) 06 = 1 07 = 2 08 = 3 09 = 4 10 = 5
103	Normal Setpoint Display 00 to 09 = Do Not Use Offset Setpoint Display 10 = -02 to 02 °F (-02 to 02 °C) 11 = -03 to 03 °F (-03 to 03 °C) 12 = -05 to 05 °F (-05 to 05 °C)
104	Keep at 00

Option page	Description
105	Setpoint Lockout 00 = Disable Lockout 01 = Enable Lockout
106	Keep at 00
107	Keep at 00
108	Display Mode 00 = Normal 01 = Setpoint Only
109	Keep at 00

Field Service Options

Page	Description
126	Setpoint mode 00 = Use option page 103 setting 01 = Display single offset setpoint 02 = Display Heat/Cool setpoints 03 = Display Heat/Cool setpoints w/Occupied (Occupied icon is shown in setpoint display mode.)
127	Setpoint feedback 00 = Disable feedback 01 = Enable Occupied/unoccupied feedback 02 = Enable Heat/Cool feedback
128	Maximum offset adjustment for setpoint * Note: When using the -00° to +00° selection, option page 105 must be set to value 01. * 00 = -00° to +00° (F or C) 01 = -01° to +01° (F or C) 02 = -02° to +02° (F or C) (Default) 03 = -03° to +03° (F or C) 04 = -04° to +04° (F or C) 05 = -05° to +05° (F or C) 06 = -06° to +06° (F or C) 07 = -07° to +07° (F or C) 08 = -08° to +08° (F or C) 09 = -09° to +09° (F or C) 10 = -10° to +10° (F or C)
129	Occupied heat setpoint 60 = Default (Range is 10 to 89)
130	Occupied cool setpoint 65 = Default (Range is 10 to 89)
131	Unoccupied heat setpoint 55 = Default (Range is 00 to 99)
132	Unoccupied cool setpoint 90 = Default (Range is 00 to 99)

Supply Air Temperature sensor

Part #33ZCSENSAT

The Supply Air Temperature (SAT) sensor is required for reheat applications.

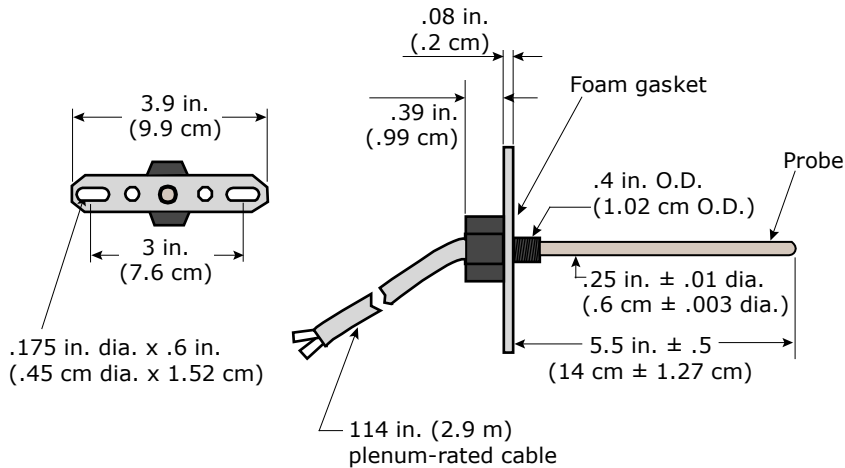

NOTE If state or local code requires the use of conduit, use a *Primary Air Temperature* (page 37) (Part #33ZCSENPAT) sensor instead of an SAT sensor.

SAT sensor specifications

Operating range	-40° to 245° F (-40° to 118° C) with a nominal resistance of 10,000 ohms at 77° F (25° C). See table below.
Sensor tolerance	Accuracy of ±0.36° F (0.2° C) from 0° to 70° C
Physical	Has a thermistor encased with a 6-inch (15.2-cm) stainless steel probe. Includes a 114-inch plenum-rated cable and 2 mounting screws.

**Thermistor Resistance vs. Temperature Values for Supply-air-
Temperature Sensor
10K Type III (CP/MCI)**

Temp (F)	Temp (C)	Resistance (Ohms)
-40	-40	335,651
-31	-35	242,195
-22	-30	176,683
-13	-25	130,243
-4	-20	96,974
5	-15	72,895
14	-10	55,298
23	-5	42,315
32	0	32,651
41	5	25,395
50	10	19,903
59	15	15,714
68	20	12,494
77	25	10,000
86	30	8,056
95	35	6,530
104	40	5,325
113	45	4,367
122	50	3,601
131	55	2,985
140	60	2,487
149	65	2,082
158	70	1,752

Wiring specifications

The sensor includes a 114-inch, plenum-rated cable. To extend the length, use the cable specified below.

Cable from sensor to controller:	If <100 ft (30.5 meters)	22 AWG, unshielded
	If >100 ft (30.5 meters)	22 AWG, shielded
Maximum length:	500 feet (152 meters)	

Mounting location

Mount the SAT in the duct downstream from the air terminal. If the zone has electric reheat, mount the sensor at least 2 feet (.6 m) downstream of the electric heater. If the zone has an octopus connected directly at the discharge, mount the sensor in the octopus.

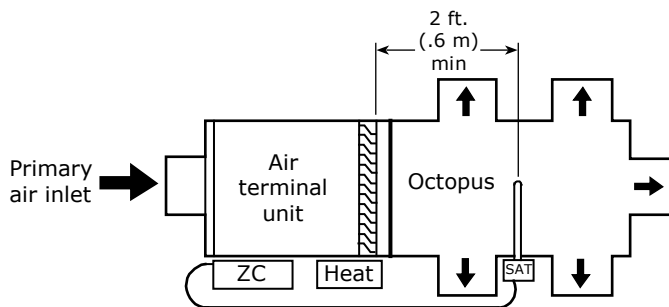
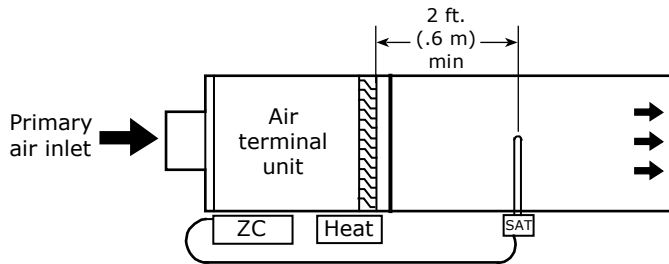

To wire and mount the SAT sensor

- 1 Drill or punch a .5 inch (1.3 cm) hole in the duct.
- 2 Insert the sensor's probe into the hole.
- 3 Secure the sensor to the duct using the 2 mounting screws provided.

CAUTION The tip of the sensor's 6-inch (15.2-cm) probe must not touch the inside of the duct. Use field-supplied bushings as spacers when installing the sensor probe in a duct 6 inches (15.2 cm) or less in diameter.

- 4 Wire the sensor to the Open controller. See the controller's *Installation and Startup Guide* for details.

Duct Air Temperature sensor

Part #33ZCSENDAT

The Duct Air Temperature (DAT) sensor monitors supply air and is required for cooling and heating air source applications on non-Carrier dampers and for stand-alone operation.

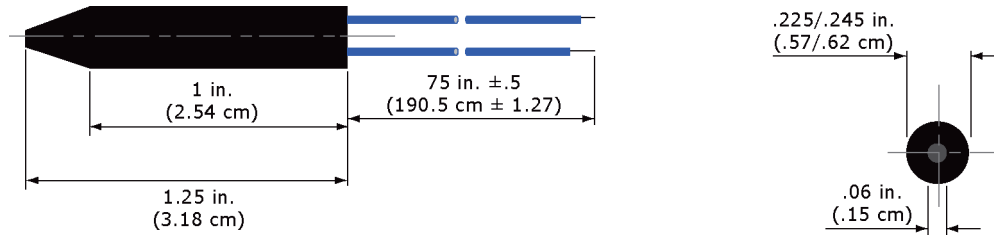

DAT sensor specifications

Operating range	-40° to 245°F (-40° to 118°C) with a nominal resistance of 10,000 ohms at 77°F (25°C). See table below.
Sensor tolerance	Accuracy of ±0.36°F (0.2°C) from 0° to 70°C
Physical	Small, epoxy sensor, 1.25 inch (3.2 cm) long. Includes a mounting grommet and 75-inch cable.

Thermistor Resistance vs. Temperature Values for Duct Temperature Sensor

10K Type III (CP/MCI)

Temp (F)	Temp (C)	Resistance (Ohms)
-40	-40	335,651
-31	-35	242,195
-22	-30	176,683
-13	-25	130,243
-4	-20	96,974
5	-15	72,895
14	-10	55,298
23	-5	42,315
32	0	32,651
41	5	25,395
50	10	19,903
59	15	15,714
68	20	12,494
77	25	10,000
86	30	8,056
95	35	6,530
104	40	5,325
113	45	4,367
122	50	3,601
131	55	2,985
140	60	2,487
149	65	2,082
158	70	1,752

Wiring specifications

The sensor includes a 75-inch cable. To extend the length, use the cable specified below.

Cable from sensor to controller:	If <100 ft (30.5 meters)	22 AWG, unshielded
	If >100 ft (30.5 meters)	22 AWG, shielded
Maximum length:	500 feet (152 meters)	

Mounting location

Mount the sensor in the top or side of the supply duct.

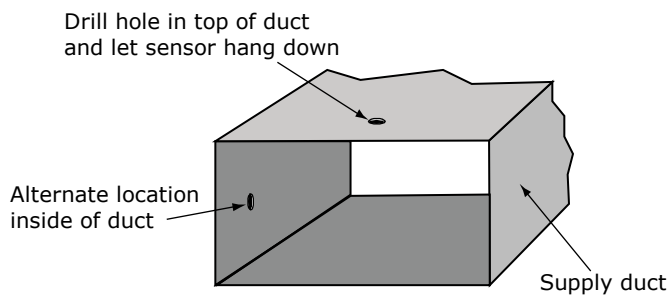

To wire and mount the DAT sensor

- 1 Drill or punch a .25 inch (.6 cm) hole in the top or side of the supply duct.
- 2 Insert the sensor's probe into the hole. The probe can touch side of duct.
- 3 Snap the grommet into the hole until it is secure.
- 4 Pull on the sensor's wiring until the sensor is snug against the grommet.
- 5 Wire the sensor to the Open controller. See the controller's *Installation and Startup Guide* for details.

Outdoor Air Temperature sensor

Part #33ZCSENOAT

The outdoor air temperature (OAT) sensor monitors the temperature of the outside air before it enters the equipment.

NOTE If the sensor is to be installed in the outdoor air duct instead of an outdoor location, use a *Primary Air Temperature* (page 37) (Part #33ZCSENPAT) sensor instead of an OAT sensor.

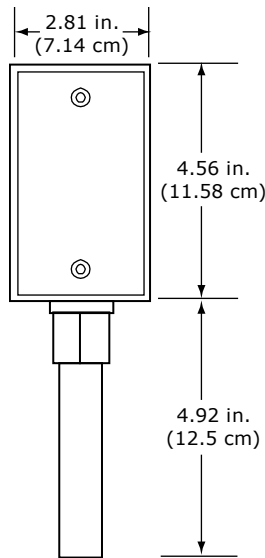

OAT sensor specifications

Operating range	-40° to 245° F (-40° to 118° C) with a nominal resistance of 10,000 ohms at 77° F (25° C). See table below.
Sensor tolerance	Accuracy of ±0.36° F (0.2° C) from 0° to 70° C
Physical	Has a thermistor encased in a plastic resin probe that is enclosed in a PVC housing

**Thermistor Resistance vs. Temperature Values for Outdoor Air
Temperature Sensor
10K Type III (CP/MCI)**

Temp (F)	Temp (C)	Resistance (Ohms)
-40	-40	335,651
-31	-35	242,195
-22	-30	176,683
-13	-25	130,243
-4	-20	96,974
5	-15	72,895
14	-10	55,298
23	-5	42,315
32	0	32,651
41	5	25,395
50	10	19,903
59	15	15,714
68	20	12,494
77	25	10,000
86	30	8,056
95	35	6,530
104	40	5,325
113	45	4,367
122	50	3,601
131	55	2,985
140	60	2,487
149	65	2,082
158	70	1,752

Wiring specifications

Cable from sensor to controller:	If <100 ft (30.5 meters)	22 AWG, unshielded
	If >100 ft (30.5 meters)	22 AWG, shielded
Maximum length:	500 feet (152 meters)	

Mounting location

For applications with an economizer, mount the sensor immediately upstream from the outdoor air damper where it will accurately sense the temperature of the outdoor air entering the mixing box.

For applications without an economizer, mount the sensor in the outdoor air duct near the outdoor air intake or on the northern exterior of the building.

Do not mount the sensor:

- In direct sunlight
- Near the exhaust from air-handling units or compressors
- Near leakage drafts of indoor air
- Near shrubbery or trees
- Under direct water runoff

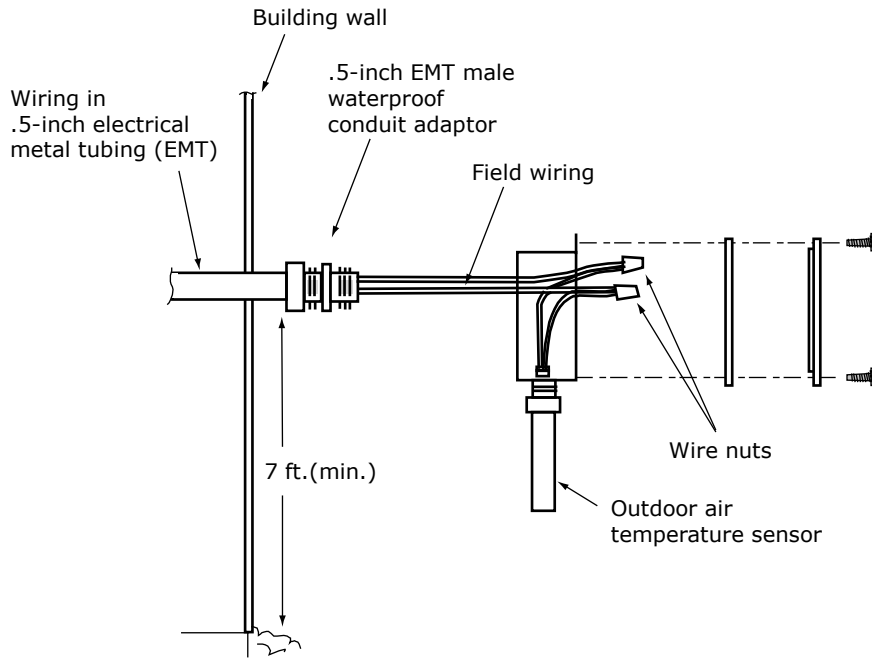

To wire and mount the OAT sensor

- 1 Drill a 7/8" hole in a vertical wall.
- 2 Insert a .5-inch piece of electrical metal tubing (EMT).
- 3 Attach a .5-inch male waterproof conduit adaptor to the end of the EMT.
- 4 Remove the knockout in the back of the OAT sensor.
- 5 Attach the sensor box to the conduit adaptor using the adapter locking nut.
- 6 Replace sensor gasket and cover using the 2 screws provided.
- 7 Wire the sensor to the Open controller. See the controller's *Installation and Startup Guide* for details.

Primary Air Temperature sensor

Part #33ZCSENPAT

The Primary Air Temperature (PAT) sensor monitors the supply air temperature. Use a PAT sensor if state or local code requires the use of conduit. If conduit is not required, you can use an SAT sensor.

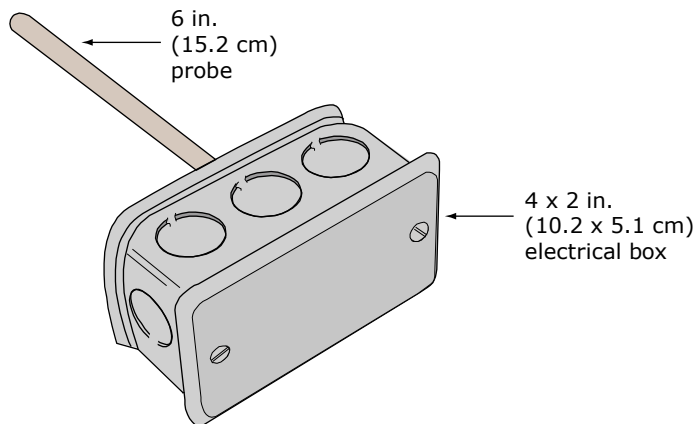

PAT sensor specifications

Operating range	-40° to 245°F (-40° to 118°C) with a nominal resistance of 10,000 ohms at 77°F (25°C). See table below.
Sensor tolerance	Accuracy of $\pm 0.36^\circ\text{F}$ (0.2°C) from 0° to 70°C
Physical	Has a thermistor encased with a 6-inch (15.2-cm) stainless steel probe. Has a 4x2-inch electrical box. Includes 2 mounting screws.

**Thermistor Resistance vs. Temperature Values for Primary Air Temperature Sensor
10K Type III (CP/MCI)**

Temp (F)	Temp (C)	Resistance (Ohms)
-40	-40	335,651
-31	-35	242,195
-22	-30	176,683
-13	-25	130,243
-4	-20	96,974
5	-15	72,895
14	-10	55,298
23	-5	42,315
32	0	32,651
41	5	25,395
50	10	19,903
59	15	15,714
68	20	12,494
77	25	10,000
86	30	8,056
95	35	6,530
104	40	5,325
113	45	4,367
122	50	3,601
131	55	2,985
140	60	2,487
149	65	2,082
158	70	1,752

Wiring specifications

Cable from sensor to controller:	If <100 ft (30.5 meters)	22 AWG, unshielded
	If >100 ft (30.5 meters)	22 AWG, shielded
Maximum length:	500 feet (152 meters)	

Mounting location

Mount the sensor in the top or side of the supply duct.

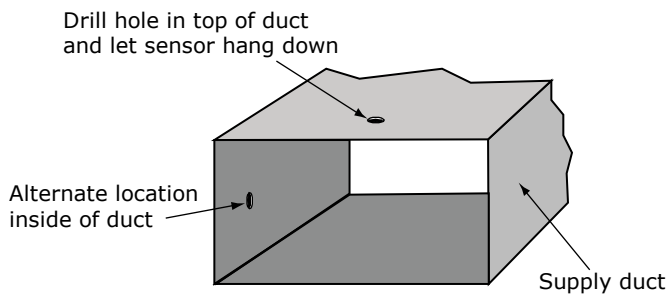

To wire and mount the PAT sensor

- 1 Drill or punch a .5 inch (1.3 cm) hole in the duct.
- 2 Connect a .5 inch (1.3 cm) nominal field-supplied conduit between the zone controller enclosure and the junction box.
- 3 Pass the sensor wires through the conduit.
- 4 Insert the sensor's probe into the hole.
- 5 Secure the sensor to the duct using the 2 mounting screws provided.

CAUTION The tip of the sensor's 6-inch (15.2-cm) probe must not touch the inside of the duct.

- 6 Wire the sensor to the Open controller. See the controller's *Installation and Startup Guide* for details.

CO2 sensor

Part #33ZCSPTCO2LCD-01 (Display model)

Part #33ZCSPTCO2-01 (No display)

Wall-mount or duct-mount

Duct installation requires an Aspirator Box (Part #33ZCASPCO2) to house the CO₂ sensor.

A CO₂ sensor monitors carbon dioxide levels. As CO₂ levels increase, the controller adjusts the outside air dampers to increase ventilation and improve indoor air quality. These sensors monitor temperature using a 10K thermistor, but are not capable of occupancy override.

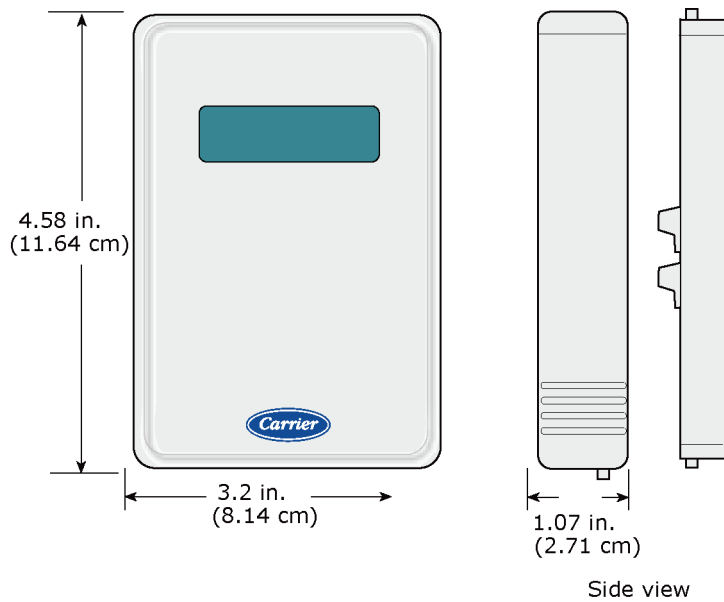

The figure below shows ventilation rates for various CO₂ setpoints when outside air with a typical CO₂ level of 350 ppm is used.

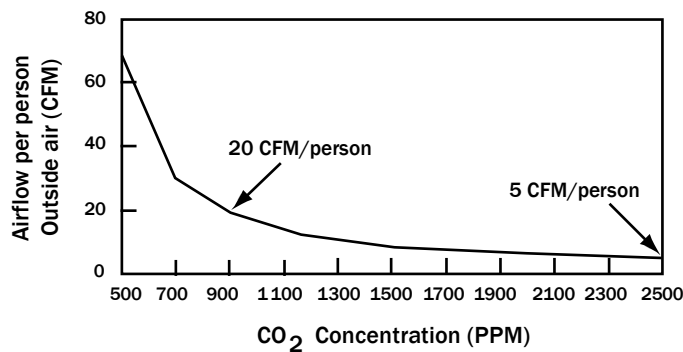

NOTES

- The sensor has a 4–20 mA output that is converted to 0–5 Vdc by a 250 Ohm, 1/4 watt, 2% tolerance resistor connected across the zone controller's CO₂ input terminals.
- Do not use a relative humidity sensor and CO₂ sensor on the same zone controller.

CO2 sensor specifications

Method	Dual Beam Absorption Infrared™ Patented TEMA (time extended measurement algorithm) self-calibration software Optional thermistor temperature measurement Sample Method: Diffusion or flow-thru (50 to 100 ml/min)
Measurement range	Analog Output: 0–2000 ppm factory default adjustable to 10,000 ppm Digital display: 0–10,000 ppm Sensitivity: ± 10 ppm Resolution: ± 1 ppm
Sensor tolerance	Accuracy: Typical Conditions: °60° to 90° F (15° to 32° C) 0–2000 ppm: ± 50 ppm or ± 3% of reading, whichever is greater 2000–10,000 ppm: ± 5% of reading Extended Conditions : 32° to 122° (0° to 50° C) 0–2000 ppm: ± 100 ppm or ± 5%, whichever is greater 2000–10,000 ppm: ± 7% of reading, whichever is greater Pressure Dependence: Add 0.13% of reading per mm Hg decrease from 760 (On board correction, user set)
Annual drift	± 10 ppm (negligible) with TEMA on ± 20 ppm typical with TEMA off Response Time: 0–90% FS < 2 minutes Warm-Up Time: 25 C < 2 minutes Operating Conditions: 32° to 122° F (0° to 50° C) 0–95% RH (relative humidity), non-condensing Storage Conditions: –40° to 158° F (–40° to 70° C)
Power	Requires a dedicated 24 Vac, 3 Va transformer
Certification	FCC Part 15 Class B Calibration Interval: Five years/zero ppm gas offset adjust

Wiring specifications

Cable from sensor to controller:	If <100 ft (30.5 meters)	22 AWG, unshielded
	If >100 ft (30.5 meters)	22 AWG, shielded
Maximum length:	500 feet (152 meters)	

Mounting location

A CO₂ sensor can be wall-mounted or mounted in a return air duct. (Duct installation requires an Aspirator Box Accessory - Part #33ZCASPCO2.)

Wall mounting

Mount the sensor:

- Near the return air grill to sense the concentration of CO₂ leaving the space
- At least 3 feet (.9 m) from any corner

Do not mount the sensor:

- Where it can have direct breath contact
- In drafty areas such as near supply ducts, open windows, or fans
- Over heat sources
- Where it can be influenced by the supply air. The sensor gives inaccurate readings if the supply air blows directly onto the sensor or the supply air does not have a chance to mix with the room air before it is drawn into the return air stream.

NOTE The sensor mounting plate accommodates the NEMA standard 2x4 in. standard single gang electrical box. However, the sensor can be mounted directly on the wall surface if local codes permit.

Duct mounting

Mount the sensor:

- In a duct that has a diameter or depth of at least 9 inches (22.9 cm)
- At least 6 inches (15.2 cm) upstream or 15 inches (38.1 cm) downstream of a 90-degree turn in the return air duct. The downstream location is preferred.
- In the center of the duct
- Where at least 1 foot (.3 m) of space in front of the sensor is free of obstruction

To wire and wall-mount the CO2 sensor

- 1 Turn the setscrew at the bottom of the sensor clockwise to release the sensor's cover from the mounting plate.
- 2 Lift the cover from the bottom, and then release it from the top fasteners.
- 3 Feed the wires from the electrical box through the opening in the center of the sensor mounting plate.
- 4 Use the 2 mounting screws provided to attach the mounting plate to the electrical box.
- 5 Wire the 24 Vac transformer to the sensor. See diagram below.
- 6 Turn the two Allen screws at the bottom of the unit counterclockwise to secure the cover to the mounting plate.
- 7 Wire the sensor to the Open controller. See the controller's *Installation and Startup Guide* for details.

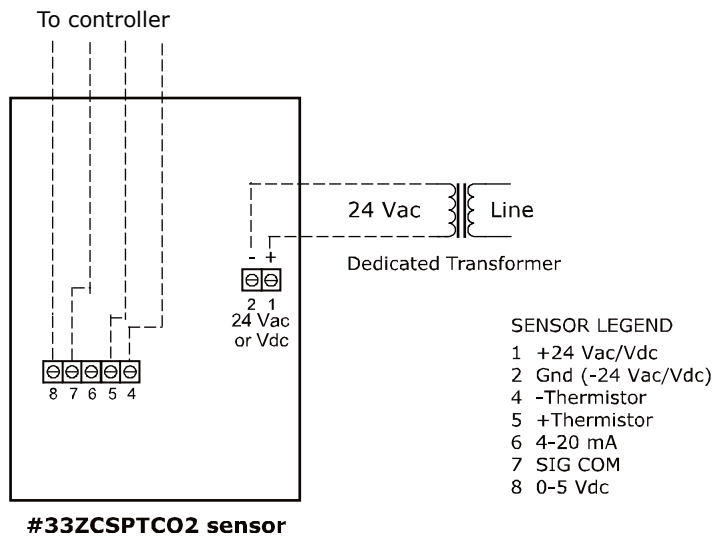

To wire and duct-mount the sensor

Duct installation requires the Aspirator Box Accessory (Part #33ZCASPCO2) to house the CO₂ sensor.

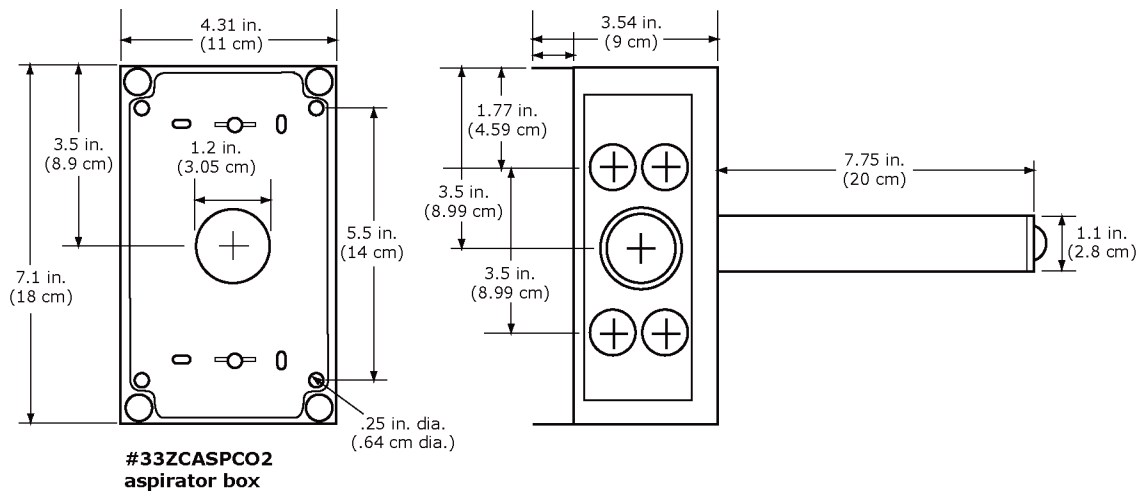

To mount the aspirator box and sensor:

- 1 Drill a 1.25 inch (3.18 cm) hole in the return duct.
- 2 Remove the aspirator box cover.
- 3 Insert the aspirator box sampling tube into the hole.
- 4 Secure the box to the duct using 2 field-supplied #8 x 1" sheet metal screws.
- 5 Remove .5 inch (1.3 cm) conduit knockout, then install the conduit fittings.
- 6 Mount the CO₂ sensor in the aspirator box using 2 field-supplied #8 x 32 machine screws.
- 7 To wire the CO₂ sensor, see the instructions above in *To wire and wall-mount the CO₂ sensor* (page 42).
- 8 Install the aspirator box cover.

CO2/Temperature sensor

Part #33ZCT55CO2
 Part #33ZCT56CO2

A CO₂/space temperature sensor houses two sensors in a single unit. This sensor uses Single Beam Absorption Infrared™ diffusion technology to monitor carbon dioxide (CO₂) levels and has a 10K thermistor to measure space temperature. The controller uses this information to adjust the outside air dampers to provide proper ventilation and control space temperature.

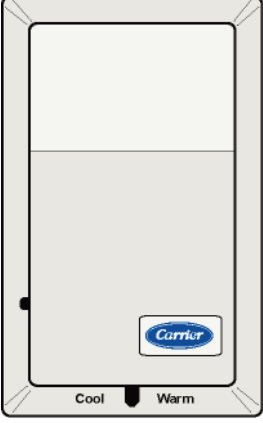
Sensor		Features
33ZCT55CO2		<ul style="list-style-type: none"> • CO₂ sensor • Space temperature sensor • Push-button override
33ZCT56CO2		<ul style="list-style-type: none"> • CO₂ sensor • Space temperature sensor • Push-button override • Set point adjustment

NOTES

- The sensor has a 4–20 mA or 0–10 V output.
- Push button override
- Do not use a relative humidity sensor and CO₂ sensor on the same zone controller.

CO2/Temperature sensor specifications

Method	Dual Beam Absorption Infrared™ Patented TEMA (time extended measurement algorithm) self-calibration software 10K Temperature sensor Sample Method: Diffusion	
Measurement range	Analog Output: 0–2000 ppm factory default adjustable to 10,000 ppm	
Sensor tolerance	Accuracy: Typical Conditions: °60° to 90° F (15° to 32° C) 0–2000 ppm: ± 110 ppm	
Annual drift	± 10 ppm (negligible) with TEMA on ± 20 ppm typical with TEMA off Response Time: 0–90% FS < 2 minutes Warm-Up Time: 25 C < 2 minutes Operating Conditions: 32° to 122° F (0° to 50° C) 0–95% RH (relative humidity), non-condensing Storage Conditions: –4° to 158° F (–20° to 70° C)	
Power	18-30 Vac RMS, 50/60 Hz - half wave rectified (dedicated) 18-42 Vdc polarity protected (dedicated) 1.75 Va maximum average power 2.75 Va peak power	
Analog CO2 Output	4-20 mA (RLmax=500 Ohms) and 0–10 V (Source 100 mA, Sink 10 mA)	
Temperature Sensor	10 kOhm Thermistor, 10 kOhm ± 2.5% at 77° F (25° C)	
Temperature Control (#33ZCT56CO2 only)	Slide potentiometer position	Resistance
	Left stop	0 kOhms (+5 kOhms)
	Right stop	100 kOhms (± 10 kOhms)
Certification	FCC Part 15 Class B Calibration Interval: Five years/zero ppm gas offset adjust	
Mounting	5 1/4 in. (13.3 cm) x 3 in. (7.6 cm) molded plastic. Includes 6x32 machine screws.	

Wiring specifications

Cable from sensor to controller:	If <100 ft (30.5 meters)	22 AWG, unshielded
	If >100 ft (30.5 meters)	22 AWG, shielded
Maximum length:	500 feet (152 meters)	

Mounting location

This sensor must be placed in an area that is representative of the conditional space or zone.

Wall mounting

Mount the sensor:

- On an internal wall near a return air grille or duct
- At least 3 feet (.9 m) from any corner, 2 feet from an open doorway and 4 to 6 feet from the floor
- Proximal to the wiring egress on the wall
- Where the temperature operating limits are 32° to 122° F

Do not mount the sensor:

- Close to a window, on an outside wall, or next to a door leading to the outside
- Close to or in direct airflow of areas such as open windows, drafts or over heat sources
- In areas with poor circulation
- Where it may be exposed to direct occupant breathing such as near water coolers or coffee machines

NOTE The sensor mounting plate accommodates the NEMA standard 2x4 in. standard single gang electrical box. However, the sensor can be mounted directly on the wall surface if local codes permit.

To wire and mount the CO2/Temperature sensor

- 1 Disassemble the sensor into these three parts: sensor cover, sensor base and mounting plate.
- 2 Feed the wires from the electrical box through the opening in the center of the sensor mounting plate.
- 3 Use the 2 mounting screws provided to attach the mounting plate to the electrical box.
- 4 Run the wiring through the wire hole in the sensor base. See diagram below.
- 5 Reattach the sensor's base to the mounting plate, inserting the top first.
- 6 Separate the wires into two bundles: one bundle for the CO₂ sensor wires (J4 and J1), the other bundle for the temperature sensor and CCN wires (J5 and J6).
- 7 Use the diagram below to connect the wiring to the sensor's J1, J4, J5, and J6 terminals.

NOTE On a large number of sensors, J6 was labeled incorrectly with CCN+ and CCN-. Ignore the labels on the circuit board and use the wiring diagram in this book.

- 8 Push excess wire back through the hole.
- 9 Reattach the sensor's cover to the base and mounting plate.
- 10 Turn the two Allen screws counterclockwise to secure the cover to the mounting plate.
- 11 Wire the sensor to the Open controller. See the controller's *Installation and Startup Guide* for details.

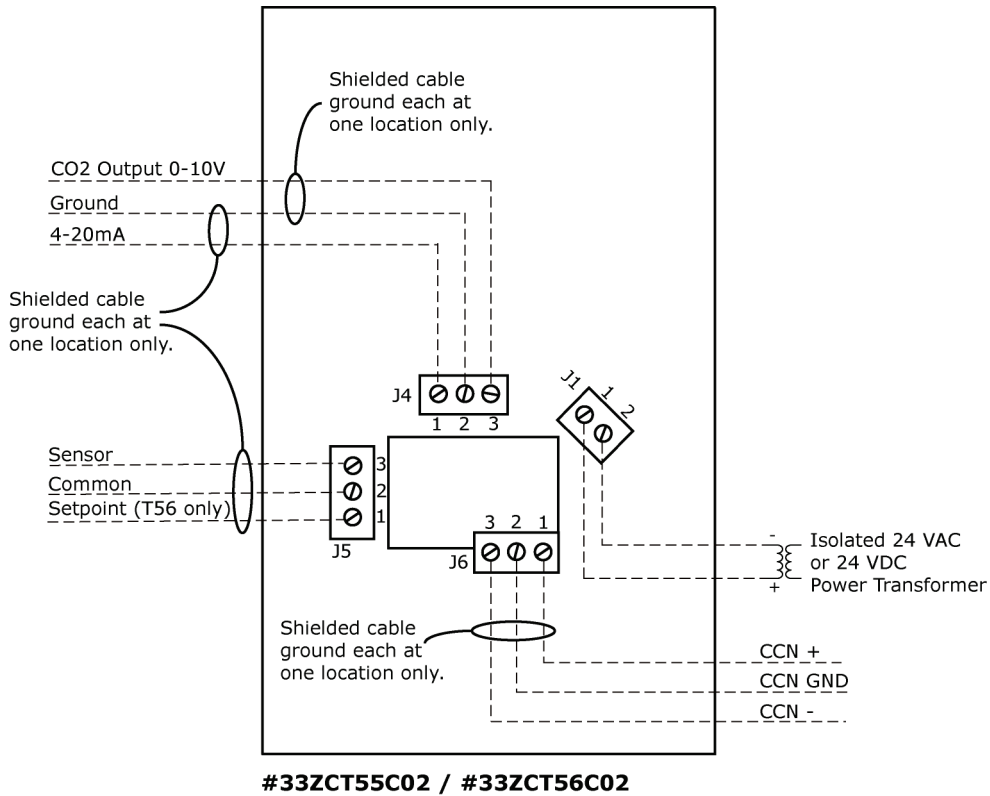

Relative Humidity sensors

Carrier offers 4 Relative Humidity sensors:

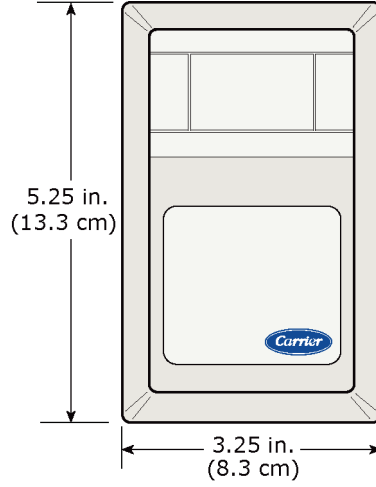
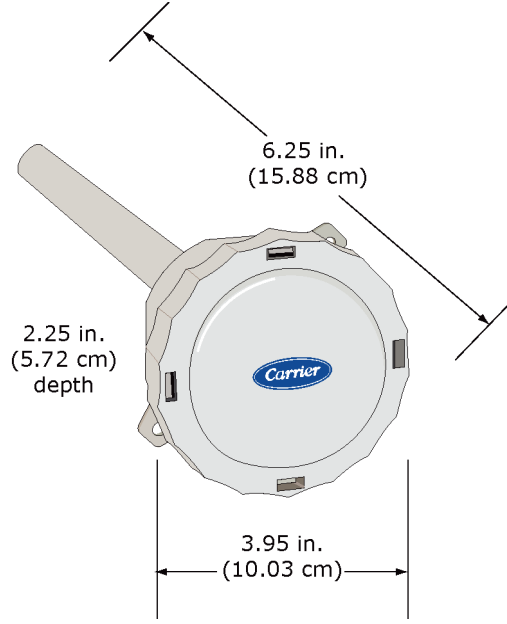
Sensor		Usage
<p>Space Relative Humidity sensor Part #33ZCSENSRH-02</p>	 <p>5.25 in. (13.3 cm)</p> <p>3.25 in. (8.3 cm)</p>	<p>Controls zone humidity (dehumidification) if the rooftop unit has a dehumidification device. If not, the sensor only monitors humidity.</p> <p>Can output 0-5 or 0-10 Vdc or 4-20 mA.</p>
<p>Duct Relative Humidity sensor Part #33ZCSENDRH-02</p>	 <p>6.25 in. (15.88 cm)</p> <p>2.25 in. (5.72 cm) depth</p> <p>3.95 in. (10.03 cm)</p>	<p>Measures humidity in duct.</p>

Sensor	Usage
Outdoor Relative Humidity sensor Part #33ZCSENORH-02	Measures outdoor humidity.
<p>The diagram shows a cylindrical sensor with a circular top face and a narrower base. The top face has a 'Carrier' logo. Dimension lines indicate: a depth of 2.25 in. (5.72 cm) from the top face to the base; a width of 3.95 in. (10.03 cm) across the top face; and a total height of 4.68 in. (11.89 cm) from the top face to the bottom of the base.</p>	

CAUTION Do not use a relative humidity sensor and CO₂ sensor on the same zone controller.

Sensor specifications

Operating temperature	40° to 130° F (-4° to 54° C)	
Humidity	0 to 99%, non-condensing	
Sensor tolerance	Accuracy at 25° C:	$\pm 2\%$ RH from 10–80% $\pm 3\%$ RH from 80–99%
Power	18-36 Vdc 24 Vac half-wave rectified	
Output	#33ZCSENSRH-02, #33ZCSENDRH-02, and #33ZCSENORH-02:	4-20 mA, 0-5 Vdc, and 0–10 Vdc
Physical	Includes a 499 Ohm 1 Watt resistor for conversions of the 4–20 mA signal to a +2–10 Vdc output signal	

Wiring specifications

Cable from sensor to controller:	If <100 ft (30.5 meters)	22 AWG, unshielded
	If >100 ft (30.5 meters)	22 AWG, shielded
Maximum length:	500 feet (152 meters)	

Mounting location

Mount this sensor...	In this location
Space RH sensor	<ul style="list-style-type: none"> On an interior wall Approximately 5 feet (1.5 meters) from the floor, beside the space temperature sensor At least 4 feet (1.2 meters) from any corner. Reduced airflow in corners results in erratic sensor readings. Vertically so that the Carrier logo is correctly oriented <p>Do not mount the sensor:</p> <ul style="list-style-type: none"> In drafty areas such as near heating or air-conditioning ducts, open windows, or fans Over heat sources such as baseboard heaters, radiators, or wall-mounted light dimmers In areas of excessive moisture, corrosive fumes, or vibration <p>Sensors mounted in these areas will produce inaccurate readings.</p> <p>NOTE The sensor mounting plate accommodates the NEMA standard 2x4 in. standard single gang electrical box. However, the sensor can be mounted directly on the wall surface if local codes permit.</p>
Duct RH sensor	The zone's return air duct
Outdoor RH sensor	Where the sensor is protected from the elements and direct sunlight, such as under an eave

To wire and mount the Space RH sensors

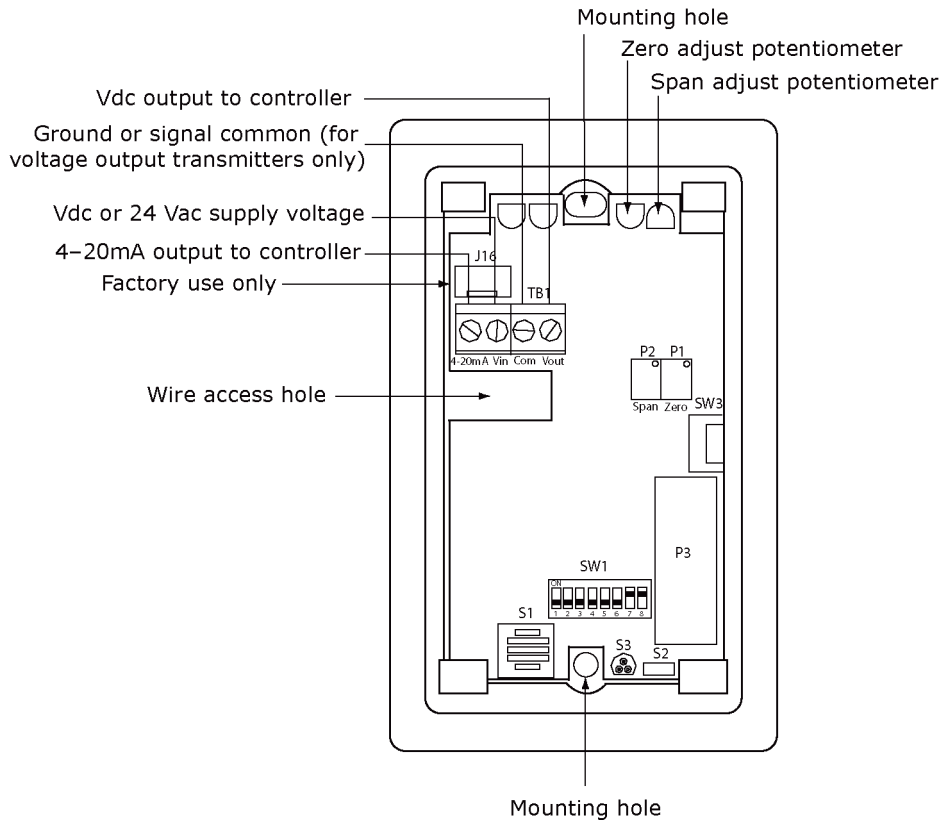

- 1 Remove the sensor's cover from the mounting plate.
- 2 Feed the wires from the electrical box through the wire access hole in the center of the sensor mounting plate.
- 3 Use the 2 screws provided to attach the mounting plate to the electrical box.
- 4 Strip the outer jacket from the cable for at least 4 inches (10.2 cm). Strip .25 inch (.6 cm) of insulation from each wire.
- 5 Wire the unit for power. See *Typical power wiring diagrams for Space RH sensors* (page 53).

- 6** Wire the sensor to the Open controller. See diagrams below and the controller's *Installation and Startup Guide* for details.

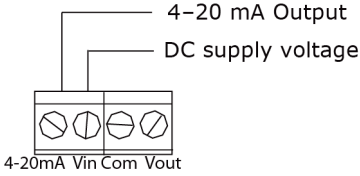
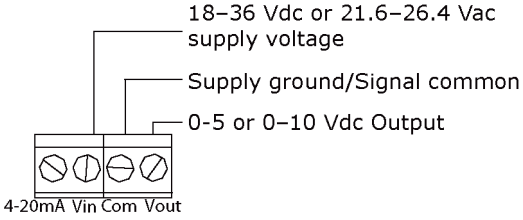
Input	Output	Wiring diagram
18–36 Vdc	4–20 mA	
18–36 Vdc or 21.6–26.4 Vac	0–10 Vdc	

- 7** Reattach the cover to the mounting plate.
- 8** Turn the two Allen screws at the bottom of the unit counterclockwise to secure the cover to the mounting plate.

NOTES

- All wiring should be in accordance with all Local and National Electrical Code guidelines.
- If using shielded cable, connect only one end of the shield to ground at the controller. Connecting both ends to ground may cause a ground loop.

Typical power wiring diagrams for Space RH sensors

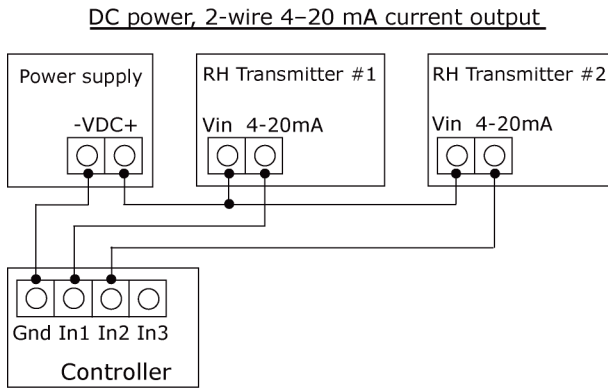

4-20 mA Set all SW1 switches OFF

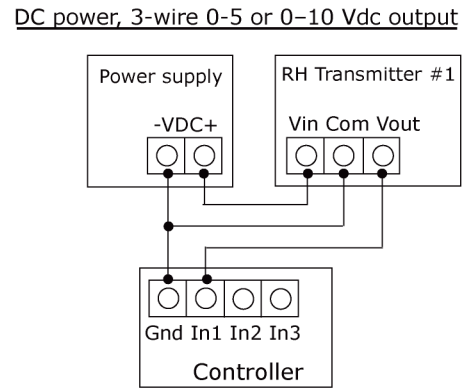

0-5 Vdc Set SW1 switches 6 and 7 ON



0-10 Vdc Set SW1 switches 7 and 8 ON

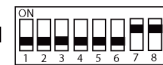

AC power, 3-wire 0-5 or 10 Vdc output

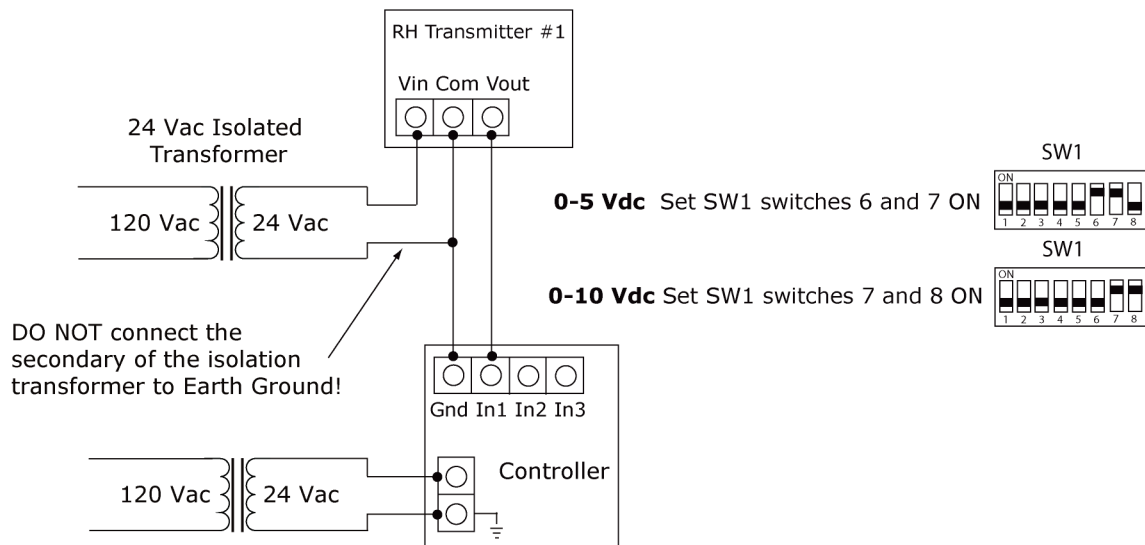

CAUTION If using a 24 Vac transformer, use an isolated transformer. If sharing the transformer with your controller or another device, be sure to connect all of the devices with the proper polarity, since most controllers are earth grounded. Failure to do so could cause a ground loop that could damage the devices.

To wire and mount the Duct RH sensor

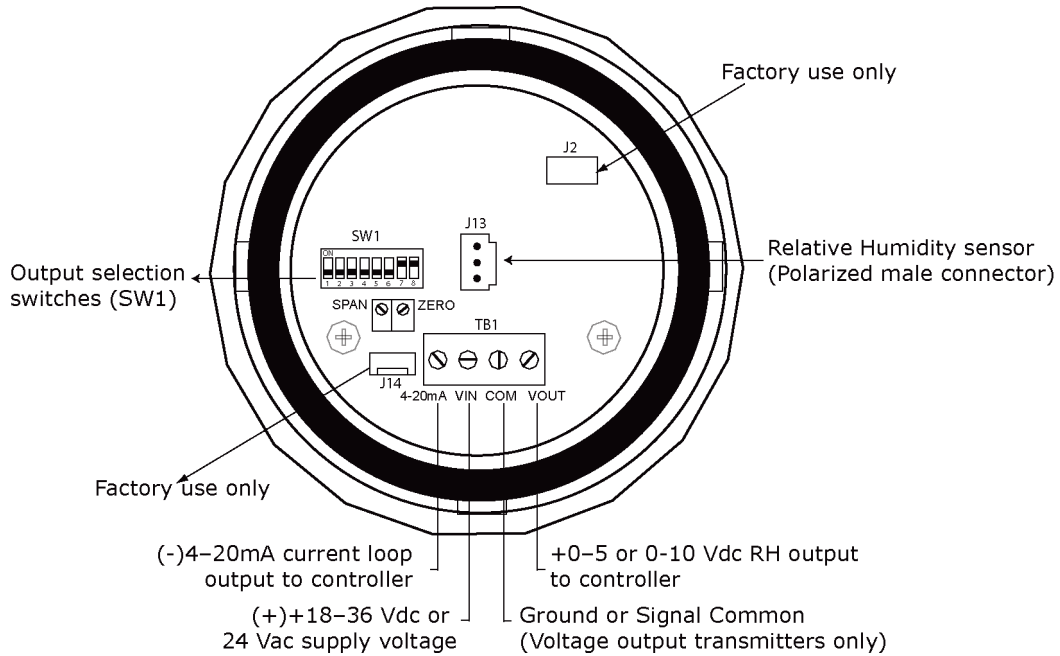

- 1 Drill a .75 inch (1.9 cm) diameter hole in the duct where the sensor is to be mounted.
- 2 Insert the stainless steel probe into the hole until the foam contacts the duct, then attach the RH sensor using the 2 self-tapping screws provided.
- 3 Remove the cover.
- 4 On the probe unit, remove the knockout's inner ring.
- 5 If you are not using a .5 inch (1.3 cm) NPT conduit fitting, remove the knockout's outer ring. Tap the ring in 1 or 2 locations with a screwdriver, then remove the ring.
- 6 Install your conduit connectors or watertight fittings.
- 7 Wire the unit for power. See *Typical power wiring diagrams for Duct RH and Outdoor RH sensors* (page 56).
- 8 Wire the sensor to the Open controller. See diagrams below and the controller's *Installation and Startup Guide* for details.

Input	Output	Wiring diagram
18-36 Vdc	4-20 mA	

Input	Output	Wiring diagram
18–36 Vdc or 21.6–26.4 Vac	0–10 Vdc	

9 Place the sensor's cover onto the probe unit and gently turn until it is tight.

10 Verify that you are getting a humidity reading.

NOTE Allow up to 20 minutes after powering up for the sensor reading to stabilize.

To wire and mount the Outdoor RH sensor

See sensor diagram in *To wire and mount the Duct RH sensor* (page 54).

1 Use the 2 mounting screws provided to secure the sensor.

2 Remove the cover and install conduit connectors, watertight fittings, and/or 1/2" vent plug.

NOTE The inner ring will knock out first. Then tap the outer ring in 1 or 2 locations with a screwdriver to peel it out. The cover will be connected to the housing by the sensor leads.

3 At the sensor end of the cable, strip back the jacket from the cable for at least 3 inches. Strip 1/4 inch of insulation from each conductor. If using shielded cable, cut the shield and drain wire from the cable.

4 Wire the unit for power. See *Typical power wiring diagrams for Duct RH and Outdoor RH sensors* (page 56).

5 Wire the sensor to the Open controller. See diagrams below and the controller's *Installation and Startup Guide* for details.

Input	Output	Wiring diagram
15–36 Vdc	4–20 mA	
18–36 Vdc or 21.6–26.4 Vac	0–10 Vdc	

- 6 Place the cover onto the unit and gently turn until it is tight.
- 7 Verify that you are getting a humidity reading.

NOTE Allow up to 20 minutes after powering up for the sensor reading to stabilize.

Typical power wiring diagrams for Duct RH and Outdoor RH sensors

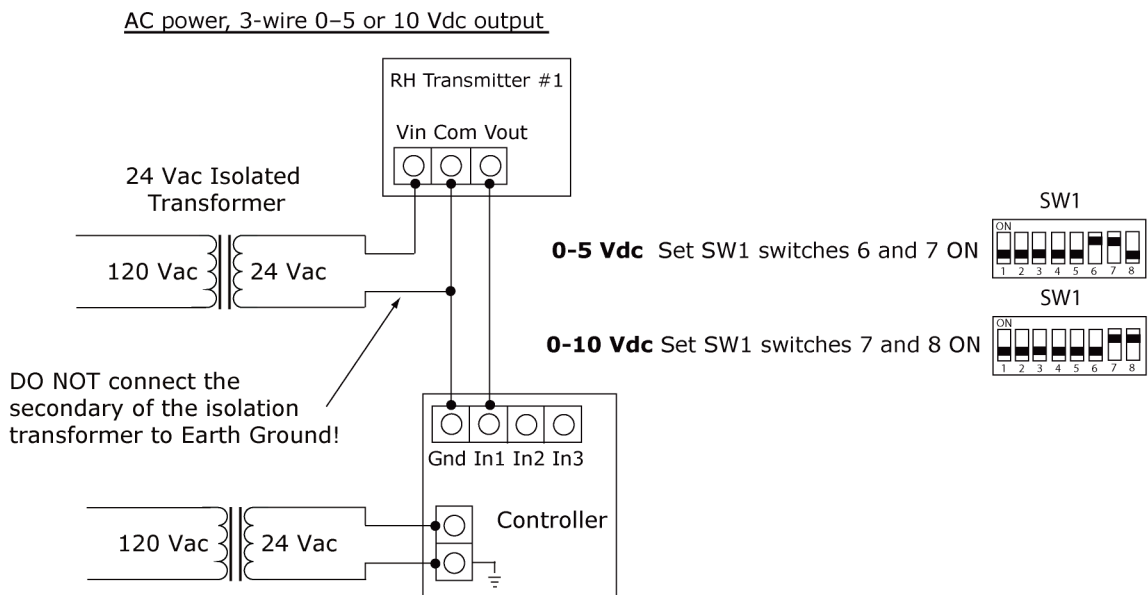
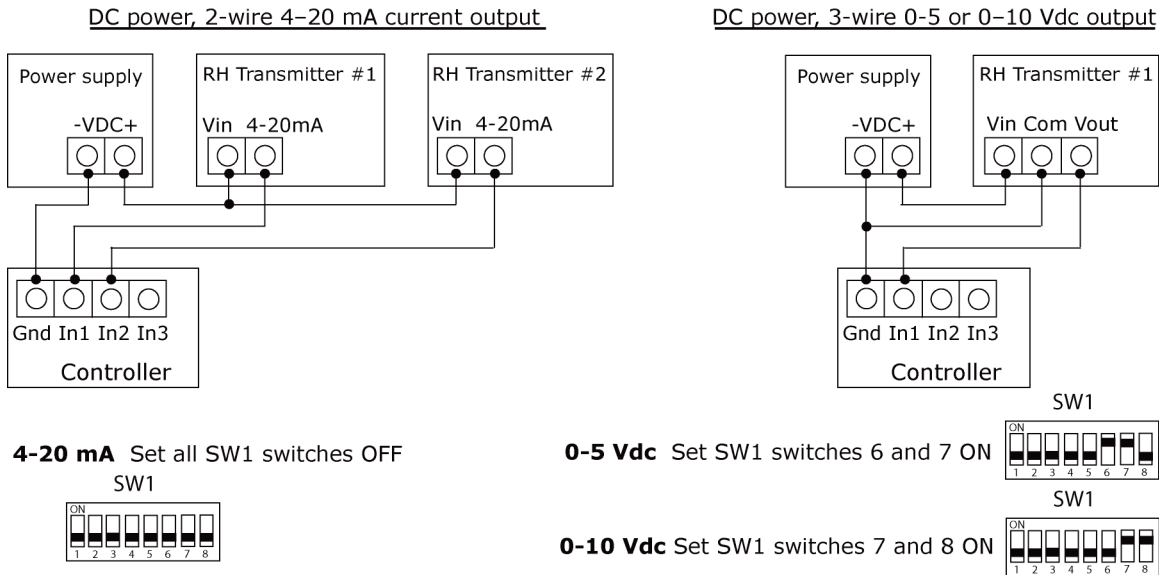

CAUTION If using a 24 Vac transformer, use an isolated transformer. If sharing the transformer with your controller or another device, be sure to connect all of the devices with the proper polarity, since most controllers are earth grounded. Failure to do so could cause a ground loop that could damage the devices.

Calibrating and troubleshooting relative humidity sensors

Troubleshooting the RH sensor



No reading	Verify that: <ul style="list-style-type: none"> You have the correct supply voltage at the power terminal blocks. The wiring configuration and DIP switch settings are correct. All terminal screw connections are tight and that all wires are firmly in place.
Erratic readings	Verify that: <ul style="list-style-type: none"> All wires are terminated properly. The board does not have condensation on it. The input power is clean. In areas of high RF interference or noise, shielded cable may be needed to stabilize the signal.
Inaccurate readings	If you suspect the transmitter is not reading within the specified tolerance, contact the factory for assistance.

Using SW1 DIP switches to calibrate and troubleshoot

This is a single point calibration only. All transmitters are factory-calibrated to meet/exceed published specifications. Field adjustment should not be necessary.

The DIP switch allows you to calibrate the sensor through software. Setting DIP switch 4 ON puts the transmitter into setup mode, allowing the increment and decrement to work. Once in setup mode, the output changes to 50% (5V for 0-10V, 12mA for 4-20mA). Each increment or decrement step causes the output to change by 0.2V for 0-10V, and 0.32mA for 4-20mA in setup mode. This shows how far offset the transmitter is. To see the starting point again, set DIP switch 1 to ON. This shows the 50% output again. When the unit is out of setup mode, the output returns to RH output.

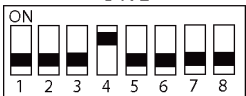
When all calibration is completed, remember to place the switches back into positions that correspond to the output needed.

Normal Operating Condition		Setting DIP switch 4 ON puts the transmitter into setup mode. Once in setup mode, the output changes to 50% (5V for 0-10V, 12mA for 4-20mA).
0% RH Output		Transmitter outputs a 4 mA or 0 Vdc signal regardless of sensor reading. (For troubleshooting only.)

50% RH Output		Transmitter outputs a 12 mA, 2.5 Vdc, or 5 Vdc signal regardless of sensor reading. (For troubleshooting only.)
100% RH Output		Transmitter outputs a 20 mA, 5 Vdc, or 10 Vdc signal regardless of sensor reading. (For troubleshooting only.)
Increment RH Output		Shifts the RH output linearly up in 0.5% steps. Switch 4 must be set to ON first. After switch 4 is ON, each time switch 5 if set to ON, the RH output increases by 0.5%.
Decrement RH Output		Shifts the RH output linearly down in 0.5% steps. Switch 4 must be set to ON first. After switch 4 is ON, each time switch 6 if set to ON, the RH output decreases by 0.5%.
Reset to Original Calibration		Resets the RH output back to the original calibration. Switch 4 must be set to ON first. After switch 4 is ON, toggle switches 5 and 6 ON then OFF. After 5 and 6 are OFF, slide switch 4 OFF.

RH conversion formulas

Use the following table to convert transmitter output signal to %RH.

Output	Example: If signal output is...	Calculation is...
4-20 mA 4 mA = 0% RH 20 mA = 100% RH	12 mA	$(12\text{mA}-4\text{mA})/0.16 = 50\% \text{ RH}$
0-10 Vdc 0 Vdc = 0% RH 10 Vdc = 100% RH	8 Vdc	$8 \text{ Vdc}/0.10 = 80\% \text{ RH}$
0-5 Vdc 0 Vdc = 0% RH 5 Vdc = 100% RH	2 Vdc	$2 \text{ Vdc}/0.05 = 40\% \text{ RH}$

Enthalpy switch/receiver and Enthalpy sensor

Enthalpy switch/receiver - Part #33CSENTHSW
 Enthalpy sensor - Part #33CSENTSEN

Outdoor enthalpy control

Requires a field-installed enthalpy switch/receiver. The enthalpy switch/receiver, mounted in the outdoor air intake, senses temperature and humidity of the surrounding air and calculates the enthalpy.

The enthalpy switch/receiver:

- Energizes the relay output when the outdoor enthalpy is above 28 BTU/lb OR dry bulb temperature is above 75° F
- De-energizes the relay output when the outdoor enthalpy is below 27 BTU/lb AND dry bulb temperature is below 74.5° F.

The relay output is wired to the unit economizer which opens or closes based on the output of the switch.

Differential enthalpy control

Requires an enthalpy switch/receiver and an enthalpy sensor. The enthalpy switch/receiver, mounted in the outdoor air intake, calculates outdoor air enthalpy. The enthalpy sensor, mounted in the return airstream, calculates the indoor air enthalpy.

The enthalpy switch/receiver energizes:

- The HI Enthalpy relay output when the outdoor enthalpy is greater than the indoor enthalpy
- The LOW Enthalpy terminal when the outdoor enthalpy is lower than the indoor enthalpy

The relay output is wired to the unit economizer which opens or closes based on the output of the switch.

NOTE The enthalpy is calculated using an average altitude of 1000 ft above sea level.

Enthalpy switch/receiver

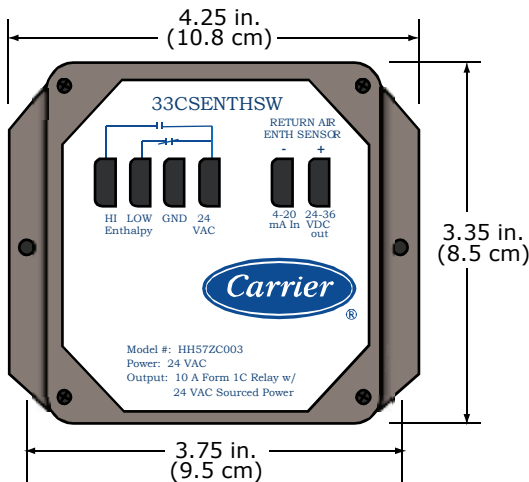

Enthalpy sensor

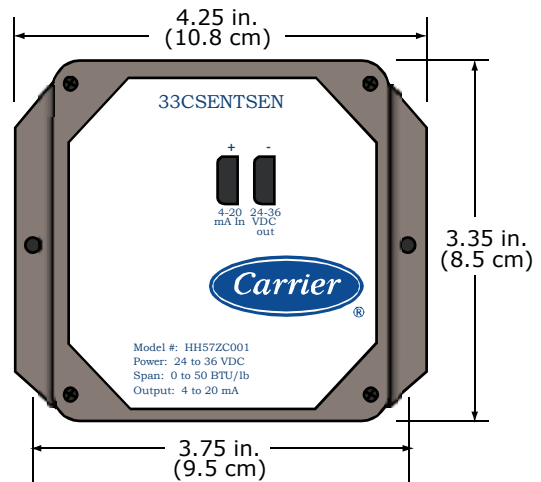

Enthalpy switch/sensor specifications

The following specifications are the same for the switch/receiver and sensor unless noted.

Supply voltage	Switch/Receiver:	24 Vac \pm 15%
	Sensor:	24 to 36 Vdc
Operating range	-40° to 140°F (-40° to 60°C)	
Operating relative humidity	0 to 100%, non-condensing	
Output	Switch/Receiver:	Sourced 24 Vac through 10 Amp Form 1C relay
	Sensor:	2-wire, 4-20 mA loop powered
Enthalpy range	Sensor only	0-50 Btu/lb
Enthalpy accuracy	\pm 1 Btu/lb at 77°F (25°C)	
Temperature accuracy	\pm 0.36°F (0.2°C) from 32 to 158°F (0 to 70°C)	
Relative humidity accuracy	\pm 3% at 77°F (25°C)	
Sensitivity	0.1% RH	
Repeatability	0.5% RH	
Hysteresis	< 0.4% RH	
Stability	< 2% drift over 5 years	

Wiring specifications

Cable from sensor to controller:	If <100 ft (30.5 meters)	22 AWG, unshielded
	If >100 ft (30.5 meters)	22 AWG, shielded
Maximum length:	500 feet (152 meters)	

Mounting location

Mount the enthalpy switch/receiver in the outdoor air intake.

Mount the enthalpy sensor in the return air duct.

Do not mount the enthalpy switch/receivers and sensors where they could be exposed to outdoor elements such as rain or snow. These units are not NEMA 4 enclosures.

To wire and mount the switch/sensor

For Outdoor Enthalpy Control

- 1 To mount the enthalpy switch/receiver, insert 2 field-supplied 8 x 3/4-in. TEK screws through its side holes.
- 2 Remove the 4 screws holding the cover on, then remove cover.
- 3 Set the **M1** to **M3** jumper to **M2**. Leave the other jumper on **Off**.
- 4 Replace the cover and the 4 screws.
- 5 Connect the **GND** and **24 Vac** terminals on the enthalpy switch/receiver to the controller's power terminals.
- 6 Connect the **HI** or **LOW** terminals on the enthalpy switch/receiver to the controller's J2-6 input.

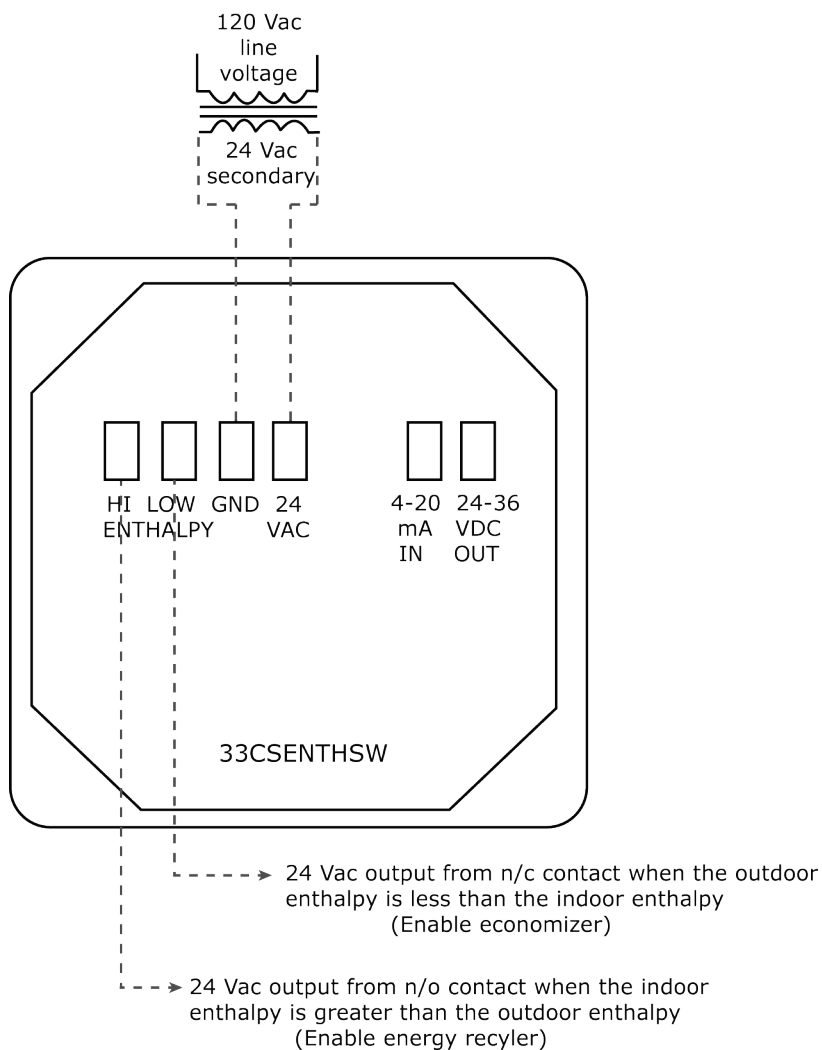

For Differential Enthalpy Control

- 1 To mount the enthalpy sensor, insert 2 field-supplied 8 x 3/4-in. TEK screws through its side holes.
- 2 Repeat step 1 to mount the enthalpy switch/receiver.
- 3 On the switch/receiver, remove the 4 screws holding the cover on, then remove cover.
- 4 Set the **M1** to **M3** jumper to **M2**. Leave the other jumper on **Off**.
NOTE The enthalpy sensor's jumpers should be left at their factory settings of **M3** and **Off**.
- 5 Replace the switch/receiver's cover and the 4 screws.
- 6 Wire the sensor to the switch/receiver. See figure below.
- 7 Connect the **GND** and **24 Vac** terminals on the enthalpy switch/receiver to the controller's power terminals.
- 8 Connect the **HI** or **LOW** terminals on the enthalpy switch/receiver to the controller's J2-6 input.

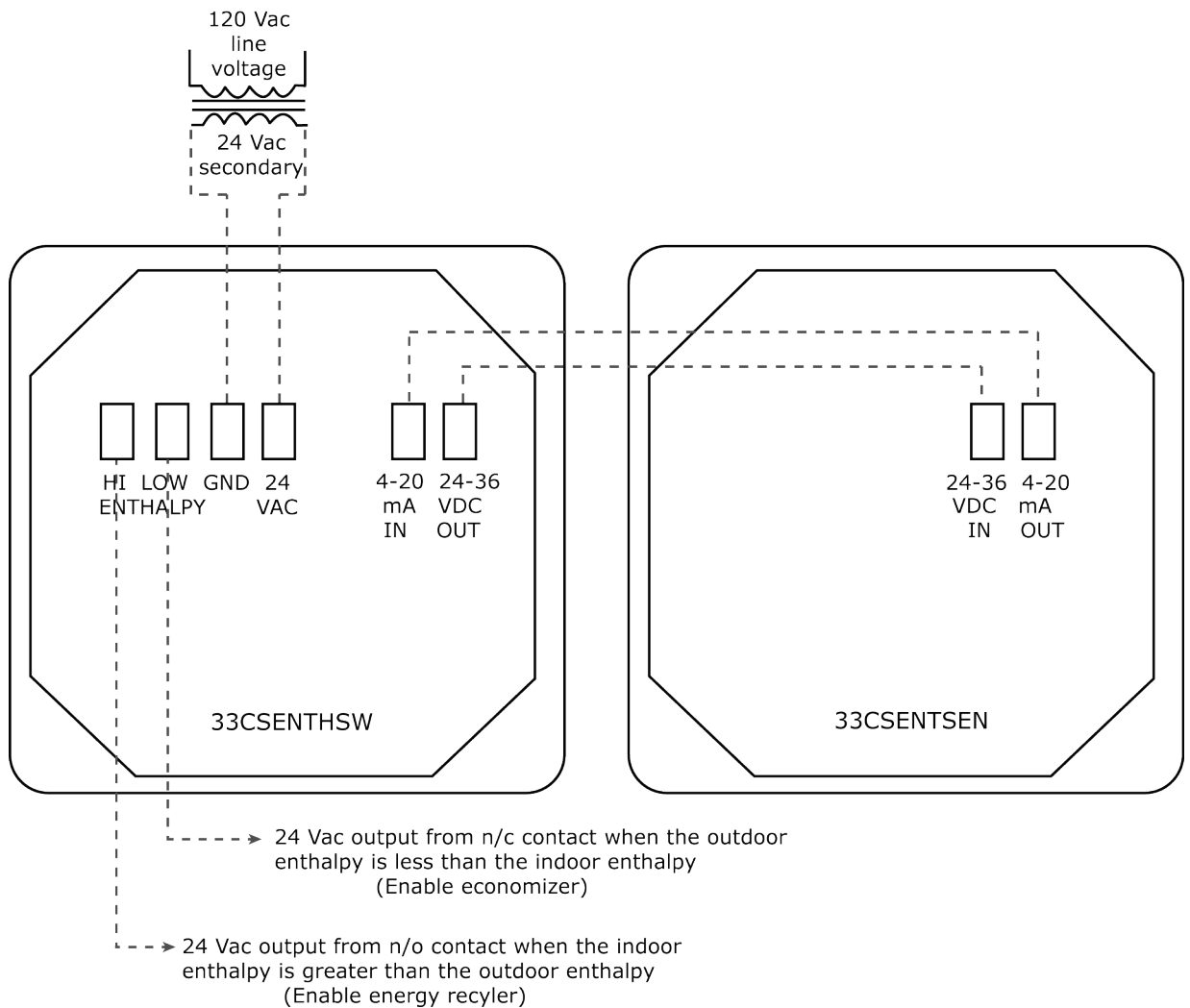

Appendix: i-Vu® Control System Wiring Specifications and Recommended Vendors

Wiring specifications		Recommended vendors & part numbers			
Wire type	Description	Connect Air International	Belden	Ramcorp	Contractors Wire & Cable
MS/TP network (RS-485)	22 AWG, single twisted shielded pair, low capacitance, CL2P, TC foam FEP, plenum rated. See MS/TP Installation Guide for specifications.	W221P-2227	--	25160PV	CLP0520LC
MS/TP network (RS-485)	24 AWG, single twisted shielded pair, low capacitance, CL2P, TC foam FEP, plenum rated. See MS/TP Installation Guide for specifications.	W241P-2000FB	82841	25120-OR	--
Rnet	4 conductor, unshielded, CMP, 18 AWG, plenum rated.	W184C-2099BLB	6302UE	21450	CLP0442
Power - 24 Vac	2 conductor, CM, 18 AWG, unshielded.	W181P-2051	5300UE	21251	CLP0440
Analog & discrete sensor wiring < 100 ft	Single twisted pair, unshielded, CM, 22AWG, plenum rated.	W221P-2005	6500UE	21281	CLP0410
Analog & discrete sensor wiring 100–500 ft	Single twisted shielded pair, CM, 22AWG, plenum rated.	W221P-2044	6500FE	21280	CLP0520

Document revision history

Important changes to this document are listed below. Minor changes such as typographical or formatting errors are not listed.

Date	Topic	Change description	Code*
3/10/16	Specifications	Added drift statement to Humidity specification.	X-TS-EE-F
5/28/15	Introduction to Carrier sensors	Carrier® ChillerVu™ added and WSHP Open removed from table	C-TS-RD-E
	ZS sensors - CO2 sensor installation	New section	C-TS-RD-E
11/24/14	Power requirements	Made corrections to wiring diagram	X-TS-JM-O
8/6/14	To address a ZS Sensor	Changed ZS Sensor default address to 1 from 0.	C-TS-RD-O
	Introduction to Carrier sensors	Added MPC Open XP controller to the table	C-D
	Entire document	BACview removed	C-D
	Introduction to Carrier Sensors	ZS Sensors added to the table	C-TS-RD-E

* For internal use only

Index

#

#33CSENTHSW • 59
 #33ZCASPCO2 • 40
 #33ZCSENDAT • 31
 #33ZCSENOAT • 34
 #33ZCSENORH-02 • 13
 #33ZCSENPAT • 28, 34, 37
 #33ZCSENSAT • 28, 37
 #33ZCSENSRH-02 • 46
 #33ZCT55CO2 • 44
 #33ZCT55SPT • 22
 #33ZCT56CO2 • 44
 #33ZCT56SPT • 22
 #33ZCT59SPT • 22
 #3CSENTSEN • 59
 #SPP • 13
 #SPPF • 13
 #SPPL • 13
 #SPS • 13

A

Alternate space temperature sensor • 22
 aspirator box • 40, 43

C

CO2 sensor • 40
 CO2/Temperature sensor • 3, 44

D

Duct Air Temperature sensor • 31
 Duct sensors
 Duct Air Temperature sensor • 31
 Enthalpy sensor • 59
 Enthalpy switch/receiver • 59
 Outdoor Air Temperature sensor • 34
 Primary Air Temperature sensor • 28, 34, 37
 Supply Air Temperature sensor • 28, 37

E

Enthalpy sensor • 59
 Enthalpy switch/receiver • 59

H

Humidity sensor • 3

O

Outdoor Air Temperature sensor • 34
 outdoor sensors
 Outdoor Air Temperature sensor • 34

P

Primary Air Temperature sensor • 28, 34, 37

R

Rnet • 13, 15, 16
 Rnet wiring specifications • 16

S

space temperature sensors • 13, 22
 SPT Plus • 13, 15, 18, 20
 SPT Pro • 13, 15, 18, 20
 SPT Pro Plus • 13, 15, 18, 20
 SPT sensors • 13
 SPT Standard • 13, 15, 20
 Supply Air Temperature sensor • 28, 37

T

T55 / T56 • 22, 44
 temperature sensors
 Alternate space temperature sensor • 22
 CO2/Temperature sensor • 3, 44
 Duct Air Temperature sensor • 31
 Outdoor Air Temperature sensor • 34
 Primary Air Temperature sensor • 28, 34, 37
 SPT sensors • 13
 Supply Air Temperature sensor • 28, 37
 ZS Sensors • 3

W

wall-mounted sensors
 CO2 sensor • 40
 CO2/Temperature sensor • 3, 44
 Wiring specifications
 Rnet • 16

Z

ZS • 3
 ZS Plus • 3
 ZS Pro • 3



CARRIER CORPORATION ©2016

A member of the United Technologies Corporation family · Stock symbol UTX · Catalog No. 11-808-423-01 · 3/10/2016