



PGD4, PGS4

Product Specifications

Up to 14.5 SEER, 12 EER, PACKAGE GAS / ELECTRIC UNIT, 2 to 5 TONS

208/230-1-60, Single Phase

208/230-3-60 & 460-3-60, Three Phase

REFRIGERATION CIRCUIT

- Environmentally sound R-410A refrigerant
- Copper tube/aluminum fin condenser and evaporator coils
- Scroll compressor standard on all models
- Dehumidification mode (airflow reduction) on all models

EASY TO INSTALL AND SERVICE

- Installs easily on a rooftop or at ground level
- Easy three-panel accessibility for maintenance and installation
- Easily converts to down discharge applications
- Combination gas heating and electric cooling
- Low NOx units available

BUILT TO LAST

- Hail guard (3/8" spacing) wire grilles standard on PGS4 single phase models (2" spacing wire grilles on PGD4 single and 3-phase models)
- Induced-draft combustion and venting
- Pre-painted steel cabinet
- Direct spark ignition
- High efficiency ECM indoor blower motor on all models
- Aluminized steel tubular heat exchanger on PGD4 models; Stainless Steel tubular heat exchanger on PGS4 models
- Vertical condenser fan discharge
- Full perimeter steel base rails
- High and low pressure switches provide added reliability for the compressor
- PGS4 single phase with tin-coated copper evaporator coil standard

LIMITED WARRANTY*

- 1 Phase PGS4 "D" Models
 - 3 year No Hassle Replacement™ limited warranty
 - 10 year parts limited warranty (including compressor and coils) with timely registration
 - 5 year parts limited warranty and 20 year heat exchanger limited warranty if not registered within 90 days of original installation.
- 1 Phase PGD4 "D" Models
 - 15 year heat exchanger limited warranty
 - 10 year parts limited warranty (including compressor and coils) with timely registration
 - 5 year parts limited warranty and 15 year heat exchanger limited warranty if not registered within 90 days of original installation.
- 3 Phase PGS4, PGD4 "D" Models
 - 10 year heat exchanger limited warranty
 - 5 year compressor limited warranty
 - 1 year parts limited warranty

* See warranty certificate for complete details and restrictions



As an Energy Star® Partner, International Comfort Products has determined that this product meets the ENERGY STAR® guidelines for energy efficiency.

Use of the AHRI Certified TM Mark indicates a manufacturer's participation in the program. For verification of certification for individual products, go to www.ahridirectory.org.

UNIT PERFORMANCE DATA									
Aluminized Steel Heat Exchanger	Stainless Steel Heat Exchanger	COOLING			HEATING			Unit Dimensions Height x Width x Depth in (mm)	Operating Weight lbs (kg)
		Capacity BTU/h	SEER	EER	Input BTU/h	Efficiency AFUE %			
						1Ø	3Ø		
PGD424040†00*D	PGS424040‡G**D	23,600	14.5	12.0	40,000	81.0	-	42 ¹ / ₈ x 48 ³ / ₁₆ x 32 ⁵ / ₈	330 (149)
PGD424060†00*D	PGS424060‡G**D	23,600	14.5	12.0	60,000	81.0	80.0	(1070 x 1224 x 829)	330 (149)
PGD430040†00*D	PGS430040‡G**D	28,600	14.5	12.0	40,000	81.0	80.0	44 ¹ / ₈ x 48 ³ / ₁₆ x 32 ⁵ / ₈	342 (155)
PGD430060†00*D	PGS430060‡G**D	28,600	14.5	12.0	60,000	81.0	80.0	(1121 x 1224 x 829)	342 (155)
PGD436060†00*D	PGS436060‡G**D	34,200	14.5	12.0	60,000	81.0	80.0	46 ¹ / ₈ x 48 ³ / ₁₆ x 32 ⁵ / ₈	376 (170)
PGD436090†00*D	PGS436090‡G**D	34,200	14.5	12.0	90,000	81.0	79.3	1172 x 1224 x 829)	376 (170)
PGD442060†00*D	PGS442060‡G**D	41,000	14.5	12.0	60,000	81.0	78.5	44 ³ / ₄ x 48 ³ / ₁₆ x 44 ¹ / ₈	463 (210)
PGD442090†00*D	PGS442090‡G**D	41,000	14.5	12.0	90,000	81.0	80.4	(1137 x 1224 x 1123)	463 (210)
PGD448090†00*D	PGS448090‡G**D	47,000	14.2	12.0	90,000	81.0	80.4	48 ³ / ₄ x 48 ³ / ₁₆ x 44 ¹ / ₈ (1238 x 1224 x 1123)	481 (218)
PGD448115†00*D	PGS448115‡G**D	47,000	14.2	12.0	115,000	81.0	80.3		481 (218)
PGD448130K00*D	PGS448130KG**D	47,000	14.2	12.0	127,000	81.0	-		481 (218)
PGD448130H00*D	PGS448130HG**D	47,000	14.2	12.0	130,000	-	78.9	481 (218)	481 (218)
PGD460090†00*D	PGS460090‡G**D	57,000	14.2	12.0	90,000	81.0	80.4	52 ³ / ₄ x 48 ³ / ₁₆ x 44 ¹ / ₈ (1368 x 1224 x 1123)	509 (231)
PGD460115†00*D	PGS460115‡G**D	57,000	14.2	12.0	115,000	81.0	80.3		509 (231)
PGD460130K00*D	PGS460130KG**D	57,000	14.2	12.0	127,000	81.0	-		509 (231)
PGD460130H00*D	PGS460130HG**D	57,000	14.2	12.0	130,000	-	78.9		509 (231)

^ - P = Tin Coated Copper Evap Main Tubes (single phase only), S = Standard Copper Evaporator Main Tubes (3-phase only)

* - 0 = Standard, 1 = Low Nox

‡ - K = 208/230-1-60, H = 208/230-3-60, L = 460-3-60

MODEL NOMENCLATURE											
MODEL SERIES	1	2	3	4	5,6	7,8,9	10	11,12	13	14	15
	P	G	D	4	36	090	K	00	0	D	1
P = Package A = Air Conditioner H = Heat Pump G = Gas/Electric D = Dual Fuel D = Standard S = Mainline w/ SS HX 3 = 13 4 = 14 5 = 15 24 = 24,000 BTUH = 2 Tons 30 = 30,000 BTUH = 2.5 Tons 36 = 36,000 BTUH = 3 Tons 42 = 42,000 BTUH = 3.5 Tons 48 = 48,000 BTUH = 4 Tons 60 = 60,000 BTUH = 5 Tons 000 = no factory heat 040 = 40,000 BTU/hr 060 = 60,000 BTU/hr 090 = 90,000 BTU/hr 115 = 115,000 BTU/hr 130 = 127,000 or 130,000 BTU/hr K = 208/230-1-60 H = 208/230-3-60 L = 460-3-60 00 = No options GP = Tin Coated Copper Evap Main Tubes plus Stainless Steel Heat Exchanger (single phase) GS = Standard Copper Evap Main Tubes plus Stainless Steel Heat Exchanger (3-phase) 0 = Standard 1 = Low NOx Sales Model Digit Engineering Digit											
TYPE											
TIER											
SEER											
NOMINAL COOLING CAPACITY											
NOMINAL HEATING BTUH (input)											
VOLTAGE											
FACTORY INSTALLED OPTIONS											
FEATURE CODE											

AHRI* CAPACITIES

Cooling Capacities and Efficiencies

UNIT SIZE	NOMINAL TONS	STANDARD CFM	COOLING CAPACITY	EER	SEER
24	2	800	23600	12.0	14.5
30	2.5	1000	28600	12.0	14.5
36	3	1200	34200	12.0	14.5
42	3.5	1400	41000	12.0	14.5
48	4	1600	47000	12.0	14.2
60	5	1750	57000	12.0	14.2

LEGEND

dB—Sound Levels (decibels)

db—Dry Bulb

SEER—Seasonal Energy Efficiency Ratio

wb—Wet Bulb

COP—Coefficient of Performance

* Air Conditioning, Heating & Refrigeration Institute.

**At "A" conditions—80°F (26.7°C) indoor db/67°F (19.4°C) indoor wb & 95°F (35°C) outdoor db.

† Rated in accordance with U.S. Government DOE Department of Energy) test procedures and/or AHRI Standards 210/240.

Notes:

1. Ratings are net values, reflecting the effects of circulating fan heat.

Ratings are based on:

Cooling Standard: 80°F (26.7°C) db, 67°F wb (19.4°C) indoor entering-air temperature and 95°F db (35°C) outdoor entering-air temperature.

2. Before purchasing this appliance, read important energy cost and efficiency information available from your retailer.

Gas Heating Capacities and Efficiencies, Single Phase Models

UNIT SIZE	HEATING INPUT (Btuh)	OUTPUT CAPACITY (Btuh)	TEMPERATURE RISE RANGE °F (°C)	AFUE (%)
24040 30040	40,000	33,000	25-55 (14-31)	81.0
24060 30060 36060 42060	60,000	49,000	25-55 (14-31)	81.0
36090 42090 48090 60090	90,000	73,000 74,000 74,000 74,000	35-65 (19-36)	81.0
48115 60115	115,000	94,000	30-60 (17-33)	81.0
48130 60130	127,000	104,000	35-65 (19-36)	81.0

LEGEND

AFUE—Annual Fuel Utilization Efficiency

NOTE: Before purchasing this appliance, read important energy cost and efficiency information available from your retailer.

Gas Heating Capacities and Efficiencies, Three Phase Models

UNIT SIZE	HEATING INPUT (Btuh)	OUTPUT CAPACITY (Btuh)	TEMPERATURE RISE RANGE °F (°C)	AFUE (%)
24040 30040	40,000	32,000	30-60 (17-33)	80.0
24060 30060 36060 42060	60,000	48,000 48,000 48,000 47,000	25-55 (14-31)	80.0 80.0 80.0 78.5
36090 42090 48090 60090	90,000	72,000 73,000 73,000 73,000	35-65 (19-36)	79.3 80.4 80.4 80.4
48115 60115	115,000	93,000	30-60 (17-33)	80.3
48130 60130	130,000	103,000	35-65 (19-36)	78.9

LEGEND

AFUE—Annual Fuel Utilization Efficiency

NOTE: Before purchasing this appliance, read important energy cost and efficiency information available from your retailer.

A-Weighted Sound Power Level (dBA)

UNIT SIZE	SOUND RATING	TYPICAL OCTAVE BAND SPECTRUM (without tone adjustment)						
		125	250	500	1000	2000	4000	8000
24	76	58.0	65.5	71.5	71.0	65.5	60.5	53.0
30	73	62.0	64.0	67.5	67.5	65.0	60.0	54.5
36	76	64.5	66.5	70.0	70.0	67.5	61.0	54.0
42	77	70.5	68.0	70.5	70.5	68.0	62.5	58.0
48	77	71.5	65.0	71.0	67.5	67.5	63.0	57.5
60	77	73.5	65.5	68.5	67.5	66.5	62.0	58.0

NOTE: Tested in accordance with AHRI Standard 270-1995 (not listed in AHRI).

PHYSICAL DATA

UNIT SIZE	24040	24060	30040	30060	36060	36090	42060	42090
NOMINAL CAPACITY (ton)	2	2	2-1/2	2-1/2	3	3	3-1/2	3-1/2
SHIPPING WEIGHT** lb.	337	337	349	349	383	383	472	472
SHIPPING WEIGHT** (kg)	153	153	158	158	174	174	214	214
COMPRESSOR / QUANTITY	Scroll / 1							
REFRIGERANT (R-410A)								
Quantity lb.	6.0	6.0	5.6	5.6	9.5	9.5	8.8	8.8
Quantity (kg)	2.7	2.7	2.5	2.5	4.3	4.3	4.0	4.0
REFRIGERANT METERING DEVICE	TXV							
OUTDOOR COIL								
Rows...Fins/in.	1..21	1..21	1..21	1..21	2..21	2..21	2..21	2..21
Face Area (sq ft)	11.9	11.9	13.6	13.6	15.4	15.4	13.6	13.6
OUTDOOR FAN								
Nominal CFM	2500	2500	2700	2700	2800	2800	3000	3000
Diameter in.	24	24	24	24	24	24	26	26
Diameter (mm)	609.6	609.6	609.6	609.6	609.6	609.6	660.4	660.4
Motor Hp (Rpm)	1/10 (810)	1/10 (810)	1/10 (810)	1/10 (810)	1/5 (810)	1/5 (810)	1/5 (810)	1/5 (810)
INDOOR COIL								
Rows...Fins/in.	3...17	3...17	3...17	3...17	3...17	3...17	3...17	3...17
Face Area (sq ft)	3.7	3.7	3.7	3.7	3.7	3.7	4.7	4.7
INDOOR BLOWER								
Nominal Cooling Airflow (Cfm)	800	800	1000	1000	1200	1200	1400	1400
Size in.	10x10	10x10	10x10	10x10	11x10	11x10	11x10	11x10
Size (mm.)	254x254	254x254	254x254	254x254	279.4x254	279.4x254	279.4x254	279.4x254
Motor HP (RPM)	1/2 (1050)	1/2 (1050)	1/2 (1050)	1/2 (1050)	3/4 (1000)	3/4 (1000)	3/4 (1075)	3/4 (1075)
FURNACE SECTION*								
Burner Orifice No. (Qty...Drill Size)								
1 Phase Natural Gas (Factory Installed)	2...44	3...44	2...44	3...44	3...44	3...38	3...44	3...38
1 Phase Propane Gas	2...55	3...55	2...55	3...55	3...55	3...53	3...55	3...53
3 Phase Natural Gas (Factory Installed)	2...44	2...38	2...44	2...38	2...38	3...38	2...38	3...38
3 Phase Propane Gas	2...55	2...53	2...55	2...53	2...53	3...53	2...53	3...53
HIGH-PRESSURE SWITCH (psig) Cut-out Reset (Auto)	650 +/- 15 420 +/- 25							
LOSS-OF-CHARGE / LOW-PRESSURE SWITCH (Liquid Line) (psig) cut-out Reset (auto)	20 +/- 5 45 +/- 10							
RETURN-AIR FILTERS†‡								
Throwaway Size in. (mm)	20x20x1 508x508x25	20x24x1 508x610x25			24x30x1 610x762x25			

UNIT SIZE	48090	48115	48130	60090	60115	60130
NOMINAL CAPACITY (ton)	4	4	4	5	5	5
SHIPPING WEIGHT** lb	490	490	490	518	518	518
SHIPPING WEIGHT** kg	222	222	222	235	235	235
COMPRESSOR / QUANTITY	Scroll / 1					
REFRIGERANT (R-410A)						
Quantity lb	9.4	9.4	9.4	12.5	12.5	12.5
Quantity (kg.)	4.3	4.3	4.3	5.7	5.7	5.7
REFRIGERANT METERING DEVICE	TXV					
OUTDOOR COIL						
Rows...Fins/in.	2...21	2...21	2...21	2...21	2...21	2...21
Face Area (sq ft)	17.5	17.5	17.5	21.4	21.4	21.4
OUTDOOR FAN						
Nominal Cfm	3200	3200	3200	3600	3600	3600
Diameter in.	26	26	26	26	26	26
Diameter (mm)	660.4	660.4	660.4	660.4	660.4	660.4
Motor Hp (Rpm)	1/5 (810)	1/5 (810)	1/5 (810)	1/5 (810)	1/5 (810)	1/5 (810)
INDOOR COIL						
Rows...Fins/in.	3...17	3...17	3...17	3...17	3...17	3...17
Face Area (sq ft)	4.7	4.7	4.7	5.7	5.7	5.7
INDOOR BLOWER						
Nominal Cooling Airflow (Cfm)	1600	1600	1600	1750	1750	1750
Size in.	11x10	11x10	11x10	11x10	11x10	11x10
Size (mm)	279.4x254	279.4x254	279.4x254	279.4x254	279.4x254	279.4x254
Motor HP (RPM)	1.0 (1075)	1.0 (1075)	1.0 (1075)	1.0 (1040)	1.0 (1040)	1.0 (1040)
FURNACE SECTION*						
Burner Orifice No. (Qty...Drill Size)						
1 & 3 Phase Natural Gas (Factory Installed)	3...38	3...33	3...31	3...38	3...33	3...31
1 & 3 Phase Propane Gas	3...53	3...51	3...49	3...53	3...51	3...49
HIGH-PRESSURE SWITCH (psig) Cut-out Reset (Auto)	650 +/- 15 420 +/- 25					
LOSS-OF-CHARGE / LOW-PRESSURE SWITCH (Liquid Line) (psig) cut-out Reset (auto)	20 +/- 5 45 +/- 10					
RETURN-AIR FILTERS †‡ in. (mm)	24x36x1 610x914x25					

*Based on altitude of 0 to 2000 ft (0-610 m).

† Required filter sizes shown are based on the larger of the AHRI (Air Conditioning Heating and Refrigeration Institute) rated cooling airflow or the heating airflow velocity of 300 ft/minute for throwaway type. Air filter pressure drop for non-standard filters must not exceed 0.08 IN. W.C.

‡ If using accessory filter rack refer to the filter rack installation instructions for correct filter sizes and quantity.

** For 460 volt units, add 14 lbs (6.35 kg) to the shipping weight.

ECONOMIZER

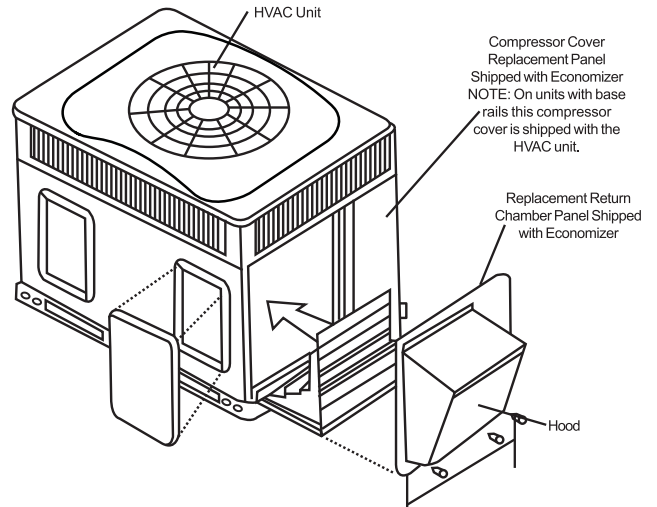
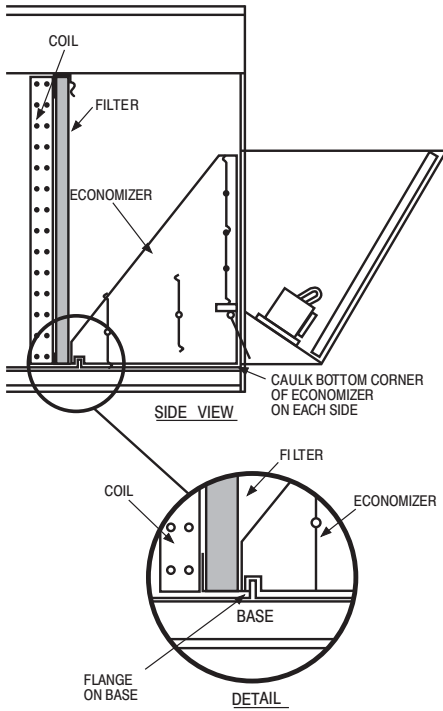

Vertical Economizer

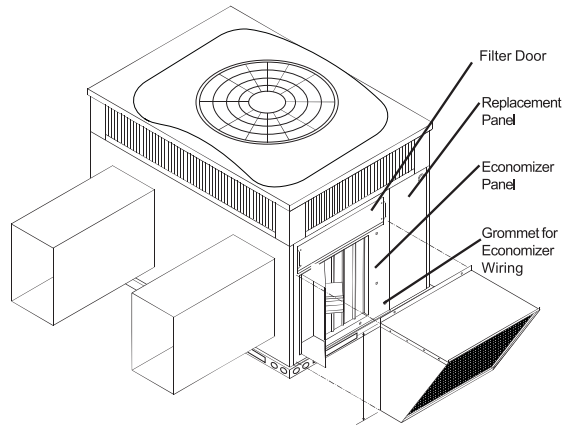

Horizontal Economizer

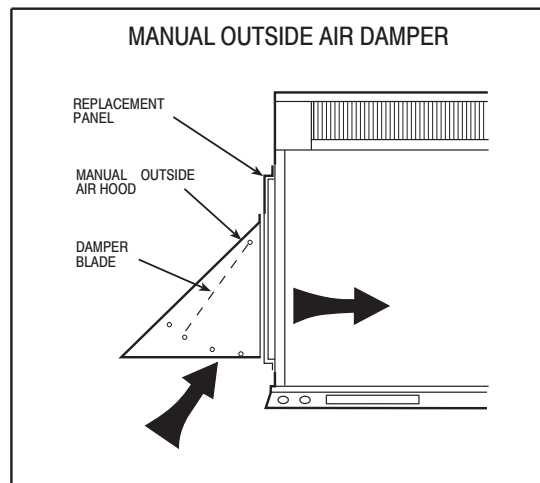
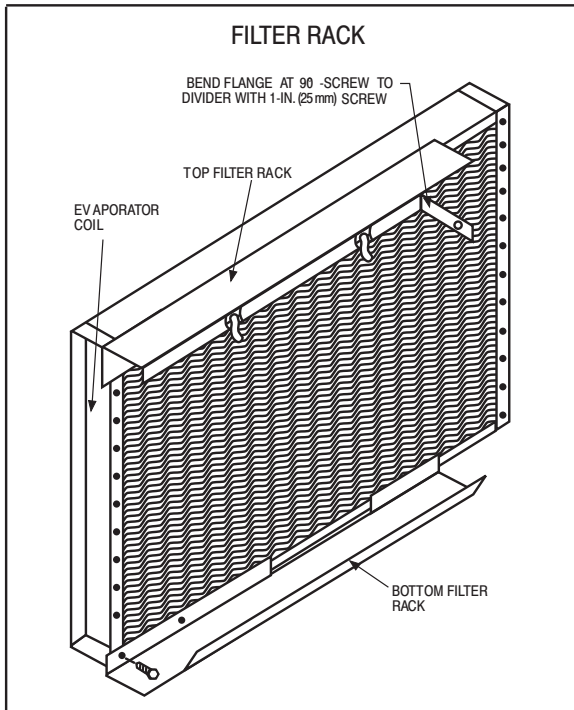

UNIT DIMENSIONS - 24-36

UNIT	ELECTRICAL CHARACTERISTICS	UNIT WT. LB. KG.	UNIT HEIGHT IN/MM			CENTER OF GRAVITY IN/MM		
			"A"	"X"	"Y"	X	Y	Z
REC0514241440/060K/00/0P/10/10/101	208/230-1-60	330 149.6	42-1/8 [1070]	22-13/16 [579.4]	15-5/16 [388.9]	15-11/16 [398.5]		
REC0514300440/060K/100/0P/10/10/101	208/230-1-208/230-3-60	342 155.0	44-1/8 [1121]	22-13/16 [579.4]	15-5/16 [388.9]	15-13/16 [401.6]		
REC0514360660/090K/100/0P/10/10/101	208/230-1, 208/230-3-60	376 170.4	46-1/8 [1172]	22-13/16 [579.4]	15-5/16 [388.9]	16-5/8 [422.3]		

UNITS	VOLTAGE	CORNER WEIGHT LB./KG.		
		"Z"	"3"	"4"
REC0514241440/060K/00/0P/10/10/101	208/230 48.5	22.5	66.0	29.9
REC0514300440/060K/100/0P/10/10/101	208/230 51.3	23.3	68.4	31.0
REC0514360660/090K/100/0P/10/10/101	208/230 58.4	25.6	75.2	34.1

REQUIRED CLEARANCES TO COMBUSTIBLE MATL.

	INCHES (MM)
TOP OF UNIT.....	14 [355.6]
DUCT SIDE OF UNIT.....	2 [50.8]
SIDE OPPOSITE DUCTS.....	14 [355.6]
DUCT OPPOSITE DUCTS.....	14 [355.6]
DUCT PANEL.....	16 [414.4]

REC. REQUIRED CLEARANCES

	INCHES (MM)
BETWEEN UNITS, POWER ENTRY SIDE.....	42 [1066.8]
UNIT AND UNGROUNDED SURFACES, POWER ENTRY SIDE.....	42 [1066.8]
UNIT AND BLOCK OR CONCRETE WALLS AND OTHER GROUNDED SURFACES, POWER ENTRY SIDE.....	42 [1066.8]

REQUIRED CLEARANCE FOR OPERATION AND SERVICE

	INCHES (MM)
EVAP. COIL ACCESS SIDE.....	36 [914.0]
EVAP. COIL REAR SIDE.....	42 [1066.8]
(EXCEPT FOR REC. REQUIREMENTS)	
UNIT TOP.....	48 [1219.2]
SIDE OPPOSITE DUCTS.....	36 [914.0]
DUCT PANEL.....	12 [304.8]

*MINIMUM DISTANCES IF UNIT IS PLACED LESS THAN 12 [304.8] FROM WALL SYSTEM, THEN SYSTEM PERFORMANCE MAY BE COMPROMISED.

NOTE:

- ALL TABLE DATA RELEVANT FOR ALL FACTORY INSTALLED OPTIONS EXCEPT ECONOMIZER.
- PICTORIALLY GRILLES MAY VARY BETWEEN MODELS.

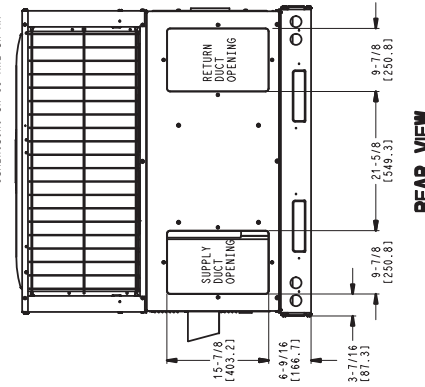
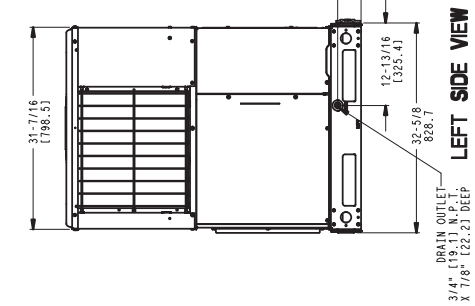
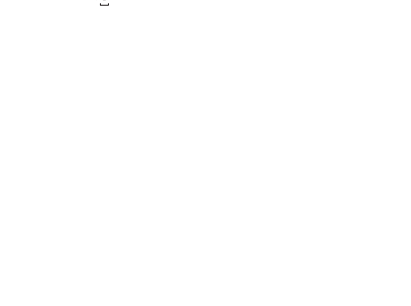
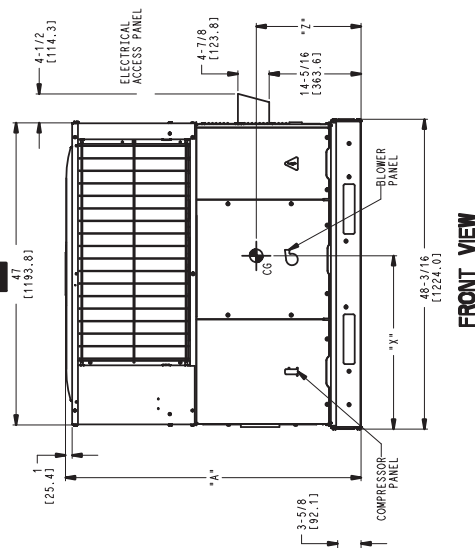
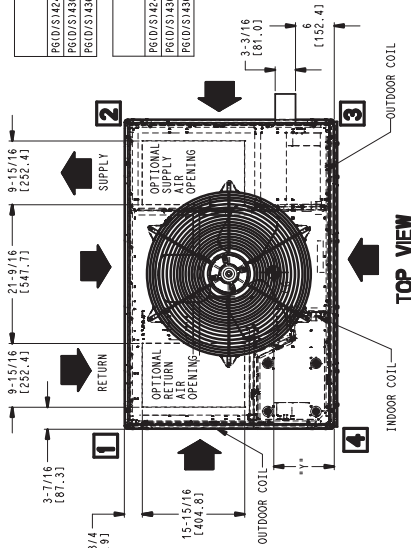

REV B
50CY502838

UNIT DIMENSIONS - 42-60

UNIT	ELECTRICAL CHARACTERISTICS	UNIT WT.			CENTER OF GRAVITY IN/MM						
		LB	KG	"A"	X	Y	Z				
FGD/S1442/080/090/K/H/100/GP/FP/10/1/D1	208/230-1, 208/230-3-60	210.1	44.3/4	1137	22-13/16	579.4	18	457.2	17-1/8	435.0	
FGD/S1448/080/115/130/K/H/100/GP/FP/10/1/D1	208/230-1, 208/230-3-60	481	218.3	48-3/4	1238	22-13/16	579.4	18	457.2	17-1/8	441.3
FGD/S1461/080/115/130/K/H/100/GP/FP/10/1/D1	208/230-1, 208/230-3-60	509	231.0	52-3/4	1340	22-13/16	579.4	18	457.2	17-1/8	447.7

UNITS	VOLTAGE	CORNER WEIGHT LB/KG							
		"1"	"2"	"4"					
FGD/S1442/080/090/K/H/100/GP/FP/10/1/D1	208/230	69.5	31.5	92.6	42.1	139.0	63.1	162.1	173.6
FGD/S1448/080/115/130/K/H/100/GP/FP/10/1/D1	208/230	72.2	32.8	96.2	43.7	144.4	65.5	168.4	176.5
FGD/S1461/080/115/130/K/H/100/GP/FP/10/1/D1	208/230	76.4	34.7	101.8	46.2	152.8	69.4	178.2	80.9

REQUIRED CLEARANCES TO COMBUSTIBLE MATL.

TOP OF UNIT.....14 (355.6)
 BETWEEN UNITS.....36 (914.4)
 SIDE OPPOSITE DIGITS.....14 (355.6)
 BOTTOM OF UNIT.....172 (4317.7)
 FLUE PANEL.....36 (914.4)

REQ. REQUIRED CLEARANCES

BETWEEN UNITS, POWER ENTRY SIDE.....42 (1066.8)
 BETWEEN UNITS, POWER ENTRY SIDE, UNIT AND BLOCK OR CONCRETE WALLS AND OTHER GROUNDED SURFACES, POWER ENTRY SIDE.....42 (1066.8)

REQUIRED CLEARANCES FOR OPERATION AND SERVICE

EVAP. COIL ACCESS SIDE.....36 (914.4)
 POWER ENTRY SIDE.....42 (1066.8)
 UNIT CLEARANCE FOR "NC REQUIREMENTS".....48 (1219.2)
 UNIT TOP OPPOSITE DIGITS.....36 (914.4)
 SIDE OPPOSITE DIGITS.....36 (914.4)
 DUCT PANEL.....12 (304.8)

*MINIMUM DISTANCES: IF UNIT IS PLACED LESS THAN 12 (304.8) FROM WALL SYSTEM, THEN SYSTEM PERFORMANCE MAYBE COMPROMISED.

DIMENSIONS IN () ARE IN MM

NOTE:
 1. ALL TABLE DATA RELEVANT FOR ALL FACTORY INSTALLED OPTIONS EXCEPT ECONOMIZER
 2. PICTORIALLY GRILLES MAY VARY BETWEEN MODELS

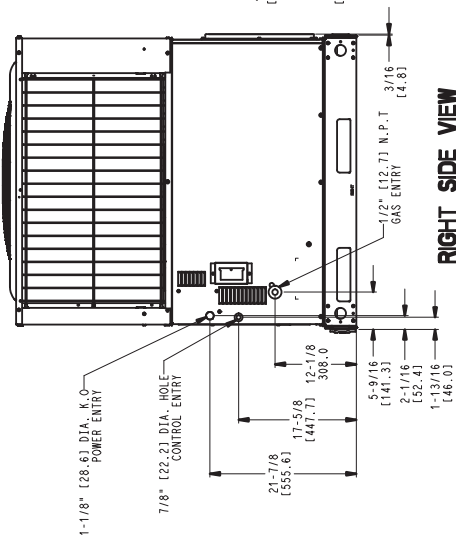
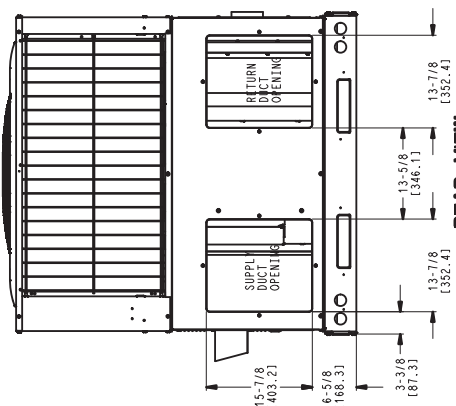
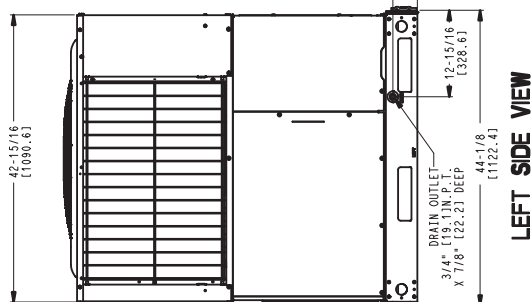
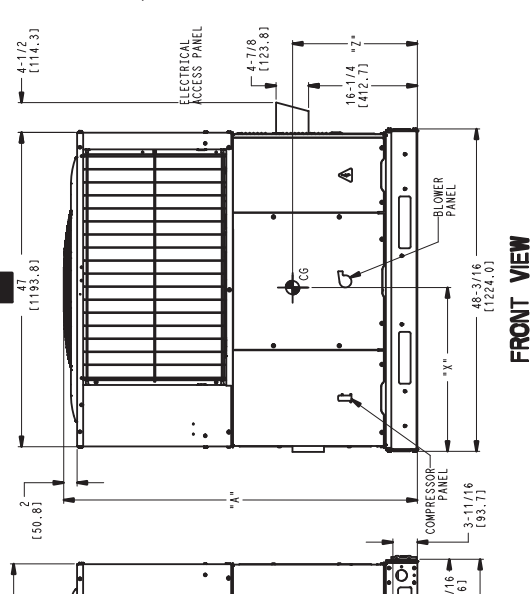
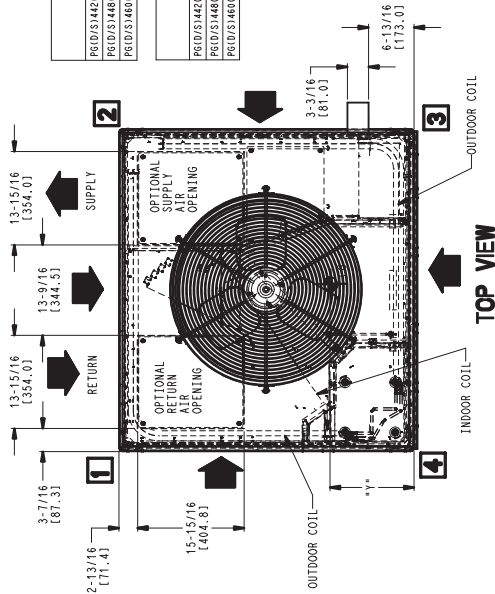

REV 50CY502839 B

ACCESSORY DIMENSIONS

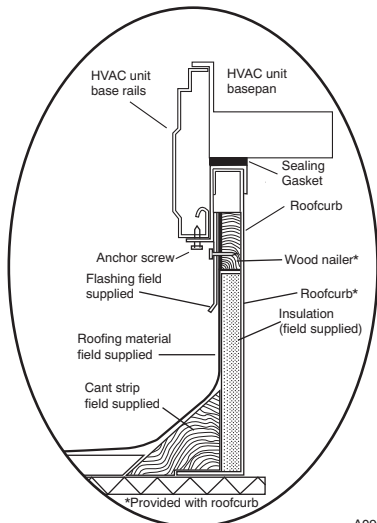

ROOF CURB DETAIL

A09090

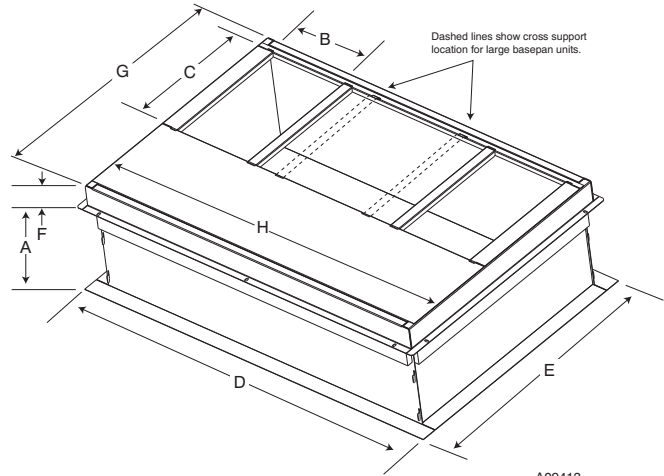

SMALL/COMMON CURB

A09413

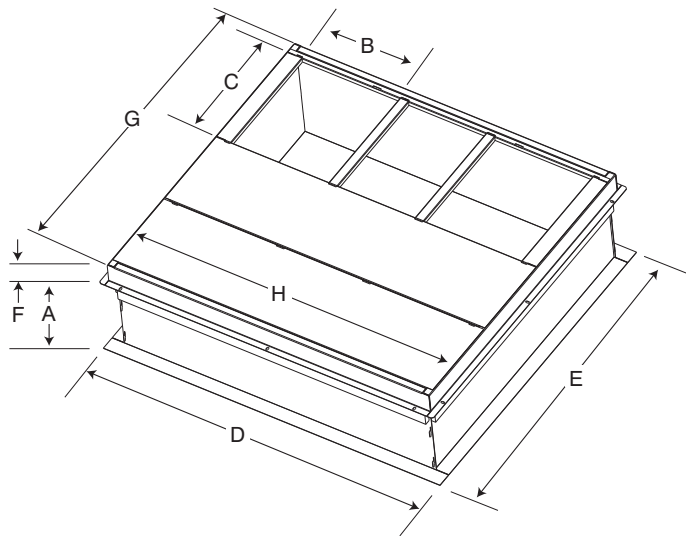

LARGE CURB

A09415

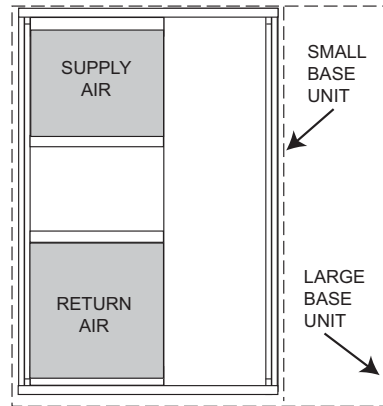

UNIT PLACEMENT ON COMMON CURB

A09094

SMALL OR LARGE BASE UNIT

A09414

UNIT SIZE	CATALOG NUMBER	A IN. (mm)	B (small / common base) IN. (mm)*	B (large base) IN. (mm)*	C IN. (mm)	D IN. (mm)	E IN. (mm)	F IN. (mm)	G IN. (mm)	H IN. (mm)
Small or Large	CPRFCURB010A00	11 (279)	10 (254)	14 (356)	16 (406)	47.8 (1214)	32.4 (822)	2.7 (69)	30.6 (778)	46.1 (1170)
	CPRFCURB011A00	14 (356)					43.9 (1116)			
Large	CPRFCURB012A00	11 (279)	14 (356)	14 (356)	16 (406)	47.8 (1214)	32.4 (822)	2.7 (69)	42.2 (1072)	46.1 (1170)
	CPRFCURB013A00	14 (356)					43.9 (1116)			

* Part Numbers CPRFCURB010A00 and CPRFCURB011A00 can be used on both small and large basepan units. The cross supports must be located based on whether the unit is a small basepan or a large basepan.

NOTES:

1. Roof curb must be set up for unit being installed.
2. Seal strip must be applied, as required, to unit being installed.
3. Roof curb is made of 16-gauge steel.
4. Attach ductwork to curb (flanges of duct rest on curb).
5. Insulated panels: 1-in. (25.4 mm) thick fiberglass 1 lb. density.

SELECTION PROCEDURE (WITH EXAMPLE)

1. Determine cooling and heating requirements at design conditions:

Given:

Required Cooling Capacity (TC) 34,000 Btuh
Sensible Heat Capacity (SHC) 25,000 Btuh
Required Heating Capacity 60,000 Btuh
Condenser Entering Air Temperature . . 95°F (35°C)
Indoor–Air Temperature 80°F (26°C)edb 67°F (19°C)ewb
Evaporator Air Quantity 1200 CFM
External Static Pressure 0.100 IN. W.C.
Electrical Characteristics 208–1–60

2. Select unit based on required cooling capacity.

Enter Net Cooling Capacities table at condenser entering temperature of 95°F (35°C). Unit 036 at 1200 cfm and 67°F (19°C) ewb (entering wet bulb) will provide a total capacity of 34,200 Btuh and a SHC of 27,400 Btuh. Calculate SHC correction, if required, using Note 4 under Cooling Capacities tables.

3. Select heating capacity of unit to provide design condition requirement.

In the Heating Capacities and Efficiencies table, note that the single phase unit 36090 will provide 73,000 Btuh with an input of 90,000 Btuh.

4. Determine fan speed and power requirements at design conditions.

Before entering the air delivery tables, calculate the total static pressure required. From the given example, the Wet Coil Pressure Drop Table, and the Filter Pressure Drop Table:

External Static Pressure	0.100 IN. W.C
Filter	0.07 IN. W.C
Wet Coil Pressure Drop	<u>0.180</u> IN. W.C
Total Static Pressure	0.287 IN. W.C

Enter the table for Dry Coil Air Delivery—Horizontal and Downflow Discharge. At .287 IN. W.C. ESP, the closest speed to 1200 CFM is Med–Low (pink wire), which delivers 1213 CFM at .3 in ESP.

5. Select unit that corresponds to power source available.

The Electrical Data Table shows that the unit is designed to operate at 208–1–60.

PERFORMANCE DATA

24 SIZE

EVAPORATOR AIR		CONDENSER ENTERING AIR TEMPERATURES °F (°C)																	
CFM/BF	EWB °F (°C)	75 (23.9)			85 (29.4)			95 (35)			105 (40.6)			115 (46.1)			125 (51.7)		
		Capacity MBtuh	Sens	Total Sys kW	Capacity MBtuh	Sens	Total Sys kW	Capacity MBtuh	Sens	Total Sys kW	Capacity MBtuh	Sens	Total Sys kW	Capacity MBtuh	Sens	Total Sys kW	Capacity MBtuh	Sens	Total Sys kW
24 Outdoor Section With NONE Indoor Section																			
	57 (13.8)	22.98	22.98	1.47	21.68	21.68	1.68	20.31	20.31	1.90	18.78	18.78	2.14	17.08	17.08	2.40	15.36	15.36	2.68
	62 (16.6)	23.82	21.37	1.48	22.23	20.56	1.68	20.58	19.70	1.91	18.81	18.81	2.14	17.11	17.11	2.40	15.39	15.39	2.68
700/0.02	63* (17.2)	24.35	17.47	1.49	22.73	16.72	1.69	21.04	15.94	1.91	19.13	15.07	2.15	16.92	14.08	2.39	14.70	13.09	2.66
	67 (19.4)	26.42	18.21	1.49	24.76	17.49	1.71	23.03	16.75	1.95	21.14	15.93	2.20	18.89	14.98	2.44	16.58	14.01	2.71
	72 (22.2)	28.85	14.79	1.50	27.32	14.23	1.72	25.63	13.61	1.96	23.80	12.93	2.23	21.65	12.14	2.52	19.22	11.24	2.79
	57 (13.8)	24.12	24.12	1.50	22.76	22.76	1.71	21.34	21.34	1.94	19.80	19.80	2.18	17.99	17.99	2.43	16.19	16.19	2.72
800/0.03	62 (16.6)	24.50	23.07	1.50	22.90	22.19	1.71	21.38	21.38	1.94	19.84	19.84	2.18	18.02	18.02	2.44	16.22	16.22	2.72
	63* (17.2)	25.00	18.69	1.50	23.32	17.92	1.72	21.58	17.12	1.94	19.66	16.24	2.18	17.37	15.21	2.42	15.09	14.18	2.69
	67 (19.4)	27.05	19.46	1.51	25.38	18.76	1.72	23.60	18.00	1.97	21.66	17.17	2.23	19.36	16.20	2.47	17.00	15.20	2.74
	72 (22.2)	29.34	15.47	1.53	27.83	14.96	1.74	26.14	14.36	1.98	24.31	13.70	2.25	22.19	12.94	2.54	19.67	12.02	2.83
	57 (13.8)	25.11	25.11	1.52	23.69	23.69	1.74	22.22	22.22	1.97	20.65	20.65	2.22	18.78	18.78	2.47	16.90	16.90	2.76
900/0.04	62 (16.6)	25.16	25.16	1.52	23.73	23.73	1.74	22.26	22.26	1.97	20.68	20.68	2.22	18.81	18.81	2.47	16.93	16.93	2.76
	63* (17.2)	25.49	19.84	1.52	23.79	19.07	1.74	22.01	18.25	1.97	20.08	17.36	2.21	17.74	16.30	2.45	15.43	15.18	2.72
	67 (19.4)	27.52	20.63	1.53	25.83	19.96	1.74	24.04	19.20	1.98	22.07	18.37	2.25	19.75	17.37	2.50	17.35	16.33	2.77
	72 (22.2)	29.68	16.09	1.55	28.19	15.62	1.76	26.50	15.05	2.00	24.67	14.41	2.27	22.61	13.70	2.57	20.03	12.76	2.86

See Legend and Notes on Page 13.

30 SIZE

EVAPORATOR AIR		CONDENSER ENTERING AIR TEMPERATURES °F (°C)																	
CFM/BF	EWB °F (°C)	75 (23.9)			85 (29.4)			95 (35)			105 (40.6)			115 (46.1)			125 (51.7)		
		Capacity MBtuh	Sens	Total Sys kW	Capacity MBtuh	Sens	Total Sys kW	Capacity MBtuh	Sens	Total Sys kW	Capacity MBtuh	Sens	Total Sys kW	Capacity MBtuh	Sens	Total Sys kW	Capacity MBtuh	Sens	Total Sys kW
30 Outdoor Section With NONE Indoor Section																			
	57 (13.8)	26.99	26.99	1.86	26.03	26.03	2.08	24.84	24.84	2.31	23.28	23.28	2.55	21.63	21.63	2.82	19.83	19.83	3.11
	62 (16.6)	27.80	26.01	1.87	26.54	25.26	2.08	25.04	24.35	2.31	23.33	23.33	2.55	21.67	21.67	2.82	19.87	19.87	3.11
875/0.03	63* (17.2)	28.37	21.21	1.87	27.09	20.50	2.09	25.54	19.70	2.32	23.41	18.68	2.55	21.13	17.63	2.81	18.66	16.51	3.08
	67 (19.4)	30.73	22.07	1.86	29.48	21.44	2.10	27.98	20.72	2.35	25.91	19.78	2.59	23.61	18.78	2.85	21.10	17.72	3.13
	72 (22.2)	33.46	17.78	1.87	32.40	17.30	2.10	31.09	16.72	2.36	29.42	16.04	2.64	27.07	15.10	2.93	24.52	14.14	3.21
	57 (13.8)	28.26	28.26	1.89	27.27	27.27	2.12	26.09	26.09	2.36	24.45	24.45	2.59	22.72	22.72	2.87	20.84	20.84	3.16
1000/0.04	62 (16.6)	28.57	27.98	1.89	27.32	27.32	2.13	26.13	26.13	2.36	24.49	24.49	2.60	22.76	22.76	2.87	20.87	20.87	3.16
	63* (17.2)	29.05	22.65	1.89	27.73	21.95	2.13	26.16	21.15	2.36	23.97	20.11	2.59	21.65	19.03	2.85	19.13	17.84	3.12
	67 (19.4)	31.37	23.54	1.89	30.12	22.95	2.12	28.60	22.25	2.38	26.53	21.33	2.63	24.15	20.29	2.89	21.60	19.20	3.18
	72 (22.2)	33.95	18.56	1.90	32.92	18.14	2.14	31.61	17.60	2.39	30.05	16.99	2.68	27.65	16.09	2.98	25.04	15.12	3.26
	57 (13.8)	29.32	29.32	1.92	28.31	28.31	2.15	27.10	27.10	2.41	25.45	25.45	2.64	23.65	23.65	2.91	21.70	21.70	3.21
1125/0.05	62 (16.6)	29.36	29.36	1.92	28.35	28.35	2.15	27.14	27.14	2.41	25.49	25.49	2.64	23.68	23.68	2.92	21.73	21.73	3.21
	63* (17.2)	29.55	24.01	1.92	28.22	23.33	2.15	26.63	22.53	2.40	24.43	21.47	2.62	22.07	20.33	2.88	19.66	19.66	3.17
	67 (19.4)	31.84	24.91	1.92	30.59	24.37	2.15	29.08	23.70	2.41	27.00	22.80	2.68	24.60	21.73	2.93	22.02	20.55	3.22
	72 (22.2)	34.29	19.27	1.94	33.28	18.91	2.17	31.97	18.40	2.43	30.44	17.85	2.71	28.11	17.06	3.01	25.43	16.05	3.31

See Legend and Notes on Page 13.

PERFORMANCE DATA (CONT)

462 11 2003 00

36 SIZE

EVAPORATOR AIR		CONDENSER ENTERING AIR TEMPERATURES °F (°C)																	
		75 (23.9)			85 (29.4)			95 (35)			105 (40.6)			115 (46.1)			125 (51.7)		
		CFM/BF	EWB °F (°C)	Capacity MBtuh		Total Sys kW	Capacity MBtuh		Total Sys kW	Capacity MBtuh		Total Sys kW	Capacity MBtuh		Total Sys kW	Capacity MBtuh		Total Sys kW	
Total	Sens			Total	Sens		Total	Sens		Total	Sens		Total	Sens					
		38 Outdoor Section With NONE Indoor Section																	
	57 (13.8)	32.04	32.04	2.19	31.05	31.05	2.46	29.67	29.67	2.74	27.89	27.89	3.04	25.97	25.97	3.38	23.86	23.86	3.76
	62 (16.6)	32.91	27.48	2.20	31.59	27.24	2.46	29.83	29.66	2.74	27.93	27.93	3.04	26.01	26.01	3.38	23.90	23.90	3.76
1050/0.04	63* (17.2)	33.62	22.38	2.21	32.24	22.10	2.47	30.40	21.63	2.75	27.88	20.90	3.04	25.18	20.09	3.37	22.23	19.16	3.72
	67 (19.4)	36.45	23.33	2.21	35.13	23.14	2.49	33.48	22.83	2.80	30.96	22.18	3.09	28.22	21.45	3.42	25.24	20.62	3.78
	72 (22.2)	39.67	18.74	2.22	38.63	18.63	2.50	37.24	18.38	2.81	35.25	17.95	3.16	32.48	17.21	3.51	29.45	16.41	3.88
	57 (13.8)	33.50	33.50	2.25	32.48	32.48	2.53	31.16	31.16	2.81	29.25	29.25	3.11	27.24	27.24	3.46	25.04	25.04	3.83
	62 (16.6)	33.79	29.49	2.25	32.53	32.53	2.53	31.22	31.22	2.82	29.30	29.30	3.11	27.28	27.28	3.46	25.08	25.08	3.84
1200/0.05	63* (17.2)	34.36	23.89	2.25	32.96	23.65	2.53	31.14	23.23	2.81	28.52	22.48	3.10	25.75	21.66	3.43	22.79	20.63	3.79
	67 (19.4)	37.19	24.89	2.25	35.85	24.76	2.54	34.20	24.50	2.85	31.64	23.89	3.16	28.84	23.16	3.49	25.80	22.30	3.85
	72 (22.2)	40.13	19.52	2.27	39.14	19.50	2.55	37.77	19.31	2.86	35.97	19.03	3.21	33.15	18.34	3.58	30.03	17.54	3.95
	57 (13.8)	34.72	34.72	2.30	33.67	33.67	2.58	32.38	32.38	2.89	30.42	30.42	3.18	28.32	28.32	3.53	26.03	26.03	3.91
	62 (16.6)	34.77	34.77	2.30	33.72	33.72	2.58	32.42	32.42	2.89	30.47	30.47	3.19	28.36	28.36	3.53	26.07	26.07	3.91
1350/0.06	63* (17.2)	34.95	25.34	2.30	33.50	25.12	2.58	31.73	24.75	2.88	29.03	23.98	3.16	26.24	23.10	3.49	23.49	23.49	3.85
	67 (19.4)	37.71	26.36	2.30	36.39	26.30	2.58	34.73	26.08	2.90	32.19	25.52	3.22	29.33	24.77	3.55	26.31	23.80	3.92
	72 (22.2)	40.41	20.21	2.32	39.47	20.28	2.60	38.09	20.14	2.91	36.46	20.02	3.26	33.65	19.42	3.64	30.47	18.63	4.02

See Legend and Notes on Page 13.

42 SIZE

EVAPORATOR AIR		CONDENSER ENTERING AIR TEMPERATURES °F (°C)																	
		75 (23.9)			85 (29.4)			95 (35)			105 (40.6)			115 (46.1)			125 (51.7)		
		CFM/BF	EWB °F (°C)	Capacity MBtuh		Total Sys kW	Capacity MBtuh		Total Sys kW	Capacity MBtuh		Total Sys kW	Capacity MBtuh		Total Sys kW	Capacity MBtuh		Total Sys kW	
Total	Sens			Total	Sens		Total	Sens		Total	Sens		Total	Sens					
		42 Outdoor Section With NONE Indoor Section																	
	57 (13.8)	39.61	39.61	2.72	37.75	37.75	3.11	35.18	35.18	3.47	32.60	32.60	3.87	29.87	29.87	4.29	27.01	27.01	4.72
	62 (16.6)	41.07	38.45	2.67	38.75	36.39	3.09	35.55	33.89	3.46	32.66	32.66	3.87	29.92	29.92	4.29	27.06	27.06	4.72
1225/0.03	63* (17.2)	41.95	31.44	2.64	39.60	29.62	3.07	36.33	27.46	3.45	32.90	25.32	3.87	29.27	23.19	4.30	25.42	21.06	4.73
	67 (19.4)	45.37	32.67	2.53	43.06	30.92	2.96	39.97	28.94	3.40	36.45	26.82	3.83	32.72	24.71	4.27	28.81	22.62	4.72
	72 (22.2)	49.27	26.39	2.42	46.93	24.87	2.85	44.47	23.37	3.31	41.33	21.77	3.74	37.56	19.92	4.23	33.52	18.06	4.71
	57 (13.8)	41.50	41.50	2.69	39.58	39.58	3.11	36.97	36.97	3.49	34.25	34.25	3.90	31.39	31.39	4.32	28.40	28.40	4.76
	62 (16.6)	42.21	41.36	2.67	39.89	39.13	3.10	37.03	37.03	3.49	34.31	34.31	3.89	31.45	31.45	4.32	28.45	28.45	4.76
1400/0.04	63* (17.2)	42.97	33.53	2.65	40.58	31.68	3.08	37.25	29.48	3.49	33.72	27.26	3.90	29.98	25.02	4.34	26.10	22.75	4.77
	67 (19.4)	46.35	34.80	2.54	43.98	33.00	2.97	41.00	31.10	3.42	37.31	28.90	3.87	33.50	26.70	4.31	29.50	24.50	4.76
	72 (22.2)	50.00	27.51	2.44	47.63	26.00	2.87	45.07	24.46	3.33	42.19	23.04	3.76	38.40	21.21	4.25	34.25	19.32	4.76
	57 (13.8)	43.07	43.07	2.68	41.12	41.12	3.10	38.51	38.51	3.52	35.67	35.67	3.92	32.70	32.70	4.36	29.59	29.59	4.80
	62 (16.6)	43.17	43.17	2.68	41.17	41.17	3.10	38.57	38.57	3.52	35.73	35.73	3.92	32.75	32.75	4.36	29.63	29.63	4.80
1575/0.05	63* (17.2)	43.75	35.51	2.67	41.32	33.62	3.10	37.99	31.40	3.52	34.37	29.08	3.94	30.58	26.74	4.37	26.77	26.77	4.81
	67 (19.4)	47.03	36.77	2.56	44.64	34.95	2.99	41.77	33.12	3.44	38.00	30.88	3.90	34.12	28.58	4.35	30.10	26.23	4.80
	72 (22.2)	50.51	28.53	2.47	48.10	27.01	2.90	45.48	25.44	3.37	42.80	24.21	3.79	39.02	22.42	4.27	34.83	20.52	4.79

See Legend and Notes on Page 13.

PERFORMANCE DATA (CONT)

48 SIZE

EVAPORATOR AIR		CONDENSER ENTERING AIR TEMPERATURES °F (°C)																	
CFM/BF	EWB °F (°C)	75 (23.9)			85 (29.4)			95 (35)			105 (40.6)			115 (46.1)			125 (51.7)		
		Capacity MBtuh	Sens	Total Sys kW	Capacity MBtuh	Sens	Total Sys kW	Capacity MBtuh	Sens	Total Sys kW	Capacity MBtuh	Sens	Total Sys kW	Capacity MBtuh	Sens	Total Sys kW	Capacity MBtuh	Sens	Total Sys kW
48 Outdoor Section With NONE Indoor Section																			
1400/0.04	57 (13.8)	45.84	45.84	2.98	43.32	43.32	3.39	40.27	40.27	3.79	36.93	36.93	4.23	33.57	33.57	4.70	30.16	30.16	5.21
	62 (16.6)	47.63	42.40	3.00	44.58	40.08	3.40	40.96	37.50	3.80	36.99	36.99	4.23	33.63	33.63	4.70	30.21	30.21	5.21
	63* (17.2)	48.63	34.72	3.00	45.52	32.68	3.41	41.85	30.46	3.82	37.52	28.03	4.23	33.20	25.66	4.69	28.77	23.31	5.18
	67 (19.4)	52.66	36.12	2.99	49.43	34.10	3.41	46.02	32.06	3.86	41.50	29.66	4.31	37.03	27.01	4.77	32.47	24.99	5.27
	72 (22.2)	57.51	29.34	2.99	54.21	27.62	3.41	50.75	25.85	3.86	46.93	24.09	4.35	42.34	22.07	4.88	37.63	20.03	5.42
1600/0.05	57 (13.8)	47.96	47.96	3.06	45.32	45.32	3.47	42.32	42.32	3.89	38.76	38.76	4.32	35.24	35.24	4.80	31.66	31.66	5.31
	62 (16.6)	48.90	45.54	3.06	45.80	43.03	3.47	42.41	42.41	3.89	38.82	38.82	4.32	35.30	35.30	4.80	31.72	31.72	5.32
	63* (17.2)	49.79	37.01	3.06	46.56	34.90	3.47	42.93	32.66	3.90	38.42	30.10	4.31	33.97	27.62	4.77	29.47	25.14	5.26
	67 (19.4)	53.81	38.48	3.05	50.48	36.40	3.46	47.00	34.30	3.92	42.43	31.88	4.39	37.88	29.44	4.86	33.20	27.00	5.35
	72 (22.2)	58.37	30.60	3.05	55.05	28.87	3.47	51.47	27.05	3.93	47.81	25.40	4.41	43.22	23.43	4.94	38.39	21.38	5.50
1800/0.06	57 (13.8)	49.74	49.74	3.12	47.00	47.00	3.53	44.06	44.06	3.98	40.29	40.29	4.41	36.64	36.64	4.89	32.92	32.92	5.41
	62 (16.6)	50.02	49.61	3.11	47.06	47.06	3.53	44.13	44.13	3.98	40.35	40.35	4.41	36.69	36.69	4.89	32.97	32.97	5.41
	63* (17.2)	50.68	39.21	3.11	47.38	37.03	3.53	43.79	34.77	3.98	39.13	32.09	4.38	34.61	29.48	4.84	30.08	26.75	5.33
	67 (19.4)	54.66	40.72	3.10	51.27	38.58	3.52	47.75	36.43	3.97	43.18	34.03	4.47	38.53	31.47	4.93	33.83	28.88	5.44
	72 (22.2)	58.98	31.74	3.11	55.61	30.01	3.53	51.97	28.16	3.99	48.35	26.51	4.48	43.87	24.71	4.99	38.98	22.66	5.56

See Legend and Notes on Page 13.

60 SIZE

EVAPORATOR AIR		CONDENSER ENTERING AIR TEMPERATURES °F (°C)																	
CFM/BF	EWB °F (°C)	75 (23.9)			85 (29.4)			95 (35)			105 (40.6)			115 (46.1)			125 (51.7)		
		Capacity MBtuh	Sens	Total Sys kW	Capacity MBtuh	Sens	Total Sys kW	Capacity MBtuh	Sens	Total Sys kW	Capacity MBtuh	Sens	Total Sys kW	Capacity MBtuh	Sens	Total Sys kW	Capacity MBtuh	Sens	Total Sys kW
1750/0.19	57 (13.8)	57.97	57.97	3.80	55.02	55.02	4.21	51.93	51.93	4.68	48.68	48.68	5.21	45.23	45.23	5.81	41.56	41.56	6.49
	62 (16.6)	59.45	53.94	3.82	55.93	51.73	4.22	52.32	49.43	4.68	48.74	48.74	5.21	45.29	45.29	5.81	41.61	41.61	6.49
	63* (17.2)	60.48	43.88	3.83	56.84	41.90	4.23	53.09	39.89	4.69	49.17	37.85	5.21	45.08	35.75	5.80	40.81	33.61	6.47
	67 (19.4)	65.05	45.58	3.88	61.08	43.55	4.29	57.00	41.50	4.75	52.75	39.41	5.27	48.31	37.28	5.86	43.70	35.10	6.52
	72 (22.2)	71.36	36.96	3.97	66.97	35.08	4.38	62.43	33.17	4.83	57.72	31.22	5.35	52.82	29.25	5.94	47.74	27.24	6.59
2000/0.23	57 (13.8)	60.36	60.36	3.91	57.19	57.19	4.32	53.88	53.88	4.79	50.41	50.41	5.31	46.72	46.72	5.91	42.83	42.83	6.59
	62 (16.6)	60.82	57.92	3.91	57.29	57.29	4.32	53.96	53.96	4.79	50.47	50.47	5.32	46.78	46.78	5.92	42.88	42.88	6.59
	63* (17.2)	61.65	46.80	3.92	57.84	44.73	4.33	53.93	42.64	4.78	49.88	40.51	5.30	45.65	38.32	5.89	41.27	36.06	6.56
	67 (19.4)	66.24	48.72	3.98	62.11	46.60	4.39	57.86	44.46	4.85	53.47	42.28	5.36	48.88	40.05	5.95	44.14	37.77	6.61
	72 (22.2)	72.62	38.94	4.06	68.04	36.99	4.47	63.32	35.02	4.93	58.45	33.03	5.45	53.38	30.99	6.03	48.15	28.93	6.68
2250/0.27	57 (13.8)	62.35	62.35	4.01	58.99	58.99	4.43	55.49	55.49	4.89	51.82	51.82	5.42	47.93	47.93	6.02	43.84	43.84	6.69
	62 (16.6)	62.44	62.44	4.01	59.07	59.07	4.43	55.56	55.56	4.89	51.88	51.88	5.42	47.99	47.99	6.02	43.88	43.88	6.69
	63* (17.2)	62.51	49.60	4.01	58.59	47.45	4.42	54.57	45.27	4.87	50.40	43.04	5.39	46.08	40.74	5.98	41.62	38.30	6.65
	67 (19.4)	67.13	51.74	4.07	62.86	49.53	4.48	58.50	47.31	4.94	53.98	45.03	5.46	49.29	42.69	6.04	44.47	40.24	6.70
	72 (22.2)	73.55	40.84	4.16	68.82	38.84	4.57	63.97	36.82	5.02	58.95	34.76	5.54	53.76	32.68	6.12	48.40	30.58	6.77

See Legend and Notes on Page 13.

PERFORMANCE DATA (CONT)

* At 75°F (24°C) entering dry bulb—Tennessee Valley Authority (TVA) rating conditions; all others at 80°F dry bulb.

LEGEND

BF— Bypass Factor
edb— Entering Dry-Bulb
Ewb— Entering Wet-Bulb
kW — Total Unit Power Input
SHC— Sensible Heat Capacity (1000 Btuh)
TC — Total Capacity (1000 Btuh) (net)
rh—Relative Humidity

COOLING NOTES:

1. Ratings are net; they account for the effects of the evaporator-fan motor power and heat.
2. Direct interpolation is permissible. Do not extrapolate.
3. The following formulas may be used:

$$t_{db} = t_{edb} - \frac{\text{Sensible capacity (Btuh)}}{1.10 \times \text{cfm}}$$

$$t_{wb} = \text{Wet-bulb temperature corresponding to enthalpy air leaving evaporator coil } (t_{lwb})$$

$$h_{lwb} = h_{ewb} - \frac{\text{total capacity (Btuh)}}{4.5 \times \text{cfm}}$$

Where: h_{ewb} = Enthalpy of air entering evaporator coil

4. The SHC is based on 80°F (26.6°C) edb temperature of air entering evaporator coil. Below 80°F (26.6°C) edb, subtract (corr factor x cfm) from SHC.

Above 80°F (26.6°C) edb, add (corr factor x cfm) to SHC.

5. Integrated capacity is maximum (instantaneous) capacity less the effect of frost on the outdoor coil and the heat required to defrost it.

PERFORMANCE DATA (CONT)

GAS ADJUSTMENT

Natural Gas Orifice Sizes and Manifold Pressure – Single Phase Models

Nameplate Input (Btu/hr)		ALTITUDE OF INSTALLATION (FT. ABOVE SEA LEVEL) U.S.A.*				
		0 to 2000 (0–610 m)	2001 to 3000* (611 to 914 m)	3001 to 4000 (915 to 1219 m)	4001 to 5000 (1220 to 1524 m)	5001 to 6000 (1524 to 1829 m)
40000	Orifice No. (Qty)	44 (2)	45 (2)†	48 (2)†	48 (2)†	48 (2)†
	Manifold Press. (in. W.C.)	3.2	3.2	3.8	3.5	3.2
60000	Orifice No. (Qty)	44 (3)	45 (3)†	48 (3)†	48 (3)†	48 (3)†
	Manifold Press. (in. W.C.)	3.2	3.2	3.8	3.5	3.2
90000	Orifice No. (Qty)	38 (3)	41 (3)†	41 (3)†	42 (3)†	42 (3)†
	Manifold Press. (in. W.C.)	3.6	3.8	3.4	3.4	3.2
115000	Orifice No. (Qty)	33 (3)	36 (3)†	36 (3)†	36 (3)†	38 (3)†
	Manifold Press. (in. W.C.)	3.8	3.8	3.6	3.3	3.6
127000	Orifice No. (Qty)	31 (3)	31 (3)	33 (3)†	33 (3)†	34 (3)†
	Manifold Press. (in. W.C.)	3.7	3.2	3.5	3.2	3.2

*In the U.S.A., the input rating for altitudes above 2000 ft (610m) must be reduced by 4% for each 1000 ft (305 m) above sea level.

In Canada, the input rating for altitudes from 2001 to 4500 ft (611 to 1372 m) above sea level must be derated by 10% by an authorized gas conversion station or dealer. For Canadian Installations from 2000 to 4500 ft, use U.S.A. column 2001 to 3000 ft.

Note: Orifice sizes and manifold pressure settings are based on natural gas with a heating value of 1025 Btu/ft³ and a specific gravity of .6.

† Orifices available through your distributor.

Natural Gas Orifice Sizes and Manifold Pressure – Three Phase Models

Nameplate Input (Btu/hr)		ALTITUDE OF INSTALLATION (FT. ABOVE SEA LEVEL) U.S.A.*				
		0 to 2000 (0–610 m)	2001 to 3000* (611 to 914 m)	3001 to 4000 (915 to 1219 m)	4001 to 5000 (1220 to 1524 m)	5001 to 6000 (1524 to 1829 m)
40000	Orifice No. (Qty)	44 (2)	45 (2)†	48 (2)†	48 (2)†	48 (2)†
	Manifold Press. (in. W.C.)	3.2	3.2	3.8	3.5	3.2
60000	Orifice No. (Qty)	38 (2)	41 (2)†	41 (2)†	42 (2)†	42 (2)†
	Manifold Press. (in. W.C.)	3.6	3.8	3.4	3.4	3.2
90000	Orifice No. (Qty)	38 (3)	41 (3)†	41 (3)†	42 (3)†	42 (3)†
	Manifold Press. (in. W.C.)	3.6	3.8	3.4	3.4	3.2
115000	Orifice No. (Qty)	33 (3)	36 (3)†	36 (3)†	36 (3)†	38 (3)†
	Manifold Press. (in. W.C.)	3.8	3.8	3.6	3.3	3.6
130000	Orifice No. (Qty)	31 (3)	31 (3)	33 (3)†	33 (3)†	34 (3)†
	Manifold Press. (in. W.C.)	3.8	3.2	3.7	3.4	3.3

*In the U.S.A., the input rating for altitudes above 2000 ft (610m) must be reduced by 4% for each 1000 ft (305 m) above sea level.

In Canada, the input rating for altitudes from 2001 to 4500 ft (611 to 1372 m) above sea level must be derated by 10% by an authorized gas conversion station or dealer. For Canadian Installations from 2000 to 4500 ft, use U.S.A. column 2001 to 3000 ft.

Note: Orifice sizes and manifold pressure settings are based on natural gas with a heating value of 1025 Btu/ft³ and a specific gravity of .6.

† Orifices available through your distributor.

Propane Gas Orifice Sizes and Manifold Pressure – Single Phase Models

Nameplate Input (Btu/hr)		ALTITUDE OF INSTALLATION (FT. ABOVE SEA LEVEL) U.S.A.*				
		0 to 2000 (0–610 m)	2001 to 3000* (611 to 914 m)	3001 to 4000 (915 to 1219 m)	4001 to 5000 (1220 to 1524 m)	5001 to 6000 (1524 to 1829 m)
40000	Orifice No. (Qty)	55 (2)	56 (2)	56 (2)	56 (2)	56 (2)
	Manifold Press. (in. W.C.)	10.0	11.0	11.0	11.0	10.7
60000	Orifice No. (Qty)	55 (3)	56 (3)	56 (3)	56 (3)	56 (3)
	Manifold Press. (in. W.C.)	10.0	11.0	11.0	11.0	10.7
90000	Orifice No. (Qty)	53 (3)	54 (3)	54 (3)	54 (3)	54 (3)
	Manifold Press. (in. W.C.)	10.0	11.0	11.0	11.0	11.0
115000	Orifice No. (Qty)	51 (3)	52 (3)	52 (3)	53 (3)	53 (3)
	Manifold Press. (in. W.C.)	10.0	11.0	10.6	11.0	11.0
127000	Orifice No. (Qty)	49 (3)	50 (3)	51 (3)	52 (3)	52 (3)
	Manifold Press. (in. W.C.)	10.0	11.0	11.0	11.0	11.0

*In the U.S.A., the input rating for altitudes above 2000 ft (610m) must be reduced by 4% for each 1000 ft (305 m) above sea level.

In Canada, the input rating for altitudes from 2001 to 4500 ft (611 to 1372 m) above sea level must be derated by 10% by an authorized gas conversion station or dealer. For Canadian Installations from 2000 to 4500 ft (610–1372 m), use U.S.A. column 2001 to 3000 ft (611 to 914 m).

† Use Kit No. CPLPCONV013C00 (0–2000 ft [0–610 m] above sea level). Use Kit No. CPLPCONV014C00 (2001–6000 ft [611–1829 m] above sea level).

Propane Gas Orifice Sizes and Manifold Pressure – Three Phase Models

Nameplate Input (Btu/hr)		ALTITUDE OF INSTALLATION (FT. ABOVE SEA LEVEL) U.S.A.*				
		0 to 2000 (0–610 m)	2001 to 3000* (611 to 914 m)	3001 to 4000 (915 to 1219 m)	4001 to 5000 (1220 to 1524 m)	5001 to 6000 (1524 to 1829 m)
40000	Orifice No. (Qty)	55 (2)	56 (2)	56 (2)	56 (2)	56 (2)
	Manifold Press. (in. W.C.)	10.0	11.0	11.0	11.0	10.7
60000	Orifice No. (Qty)	53 (2)	54 (2)	54 (2)	54 (2)	54 (2)
	Manifold Press. (in. W.C.)	10.0	11.0	11.0	11.0	11.0
90000	Orifice No. (Qty)	53 (3)	54 (3)	54 (3)	54 (3)	54 (3)
	Manifold Press. (in. W.C.)	10.0	11.0	11.0	11.0	11.0
115000	Orifice No. (Qty)	51 (3)	52 (3)	52 (3)	53 (3)	53 (3)
	Manifold Press. (in. W.C.)	10.0	11.0	10.6	11.0	11.0
130000	Orifice No. (Qty)	49 (3)	50 (3)	51 (3)	52 (3)	52 (3)
	Manifold Press. (in. W.C.)	10.0	11.0	11.0	11.0	11.0

*In the U.S.A., the input rating for altitudes above 2000 ft (610m) must be reduced by 4% for each 1000 ft (305 m) above sea level.

In Canada, the input rating for altitudes from 2001 to 4500 ft (611 to 1372 m) above sea level must be derated by 10% by an authorized gas conversion station or dealer. For Canadian Installations from 2000 to 4500 ft (610–1372 m), use U.S.A. column 2001 to 3000 ft (611 to 914 m).

†Use Kit No. CPLPCONV013*00 (0–2000 ft [0–610 m] above sea level). Use Kit No. CPLPCONV014*00 (2001–6000 ft [611–1829 m] above sea level).

High Altitude Compensation, Propane Gas – Single Phase Models

Nameplate Input (Btu/hr)	Rated Heating Input (Btu/hr), LP Gas at Installation Altitude Above Sea Level, U.S.A.*				
	0 to 2000 ft (0–610 m)	2001 to 3000 ft* (611 to 914 m)	3001 to 4000 ft (915 to 1219 m)	4001 to 5000 ft (1220 to 1524 m)	5001 to 6000 ft (1524 to 1829 m)
40000	38000	31700	31700	31700	31200
60000	57000	47500	47500	47500	46900
90000	79000	68900	68900	68600	68600
115000	103000	100400	98900	83000	83000
127000	116000	115500	111800	101300	100400

*In the U.S.A., the input rating for altitudes above 2000 ft (610m) must be reduced by 4% for each 1000 ft (305 m) above sea level.

In Canada, the input rating for altitudes from 2001 to 4500 ft (611 to 1372 m) above sea level must be derated by 10% by an authorized gas conversion station or dealer. For Canadian Installations from 2000 to 4500 ft (610–1372 m), use U.S.A. column 2001 to 3000 ft (611 to 914 m).

High Altitude Compensation, Propane Gas – Three Phase Models

Nameplate Input (Btu/hr)	Rated Heating Input (Btu/hr), LP Gas at Installation Altitude Above Sea Level, U.S.A.*				
	0 to 2000 ft (0–610 m)	2001 to 3000 ft* (611 to 914 m)	3001 to 4000 ft (915 to 1219 m)	4001 to 5000 ft (1220 to 1524 m)	5001 to 6000 ft (1524 to 1829 m)
40000	38000	31700	31700	31700	31200
60000	53000	45900	45900	45800	45800
90000	79000	68900	68900	68600	68600
115000	103000	100400	98900	83000	83000
130000	116000	115500	111800	101300	100400

*In the U.S.A., the input rating for altitudes above 2000 ft (610m) must be reduced by 4% for each 1000 ft (305 m) above sea level.

In Canada, the input rating for altitudes from 2001 to 4500 ft (611 to 1372 m) above sea level must be derated by 10% by an authorized gas conversion station or dealer. For Canadian Installations from 2000 to 4500 ft (610–1372 m), use U.S.A. column 2001 to 3000 ft (611 to 914 m).

High Altitude Compensation, Natural Gas – Single Phase Models

Nameplate Input (Btu/hr)	Rated Heating Input (Btu/hr), Natural Gas at Installation Altitude Above Sea Level, U.S.A.*				
	0 to 2000 ft (0–610 m)	2001 to 3000 ft* (611 to 914 m)	3001 to 4000 ft (915 to 1219 m)	4001 to 5000 ft (1220 to 1524 m)	5001 to 6000 ft (1524 to 1829 m)
40000	40000	36000	34400	32800	31200
60000	60000	54000	51600	49200	46800
90000	90000	81000	77400	73800	70200
115000	115000	103500	98900	94300	89700
127000	127000	114300	109200	104100	99100

*In the U.S.A., the input rating for altitudes above 2000 ft (610m) must be reduced by 4% for each 1000 ft (305 m) above sea level.

In Canada, the input rating for altitudes from 2001 to 4500 ft (611 to 1372 m) above sea level must be derated by 10% by an authorized gas conversion station or dealer. For Canadian Installations from 2000 to 4500 ft (610–1372 m), use U.S.A. column 2001 to 3000 ft (611 to 914 m).

High Altitude Compensation, Natural Gas – Three Phase Models

Nameplate Input (Btu/hr)	Rated Heating Input (Btu/hr), Natural Gas at Installation Altitude Above Sea Level, U.S.A.*				
	0 to 2000 ft (0–610 m)	2001 to 3000 ft* (611 to 914 m)	3001 to 4000 ft (915 to 1219 m)	4001 to 5000 ft (1220 to 1524 m)	5001 to 6000 ft (1524 to 1829 m)
40000	40000	36000	34400	32800	31200
60000	60000	54000	51600	49200	46800
90000	90000	81000	77400	73800	70200
115000	115000	103500	98900	94300	89700
130000	130000	117000	111800	106600	101400

*In the U.S.A., the input rating for altitudes above 2000 ft (610m) must be reduced by 4% for each 1000 ft (305 m) above sea level.

In Canada, the input rating for altitudes from 2001 to 4500 ft (611 to 1372 m) above sea level must be derated by 10% by an authorized gas conversion station or dealer. For Canadian Installations from 2000 to 4500 ft (610–1372 m), use U.S.A. column 2001 to 3000 ft (611 to 914 m).

Dry Coil Air Delivery* – Horizontal and Downflow Discharge Unit 24–60 208/230VAC – 1 Phase

Unit Size	Heating Rise Range °F (°C)	Motor Speed	Wire Color	External Static Pressure (IN. W.C.)																
				0.1	0.2	0.3	0.4	0.5	0.6	0.7	0.8	0.9	1							
24040	25 - 55 (14 - 31)	Low ¹	Blue	CFM	774	700	623	546	439	339	---	---	---	---	---	---				
				BHP	0.12	0.13	0.13	0.14	0.14	0.15	---	---	---	---	---	---	---			
				Heat Rise (°F)	39	43	48	55	NA	NA	NA	NA	NA	NA	NA	NA	NA	NA		
				Heat Rise (°C)	21	24	27	30	NA	NA	NA	NA	NA	NA	NA	NA	NA	NA	NA	
				CFM	804	734	659	574	482	387	---	---	---	---	---	---	---	---		
				BHP	0.13	0.14	0.14	0.15	0.15	0.16	---	---	---	---	---	---	---	---		
		Med-Low ³	Pink	Medium ²	Red	Heat Rise (°F)	37	41	45	52	NA	NA	NA	NA	NA	NA	NA	NA		
						Heat Rise (°C)	21	23	25	29	NA	NA	NA	NA	NA	NA	NA	NA	NA	
						CFM	842	787	715	641	556	461	382	---	---	---	---	---	---	
						BHP	0.15	0.16	0.16	0.17	0.17	0.18	0.19	---	---	---	---	---	---	
						Heat Rise (°F)	36	38	42	47	54	NA	NA	NA	NA	NA	NA	NA	NA	NA
						Heat Rise (°C)	20	21	23	26	30	NA	NA	NA	NA	NA	NA	NA	NA	NA
24060	25 - 55 (14 - 31)	Med-High	Orange	CFM	920	868	803	738	654	570	491	404	---	---	---	---				
				BHP	0.18	0.19	0.19	0.20	0.21	0.21	0.22	0.23	---	---	---	---				
				Heat Rise (°F)	33	35	37	41	46	53	NA	NA	NA	NA	NA	NA	NA			
				Heat Rise (°C)	18	19	21	23	25	29	NA	NA	NA	NA	NA	NA	NA			
				CFM	1125	1075	1019	956	891	825	760	695	594	491	---	---	---			
				BHP	0.30	0.31	0.32	0.32	0.33	0.34	0.34	0.35	0.35	0.34	---	---	---			
		High	Black	High	Black	Heat Rise (°F)	27	28	29	31	34	36	39	43	50	NA	NA	NA		
						Heat Rise (°C)	15	15	16	17	19	20	22	24	28	NA	NA	NA		
						CFM	774	700	623	546	439	339	---	---	---	---	---	---	---	
						BHP	0.12	0.13	0.13	0.14	0.14	0.15	---	---	---	---	---	---	---	
						Heat Rise (°F)	NA	NA	NA	NA	NA	NA	NA	NA	NA	NA	NA	NA	NA	
						Heat Rise (°C)	NA	NA	NA	NA	NA	NA	NA	NA	NA	NA	NA	NA	NA	
24060	25 - 55 (14 - 31)	Med-Low	Pink	CFM	804	734	659	574	482	387	---	---	---	---	---					
				BHP	0.13	0.14	0.14	0.15	0.15	0.16	---	---	---	---	---	---				
				Heat Rise (°F)	NA	NA	NA	NA	NA	NA	NA	NA	NA	NA	NA	NA	NA			
				Heat Rise (°C)	NA	NA	NA	NA	NA	NA	NA	NA	NA	NA	NA	NA	NA			
				CFM	842	787	715	641	556	461	382	---	---	---	---	---				
				BHP	0.15	0.16	0.16	0.17	0.17	0.18	0.19	---	---	---	---	---				
		Med-High	Orange	Med-High	Orange	Heat Rise (°F)	53	NA	NA	NA	NA	NA	NA	NA	NA	NA	NA	NA		
						Heat Rise (°C)	30	NA	NA	NA	NA	NA	NA	NA	NA	NA	NA	NA		
						CFM	920	868	803	738	654	570	491	404	---	---	---	---		
						BHP	0.18	0.19	0.19	0.20	0.21	0.21	0.22	0.23	---	---	---	---		
						Heat Rise (°F)	49	52	NA	NA	NA	NA	NA	NA	NA	NA	NA	NA		
						Heat Rise (°C)	27	29	NA	NA	NA	NA	NA	NA	NA	NA	NA	NA		
High ¹	Black	High ¹	Black	CFM	1125	1075	1019	956	891	825	760	695	594	491	---					
				BHP	0.30	0.31	0.32	0.32	0.33	0.34	0.34	0.35	0.35	0.34	---	---				
				Heat Rise (°F)	40	42	44	47	51	55	NA	NA	NA	NA	NA	NA				
				Heat Rise (°C)	22	23	25	26	28	30	NA	NA	NA	NA	NA	NA				
				CFM	1125	1075	1019	956	891	825	760	695	594	491	---	---				
				BHP	0.30	0.31	0.32	0.32	0.33	0.34	0.34	0.35	0.35	0.34	---	---				

Dry Coil Air Delivery* – Horizontal and Downflow Discharge Unit 24–60 208/230VAC – 1 Phase (Cont.)

Unit Size	Heating Rise Range °F (°C)	Motor Speed	Wire Color	External Static Pressure (IN. W.C.)													
				0.1	0.2	0.3	0.4	0.5	0.6	0.7	0.8	0.9	1				
30040	25 - 55 (14 - 31)	Low ¹	Blue	CFM	774	700	623	546	439	339	---	---	---	---	---	---	
				BHP	0.12	0.13	0.13	0.14	0.14	0.15	---	---	---	---	---	---	
				Heat Rise (°F)	39	43	48	55	NA	NA	NA	NA	NA	NA	NA	NA	NA
				Heat Rise (°C)	21	24	27	30	NA	NA	NA	NA	NA	NA	NA	NA	NA
				CFM	906	843	771	707	624	548	451	340	---	---	---	---	---
				BHP	0.18	0.18	0.19	0.20	0.20	0.21	0.21	0.22	---	---	---	---	---
		Med-Low ³	Pink	Heat Rise (°F)	33	36	39	42	48	55	NA	NA	NA	NA	NA	NA	
				Heat Rise (°C)	18	20	22	24	27	30	NA	NA	NA	NA	NA	NA	
				CFM	1008	942	872	804	734	647	546	510	399	---	---	---	
				BHP	0.22	0.23	0.24	0.24	0.24	0.26	0.26	0.27	0.27	0.27	0.27	0.27	
				Heat Rise (°F)	30	32	34	37	41	46	55	NA	NA	NA	NA	NA	
				Heat Rise (°C)	17	18	19	21	23	26	30	NA	NA	NA	NA	NA	
30060	25 - 55 (14 - 31)	Med-High ²	Orange	CFM	1047	997	931	875	804	737	676	584	494	401			
				BHP	0.25	0.26	0.26	0.27	0.28	0.28	0.29	0.30	0.30	0.31	0.31		
				Heat Rise (°F)	29	30	32	34	37	41	44	51	NA	NA	NA		
				Heat Rise (°C)	16	17	18	19	21	23	25	28	NA	NA	NA		
				CFM	1125	1075	1019	956	891	825	760	695	594	491	401		
				BHP	0.30	0.31	0.32	0.32	0.33	0.34	0.34	0.35	0.35	0.35	0.34		
		High	Black	Heat Rise (°F)	27	28	29	31	34	36	39	43	50	NA	NA		
				Heat Rise (°C)	15	15	16	17	19	20	22	24	28	NA	NA		
				CFM	774	700	623	546	439	339	---	---	---	---	---		
				BHP	0.12	0.13	0.13	0.14	0.14	0.15	---	---	---	---	---		
				Heat Rise (°F)	NA	NA	NA	NA	NA	NA	NA	NA	NA	NA	NA		
				Heat Rise (°C)	NA	NA	NA	NA	NA	NA	NA	NA	NA	NA	NA		
30060	25 - 55 (14 - 31)	Med-Low	Pink	CFM	906	843	771	707	624	548	451	340	---	---			
				BHP	0.18	0.18	0.19	0.20	0.20	0.21	0.21	0.22	---	---			
				Heat Rise (°F)	50	NA	NA	NA	NA	NA	NA	NA	NA	NA	NA		
				Heat Rise (°C)	28	NA	NA	NA	NA	NA	NA	NA	NA	NA	NA		
				CFM	1008	942	872	804	734	647	546	510	399	---			
				BHP	0.22	0.23	0.24	0.24	0.24	0.26	0.26	0.27	0.27	0.27	0.27		
		Medium	Red	Heat Rise (°F)	45	48	52	NA	NA	NA	NA	NA	NA	NA	NA		
				Heat Rise (°C)	25	27	29	NA	NA	NA	NA	NA	NA	NA	NA		
				CFM	1047	997	931	875	804	737	676	584	494	401			
				BHP	0.25	0.26	0.26	0.27	0.28	0.28	0.29	0.30	0.30	0.31			
				Heat Rise (°F)	43	45	48	51	NA	NA	NA	NA	NA	NA			
				Heat Rise (°C)	24	25	27	29	NA	NA	NA	NA	NA	NA			
Med-High ²	Orange	CFM	1125	1075	1019	956	891	825	760	695	594	491					
		BHP	0.30	0.31	0.32	0.32	0.33	0.34	0.34	0.35	0.35	0.34					
		Heat Rise (°F)	40	42	44	47	51	55	NA	NA	NA	NA					
		Heat Rise (°C)	22	23	25	26	28	30	NA	NA	NA	NA					
		CFM	1125	1075	1019	956	891	825	760	695	594	491					
		BHP	0.30	0.31	0.32	0.32	0.33	0.34	0.34	0.35	0.35	0.34					
High ¹	Black	Heat Rise (°F)	40	42	44	47	51	55	NA	NA	NA	NA					
		Heat Rise (°C)	22	23	25	26	28	30	NA	NA	NA	NA					

Dry Coil Air Delivery* – Horizontal and Downflow Discharge Unit 24–60 208/230VAC – 1 Phase (Cont.)

Unit Size	Heating Rise Range °F (°C)	Motor Speed	Wire Color	External Static Pressure (IN. W.C.)										
				0.1	0.2	0.3	0.4	0.5	0.6	0.7	0.8	0.9	1	
36060	25 - 55 (14 - 31)	Low ¹	Blue	CFM	1245	1188	1146	1094	1046	985	935	888	828	781
				BHP	0.34	0.34	0.35	0.36	0.37	0.37	0.38	0.39	0.39	0.40
				Heat Rise (°F)	36	38	39	41	43	46	48	51	54	NA
				Heat Rise (°C)	20	21	22	23	24	25	27	28	30	NA
		Med-Low ²	Pink	CFM	1302	1253	1213	1160	1113	1060	1008	963	908	863
				BHP	0.38	0.39	0.40	0.41	0.42	0.42	0.43	0.44	0.44	
				Heat Rise (°F)	35	36	37	39	40	42	45	47	50	52
				Heat Rise (°C)	19	20	21	22	22	24	25	26	28	29
		Medium ³	Red	CFM	1362	1322	1284	1230	1184	1141	1087	1044	996	954
				BHP	0.42	0.44	0.44	0.46	0.47	0.47	0.48	0.49	0.50	0.51
				Heat Rise (°F)	33	34	35	37	38	39	41	43	45	47
				Heat Rise (°C)	18	19	19	20	21	22	23	24	25	26
Med-High	Orange	CFM	1490	1448	1407	1364	1323	1279	1236	1192	1146	1099		
		BHP	0.54	0.55	0.57	0.57	0.58	0.59	0.60	0.61	0.62	0.62		
		Heat Rise (°F)	30	31	32	33	34	35	36	38	39	41		
		Heat Rise (°C)	17	17	18	18	19	20	20	21	22	23		
High	Black	CFM	1577	1538	1502	1457	1420	1373	1327	1282	1213	1148		
		BHP	0.65	0.65	0.67	0.67	0.68	0.69	0.69	0.69	0.68	0.67		
		Heat Rise (°F)	29	29	30	31	32	33	34	35	37	39		
		Heat Rise (°C)	16	16	17	17	18	18	19	20	21	22		
36090	35 - 65 (19 - 36)	Low ³	Blue	CFM	1245	1188	1146	1094	1046	985	935	888	828	781
				BHP	0.34	0.34	0.35	0.36	0.37	0.37	0.38	0.39	0.39	0.40
				Heat Rise (°F)	54	57	59	61	64	NA	NA	NA	NA	NA
				Heat Rise (°C)	30	31	33	34	36	NA	NA	NA	NA	NA
		Med-Low ²	Pink	CFM	1302	1253	1213	1160	1113	1060	1008	963	908	863
				BHP	0.38	0.39	0.40	0.41	0.42	0.42	0.43	0.44	0.44	0.45
				Heat Rise (°F)	52	54	55	58	60	63	NA	NA	NA	NA
				Heat Rise (°C)	29	30	31	32	34	35	NA	NA	NA	NA
		Medium	Red	CFM	1362	1322	1284	1230	1184	1141	1087	1044	996	954
				BHP	0.42	0.44	0.44	0.46	0.47	0.47	0.48	0.49	0.50	0.51
				Heat Rise (°F)	49	51	52	55	57	59	62	64	NA	NA
				Heat Rise (°C)	27	28	29	30	32	33	34	36	NA	NA
Med-High ₁	Orange	CFM	1490	1448	1407	1364	1323	1279	1236	1192	1146	1099		
		BHP	0.54	0.55	0.57	0.57	0.58	0.59	0.60	0.61	0.62	0.62		
		Heat Rise (°F)	45	46	48	49	51	52	54	56	59	61		
		Heat Rise (°C)	25	26	27	27	28	29	30	31	33	34		
High	Black	CFM	1577	1538	1502	1457	1420	1373	1327	1282	1213	1148		
		BHP	0.65	0.65	0.67	0.67	0.68	0.69	0.69	0.69	0.68	0.67		
		Heat Rise (°F)	43	44	45	46	47	49	51	52	55	58		
		Heat Rise (°C)	24	24	25	26	26	27	28	29	31	32		

Dry Coil Air Delivery* – Horizontal and Downflow Discharge Unit 24–60 208/230VAC – 1 Phase (Cont.)

Unit Size	Heating Rise Range °F (°C)	Motor Speed	Wire Color	External Static Pressure (IN. W.C.)										
				0.1	0.2	0.3	0.4	0.5	0.6	0.7	0.8	0.9	1	
42060	25 - 55 (14 - 31)	Low ³	Blue	CFM	1113	1069	1018	964	914	868	820	778	739	686
				BHP	0.16	0.17	0.18	0.19	0.20	0.21	0.23	0.24	0.25	0.26
				Heat Rise (°F)	40	42	44	47	49	52	55	NA	NA	NA
		Med-Low ¹	Pink	CFM	1205	1167	1120	1064	1016	975	930	886	848	811
				BHP	0.19	0.21	0.22	0.23	0.24	0.25	0.27	0.27	0.29	0.30
				Heat Rise (°F)	37	39	40	42	44	46	48	51	53	55
		Medium ²	Red	CFM	1442	1407	1372	1326	1284	1245	1205	1160	1121	1085
				BHP	0.31	0.33	0.34	0.35	0.36	0.38	0.39	0.40	0.41	0.42
				Heat Rise (°F)	31	32	33	34	35	36	37	39	40	41
		Med-High	Orange	CFM	1510	1458	1433	1390	1358	1311	1267	1227	1189	1151
				BHP	0.34	0.36	0.37	0.39	0.40	0.42	0.43	0.44	0.45	0.46
				Heat Rise (°F)	30	31	31	32	33	34	36	37	38	39
High	Black	CFM	1581	1545	1509	1475	1443	1401	1357	1318	1279	1247		
		BHP	0.39	0.41	0.43	0.44	0.46	0.47	0.49	0.49	0.51	0.52		
		Heat Rise (°F)	28	29	30	31	31	32	33	34	35	36		
42090	35 - 65 (19 - 36)	Low ³	Blue	CFM	1113	1069	1018	964	914	868	820	778	739	686
				BHP	0.16	0.17	0.18	0.19	0.20	0.21	0.23	0.24	0.25	0.26
				Heat Rise (°F)	61	63	NA	NA	NA	NA	NA	NA	NA	NA
		Med-Low	Pink	CFM	1205	1167	1120	1064	1016	975	930	886	848	811
				BHP	0.19	0.21	0.22	0.23	0.24	0.25	0.27	0.27	0.29	0.30
				Heat Rise (°F)	56	58	61	64	NA	NA	NA	NA	NA	NA
		Medium ²	Red	CFM	1442	1407	1372	1326	1284	1245	1205	1160	1121	1085
				BHP	0.31	0.33	0.34	0.35	0.36	0.38	0.39	0.40	0.41	0.42
				Heat Rise (°F)	47	48	49	51	53	55	56	59	61	63
		Med-High ₁	Orange	CFM	1510	1458	1433	1390	1358	1311	1267	1227	1189	1151
				BHP	0.34	0.36	0.37	0.39	0.40	0.42	0.43	0.44	0.45	0.46
				Heat Rise (°F)	45	47	47	49	50	52	54	55	57	59
High	Black	CFM	1581	1545	1509	1475	1443	1401	1357	1318	1279	1247		
		BHP	0.39	0.41	0.43	0.44	0.46	0.47	0.49	0.49	0.51	0.52		
		Heat Rise (°F)	43	44	45	46	47	48	50	52	53	54		

Dry Coil Air Delivery* – Horizontal and Downflow Discharge Unit 24–60 208/230VAC – 1 Phase (Cont.)

Unit Size	Heating Rise Range °F (°C)	Motor Speed	Wire Color	External Static Pressure (IN. W.C.)										
				0.1	0.2	0.3	0.4	0.5	0.6	0.7	0.8	0.9	1	
48090	35 - 65 (19 - 36)	Low ¹	Blue	CFM	1378	1344	1295	1260	1216	1179	1135	1087	1035	995
				BHP	0.26	0.27	0.29	0.31	0.31	0.33	0.34	0.36	0.36	0.38
				Heat Rise (°F)	49	51	52	54	56	58	60	62	NA	NA
				Heat Rise (°C)	27	28	29	30	31	32	33	35	NA	NA
		Med-Low ²	Pink	CFM	1696	1671	1631	1607	1574	1539	1507	1463	1432	1393
				BHP	0.45	0.47	0.49	0.50	0.52	0.52	0.54	0.55	0.57	0.58
				Heat Rise (°F)	40	41	42	42	43	44	45	46	47	49
				Heat Rise (°C)	22	23	23	23	24	25	25	26	26	27
		Medium ³	Red	CFM	1994	1968	1943	1910	1882	1835	1774	1702	1614	1512
				BHP	0.72	0.73	0.75	0.76	0.78	0.78	0.76	0.73	0.70	0.66
				Heat Rise (°F)	NA	NA	35	36	36	37	38	40	42	45
				Heat Rise (°C)	NA	NA	19	20	20	21	21	22	23	25
		Med-High	Orange	CFM	2054	2013	1986	1964	1919	1854	1779	1695	1605	1498
				BHP	0.77	0.79	0.80	0.82	0.81	0.80	0.76	0.74	0.69	0.65
Heat Rise (°F)	NA			NA	NA	35	35	37	38	40	42	45		
Heat Rise (°C)	NA			NA	NA	19	20	20	21	22	23	25		
High	Black	CFM	2267	2201	2133	2071	1997	1923	1835	1739	1654	1551		
		BHP	1.03	1.00	0.97	0.93	0.89	0.86	0.82	0.78	0.74	0.69		
		Heat Rise (°F)	NA	NA	NA	NA	NA	35	37	39	41	44		
		Heat Rise (°C)	NA	NA	NA	NA	NA	20	21	22	23	24		
48115	30 - 60 (17 - 33)	Low ³	Blue	CFM	1378	1344	1295	1260	1216	1179	1135	1087	1035	995
				BHP	0.26	0.27	0.29	0.31	0.31	0.33	0.34	0.36	0.36	0.38
				Heat Rise (°F)	NA	NA	NA	NA	NA	NA	NA	NA	NA	NA
				Heat Rise (°C)	NA	NA	NA	NA	NA	NA	NA	NA	NA	NA
		Med-Low ²	Pink	CFM	1696	1671	1631	1607	1574	1539	1507	1463	1432	1393
				BHP	0.45	0.47	0.49	0.50	0.52	0.52	0.54	0.55	0.57	0.58
				Heat Rise (°F)	51	52	53	54	55	56	58	59	NA	NA
				Heat Rise (°C)	28	29	30	30	31	31	32	33	NA	NA
		Medium ¹	Red	CFM	1994	1968	1943	1910	1882	1835	1774	1702	1614	1512
				BHP	0.72	0.73	0.75	0.76	0.78	0.78	0.76	0.73	0.70	0.66
				Heat Rise (°F)	43	44	45	45	46	47	49	51	54	57
				Heat Rise (°C)	24	24	25	25	26	26	27	28	30	32
		Med-High	Orange	CFM	2054	2013	1986	1964	1919	1854	1779	1695	1605	1498
				BHP	0.77	0.79	0.80	0.82	0.81	0.80	0.76	0.74	0.69	0.65
Heat Rise (°F)	42			43	44	44	45	47	49	51	54	58		
Heat Rise (°C)	23			24	24	25	25	26	27	28	30	32		
High	Black	CFM	2267	2201	2133	2071	1997	1923	1835	1739	1654	1551		
		BHP	1.03	1.00	0.97	0.93	0.89	0.86	0.82	0.78	0.74	0.69		
		Heat Rise (°F)	38	39	41	42	43	45	47	50	52	56		
		Heat Rise (°C)	21	22	23	23	24	25	26	28	29	31		

Dry Coil Air Delivery* – Horizontal and Downflow Discharge Unit 24–60 208/230VAC – 1 Phase (Cont.)

Unit Size	Heating Rise Range °F (°C)	Motor Speed	Wire Color	External Static Pressure (IN. W.C.)											
				0.1	0.2	0.3	0.4	0.5	0.6	0.7	0.8	0.9	1		
48130	35 - 65 (19 - 36)	Low ³	Blue	CFM	1378	1344	1295	1260	1216	1179	1135	1087	1035	995	
				BHP	0.26	0.27	0.29	0.31	0.31	0.33	0.34	0.36	0.36	0.38	
				Heat Rise (°F)	NA	NA	NA	NA	NA	NA	NA	NA	NA	NA	NA
				Heat Rise (°C)	NA	NA	NA	NA	NA	NA	NA	NA	NA	NA	NA
		Med-Low ²	Pink	CFM	1696	1671	1631	1607	1574	1539	1507	1463	1432	1393	
				BHP	0.45	0.47	0.49	0.50	0.52	0.52	0.54	0.55	0.57	0.58	
				Heat Rise (°F)	57	58	59	60	61	62	64	NA	NA	NA	
				Heat Rise (°C)	31	32	33	33	34	35	35	NA	NA	NA	
		Medium	Red	CFM	1994	1968	1943	1910	1882	1835	1774	1702	1614	1512	
				BHP	0.72	0.73	0.75	0.76	0.78	0.78	0.76	0.73	0.70	0.66	
				Heat Rise (°F)	48	49	49	50	51	52	54	56	60	64	
				Heat Rise (°C)	27	27	27	28	28	29	30	31	33	35	
Med-High ¹	Orange	CFM	2054	2013	1986	1964	1919	1854	1779	1695	1605	1498			
		BHP	0.77	0.79	0.80	0.82	0.81	0.80	0.76	0.74	0.69	0.65			
		Heat Rise (°F)	47	48	48	49	50	52	54	57	60	64			
		Heat Rise (°C)	26	27	27	27	28	29	30	32	33	36			
High	Black	CFM	2267	2201	2133	2071	1997	1923	1835	1739	1654	1551			
		BHP	1.03	1.00	0.97	0.93	0.89	0.86	0.82	0.78	0.74	0.69			
		Heat Rise (°F)	42	44	45	46	48	50	52	55	58	62			
		Heat Rise (°C)	24	24	25	26	27	28	29	31	32	34			
60090	35 - 65 (19 - 36)	Low ³	Blue	CFM	1330	1277	1232	1191	1147	1103	1060	1004	963	919	
				BHP	0.26	0.27	0.29	0.30	0.31	0.32	0.33	0.34	0.36	0.37	
				Heat Rise (°F)	51	53	55	57	59	62	64	68	NA	NA	
				Heat Rise (°C)	28	30	31	32	33	34	36	38	NA	NA	
		Med-Low ¹	Pink	CFM	1475	1436	1399	1351	1317	1270	1236	1188	1152	1105	
				BHP	0.35	0.36	0.37	0.38	0.40	0.41	0.42	0.43	0.45	0.45	
				Heat Rise (°F)	46	47	49	50	52	53	55	57	59	61	
				Heat Rise (°C)	26	26	27	28	29	30	31	32	33	34	
		Medium ²	Red	CFM	1736	1710	1668	1630	1600	1557	1522	1479	1450	1406	
				BHP	0.53	0.54	0.55	0.58	0.59	0.60	0.62	0.63	0.64	0.65	
				Heat Rise (°F)	NA	NA	41	42	42	44	45	46	47	48	
				Heat Rise (°C)	NA	NA	23	23	24	24	25	25	26	27	
Med-High	Orange	CFM	1935	1909	1867	1836	1808	1766	1696	1619	1535	1454			
		BHP	0.71	0.73	0.74	0.76	0.78	0.79	0.77	0.75	0.72	0.68			
		Heat Rise (°F)	NA	NA	NA	37	38	38	40	42	44	47			
		Heat Rise (°C)	NA	NA	NA	21	21	21	22	23	25	26			
High	Black	CFM	2205	2150	2078	2011	1941	1852	1779	1672	1572	1473			
		BHP	1.04	1.02	0.99	0.95	0.92	0.87	0.85	0.79	0.75	0.70			
		Heat Rise (°F)	NA	NA	NA	NA	NA	37	38	41	43	46			
		Heat Rise (°C)	NA	NA	NA	NA	NA	20	21	23	24	26			

Dry Coil Air Delivery* – Horizontal and Downflow Discharge Unit 24–60 208/230VAC – 1 Phase (Cont.)

Unit Size	Heating Rise Range °F (°C)	Motor Speed	Wire Color	External Static Pressure (IN. W.C.)											
				0.1	0.2	0.3	0.4	0.5	0.6	0.7	0.8	0.9	1		
60115	30 - 60 (17 - 33)	Low ³	Blue	CFM	1330	1277	1232	1191	1147	1103	1060	1004	963	919	
				BHP	0.26	0.27	0.29	0.30	0.31	0.32	0.33	0.34	0.36	0.37	
				Heat Rise (°F)	NA	NA	NA	NA	NA	NA	NA	NA	NA	NA	NA
				Heat Rise (°C)	NA	NA	NA	NA	NA	NA	NA	NA	NA	NA	NA
				CFM	1475	1436	1399	1351	1317	1270	1236	1188	1152	1105	
				BHP	0.35	0.36	0.37	0.38	0.40	0.41	0.42	0.43	0.45	0.45	
	Med-Low	Pink	Med-Low	Pink	Heat Rise (°F)	59	60	NA	NA	NA	NA	NA	NA	NA	NA
					Heat Rise (°C)	33	34	NA	NA	NA	NA	NA	NA	NA	
					CFM	1736	1710	1668	1630	1600	1557	1522	1479	1450	1406
					BHP	0.53	0.54	0.55	0.58	0.59	0.60	0.62	0.63	0.64	0.65
					Heat Rise (°F)	50	51	52	53	54	56	57	59	60	60
					Heat Rise (°C)	28	28	29	30	30	31	32	33	33	33
60130	35 - 65 (19 - 36)	Med-High ₁	Orange	CFM	1935	1909	1867	1836	1808	1766	1696	1619	1535	1454	
				BHP	0.71	0.73	0.74	0.76	0.78	0.79	0.77	0.75	0.72	0.68	
				Heat Rise (°F)	45	45	46	47	48	49	51	54	56	60	
				Heat Rise (°C)	25	25	26	26	27	27	28	30	31	33	
				CFM	2205	2150	2078	2011	1941	1852	1779	1672	1572	1473	
				BHP	1.04	1.02	0.99	0.95	0.92	0.87	0.85	0.79	0.75	0.70	
	High	Black	High	Black	Heat Rise (°F)	39	40	42	43	45	47	49	52	55	59
					Heat Rise (°C)	22	22	23	24	25	26	27	29	31	33
					CFM	1330	1277	1232	1191	1147	1103	1060	1004	963	919
					BHP	0.26	0.27	0.29	0.30	0.31	0.32	0.33	0.34	0.36	0.37
					Heat Rise (°F)	NA	NA	NA	NA	NA	NA	NA	NA	NA	NA
					Heat Rise (°C)	NA	NA	NA	NA	NA	NA	NA	NA	NA	NA
60130	35 - 65 (19 - 36)	Med-Low	Pink	CFM	1475	1436	1399	1351	1317	1270	1236	1188	1152	1105	
				BHP	0.35	0.36	0.37	0.38	0.40	0.41	0.42	0.43	0.45	0.45	
				Heat Rise (°F)	65	NA	NA	NA	NA	NA	NA	NA	NA	NA	
				Heat Rise (°C)	36	NA	NA	NA	NA	NA	NA	NA	NA	NA	
				CFM	1736	1710	1668	1630	1600	1557	1522	1479	1450	1406	
				BHP	0.53	0.54	0.55	0.58	0.59	0.60	0.62	0.63	0.64	0.65	
	Med-High ₁	Orange	Med-High ₁	Orange	Heat Rise (°F)	55	56	58	59	60	62	63	65	NA	NA
					Heat Rise (°C)	31	31	32	33	33	34	35	36	NA	NA
					CFM	1935	1909	1867	1836	1808	1766	1696	1619	1535	1454
					BHP	0.71	0.73	0.74	0.76	0.78	0.79	0.77	0.75	0.72	0.68
					Heat Rise (°F)	50	50	51	52	53	54	57	59	63	NA
					Heat Rise (°C)	28	28	29	29	30	30	31	33	35	NA
High	Black	High	Black	CFM	2205	2150	2078	2011	1941	1852	1779	1672	1572	1473	
				BHP	1.04	1.02	0.99	0.95	0.92	0.87	0.85	0.79	0.75	0.70	
				Heat Rise (°F)	44	45	46	48	50	52	54	57	61	65	
				Heat Rise (°C)	24	25	26	27	28	29	30	32	34	36	

*Air delivery values are without air filter and are for dry coil (See Wet Coil Pressure Drop table).

¹ Factory-shipped heating speed

² Factory-shipped cooling speed

³ Factory-shipped continuous fan speed

"NA" = Not allowed for heating speed

NOTE: Deduct field-supplied air filter pressure drop and wet coil pressure drop to obtain external static pressure available for ducting.

Shaded areas indicate speed/static combinations that are not permitted for dehumidification speed.

Dry Coil Air Delivery* – Horizontal Discharge – Unit 30–60 3 Phase Models Only

Unit	Heating Rise Range °F (°C)	Motor Speed	Wire Color	External Static Pressure (IN. W.C.)												
				0.1	0.2	0.3	0.4	0.5	0.6	0.7	0.8	0.9				
30040	30 – 60 (17 – 33)	Low	Blue	CFM	741	638	547	415	--	--	--	--	--	--	--	
				Heating Rise (°F)	41	47	55	NA	NA	NA	NA	NA	NA	NA	NA	NA
				Heating Rise (°C)	23	26	31	NA	NA	NA	NA	NA	NA	NA	NA	NA
				CFM	973	887	823	733	665	538	451	--	--	--	--	--
				Heating Rise (°F)	31	34	37	41	45	56	NA	NA	NA	NA	NA	NA
		Heating Rise (°C)	17	19	20	23	25	31	NA	NA	NA	NA	NA	NA		
		Medium	Red	CFM	1088	1023	954	881	800	723	658	563	461	NA	NA	
				Heating Rise (°F)	NA	30	32	34	38	42	46	54	NA	NA	NA	
				Heating Rise (°C)	NA	16	18	19	21	23	26	30	NA	NA	NA	
				CFM	1140	1064	996	915	840	758	687	564	480	NA	NA	
Heating Rise (°F)	NA			NA	30	33	36	40	44	54	NA	NA	NA			
30060	25 – 55 (14 – 31)	Med–High ²	Orange	CFM	NA	NA	17	18	20	22	24	30	NA	NA		
				Heating Rise (°F)	NA	NA	17	18	20	22	24	30	NA	NA		
				Heating Rise (°C)	NA	NA	10	10	11	12	14	17	NA	NA		
				CFM	1202	1140	1082	1015	961	881	810	732	631	NA	NA	
				Heating Rise (°F)	NA	NA	NA	30	31	34	37	41	48	NA	NA	
		High	Black	Heating Rise (°C)	NA	NA	NA	17	19	21	23	27	NA	NA		
				CFM	741	638	547	415	--	--	--	--	--	--		
				Heating Rise (°F)	NA	NA	NA	NA	NA	NA	NA	NA	NA	NA		
				Heating Rise (°C)	NA	NA	NA	NA	NA	NA	NA	NA	NA	NA		
				CFM	973	887	823	733	665	538	451	--	--	--		
Med–Low	Pink	Heating Rise (°F)	46	50	54	NA	NA	NA	NA	NA	NA	NA				
		Heating Rise (°C)	25	28	30	NA	NA	NA	NA	NA	NA	NA				
		CFM	1088	1023	954	881	800	723	658	563	461	NA				
		Heating Rise (°F)	41	43	47	50	NA	NA	NA	NA	NA	NA				
		Heating Rise (°C)	23	24	26	28	NA	NA	NA	NA	NA	NA				
Med–High ²	Orange	CFM	1140	1064	996	915	840	758	687	564	480	NA				
		Heating Rise (°F)	39	42	45	49	53	NA	NA	NA	NA	NA				
		Heating Rise (°C)	22	23	25	27	29	NA	NA	NA	NA	NA				
		CFM	1202	1140	1082	1015	961	881	810	732	631	NA				
		Heating Rise (°F)	37	39	41	44	46	50	55	NA	NA	NA				
36060	25 – 55 (14 – 31)	High ¹	Black	Heating Rise (°C)	21	22	23	24	26	28	30	NA	NA			
				CFM	1234	1168	1093	1021	961	894	825	759	687	NA		
				Heating Rise (°F)	36	38	41	44	46	50	54	NA	NA	NA		
				Heating Rise (°C)	20	21	23	24	26	28	30	NA	NA	NA		
				CFM	1290	1223	1154	1090	1027	977	894	828	762	NA		
		Med–Low	Pink	Heating Rise (°F)	34	36	39	41	43	45	50	54	NA	NA		
				Heating Rise (°C)	19	20	21	23	24	25	28	30	NA	NA		
				CFM	1354	1290	1226	1158	1102	1046	981	918	843	NA		
				Heating Rise (°F)	33	34	36	38	40	42	45	48	53	NA		
				Heating Rise (°C)	18	19	20	21	22	24	25	27	29	NA		
Med–High	Orange	CFM	1606	1546	1489	1430	1371	1316	1258	1208	1140	NA				
		Heating Rise (°F)	28	29	30	31	32	34	35	37	39	NA				
		Heating Rise (°C)	15	16	17	17	18	19	20	20	22	NA				
		CFM	1630	1580	1517	1463	1407	1339	1277	1210	1131	NA				
		Heating Rise (°F)	27	28	29	30	32	33	35	37	39	NA				
Heating Rise (°C)	15	16	16	17	18	18	19	20	22	NA						

See Legend and Notes on Page 26.

Dry Coil Air Delivery* – Horizontal Discharge – Unit 30–60 3 Phase Models Only (Cont.)

Unit	Heating Rise Range °F (°C)	Motor Speed	Wire Color		External Static Pressure (IN. W.C.)											
					0.1	0.2	0.3	0.4	0.5	0.6	0.7	0.8	0.9			
36090	35 – 65 (19 – 36)	Low	Blue	CFM	1234	1168	1093	1021	961	894	825	759	687			
				Heating Rise (°F)	55	58	62	NA	NA	NA	NA	NA	NA	NA	NA	
				Heating Rise (°C)	31	32	35	NA	NA	NA	NA	NA	NA	NA	NA	
		Med–Low	Pink	CFM	1290	1223	1154	1090	1027	977	927	894	828	762		
				Heating Rise (°F)	53	56	59	62	NA	NA	NA	NA	NA	NA	NA	
				Heating Rise (°C)	29	31	33	35	NA	NA	NA	NA	NA	NA	NA	
		Medium ²	Red	CFM	1354	1290	1226	1158	1102	1046	981	918	843			
				Heating Rise (°F)	50	53	55	59	62	65	NA	NA	NA	NA		
				Heating Rise (°C)	28	29	31	33	34	36	NA	NA	NA	NA		
		Med–High	Orange	CFM	1606	1546	1489	1430	1371	1316	1258	1208	1140			
				Heating Rise (°F)	42	44	46	48	50	52	54	56	60			
				Heating Rise (°C)	24	24	25	26	28	29	30	31	33			
High ¹	Black	CFM	1630	1580	1517	1463	1407	1339	1277	1210	1131					
		Heating Rise (°F)	42	43	45	46	48	51	53	56	60					
		Heating Rise (°C)	23	24	25	26	27	28	30	31	33					
Low ¹	Blue	CFM	1295	1234	1182	1126	1075	1016	955	898	857					
		Heating Rise (°F)	34	36	38	39	41	44	47	49	52					
		Heating Rise (°C)	19	20	21	22	23	24	26	27	29					
Med–Low	Pink	CFM	1345	1282	1235	1194	1140	1095	1027	974	921					
		Heating Rise (°F)	33	35	36	37	39	41	43	46	48					
		Heating Rise (°C)	18	19	20	21	22	23	24	25	27					
Medium	Red	CFM	1505	1452	1413	1358	1323	1282	1234	1169	1130					
		Heating Rise (°F)	30	31	31	33	34	35	36	38	39					
		Heating Rise (°C)	16	17	17	18	19	19	20	21	22					
Med–High ²	Orange	CFM	1545	1492	1449	1411	1362	1313	1278	1231	1188					
		Heating Rise (°F)	29	30	31	31	33	34	35	36	37					
		Heating Rise (°C)	16	17	17	17	18	19	19	20	21					
High	Black	CFM	1705	1643	1607	1568	1518	1483	1448	1404	1360					
		Heating Rise (°F)	26	27	28	28	29	30	31	32	33					
		Heating Rise (°C)	14	15	15	16	16	17	17	18	18					
Low	Blue	CFM	1295	1234	1182	1126	1075	1016	955	898	857					
		Heating Rise (°F)	53	55	58	60	63	NA	NA	NA	NA	NA				
		Heating Rise (°C)	29	31	32	34	35	NA	NA	NA	NA	NA				
Med–Low	Pink	CFM	1345	1282	1235	1194	1140	1095	1027	974	921					
		Heating Rise (°F)	51	53	55	57	60	62	NA	NA	NA	NA				
		Heating Rise (°C)	28	29	31	32	33	35	NA	NA	NA	NA				
Medium ¹	Red	CFM	1505	1452	1413	1358	1323	1282	1234	1169	1130					
		Heating Rise (°F)	45	47	48	50	51	53	55	58	60					
		Heating Rise (°C)	25	26	27	28	29	29	31	32	33					
Med–High ²	Orange	CFM	1545	1492	1449	1411	1362	1313	1278	1231	1188					
		Heating Rise (°F)	44	46	47	48	50	52	53	55	57					
		Heating Rise (°C)	24	25	26	27	28	29	30	31	32					
High	Black	CFM	1705	1643	1607	1568	1518	1483	1448	1404	1360					
		Heating Rise (°F)	40	41	42	43	45	46	47	48	50					
		Heating Rise (°C)	22	23	24	24	25	25	26	26	27					

See Legend and Notes on Page 26.

Dry Coil Air Delivery* – Horizontal Discharge – Unit 30–60 3 Phase Models Only (Cont.)

Unit	Heating Rise Range °F (°C)	Motor Speed	Wire Color	External Static Pressure (IN. W.C.)											
				0.1	0.2	0.3	0.4	0.5	0.6	0.7	0.8	0.9			
48090	35 – 65 (19 – 36)	Low ¹	Blue	CFM	1402	1351	1311	1263	1224	1172	1136	1080	1041		
				Heating Rise (°F)	49	50	52	54	56	58	60	63	65		
		Med–Low	Pink	CFM	27	28	29	30	31	32	33	35	36		
				Heating Rise (°F)	1457	1404	1367	1318	1284	1233	1197	1144	1104		
		Medium ²	Red	CFM	47	48	50	52	53	55	57	59	62		
				Heating Rise (°F)	26	27	28	29	29	31	32	33	34		
		Med–High	Orange	CFM	1736	1695	1642	1601	1553	1512	1465	1427	1381		
				Heating Rise (°F)	39	40	41	42	44	45	46	48	49		
		High	Black	CFM	22	22	23	24	24	25	26	26	27		
				Heating Rise (°F)	2149	2111	2062	2026	1980	1945	1905	1864	1793		
Low	Blue	CFM	NA	NA	NA	NA	NA	35	36	36	38				
		Heating Rise (°F)	NA	NA	NA	NA	NA	19	20	20	21				
Med–Low	Pink	CFM	2344	2306	2259	2203	2141	2070	1991	1902	1803				
		Heating Rise (°F)	NA	NA	NA	NA	NA	NA	NA	NA	36	38			
Medium ²	Red	CFM	1402	1351	1311	1263	1224	1172	1136	1080	1041				
		Heating Rise (°F)	NA	NA	NA	NA	NA	NA	NA	NA	NA	NA			
Med–High ¹	Orange	CFM	1457	1404	1367	1318	1284	1233	1197	1144	1104				
		Heating Rise (°F)	60	NA	NA	NA	NA	NA	NA	NA	NA	NA			
High	Black	CFM	33	NA	NA	NA	NA	NA	NA	NA	NA				
		Heating Rise (°F)	1736	1695	1642	1601	1553	1512	1465	1427	1381				
Medium ²	Red	CFM	50	51	53	54	56	57	59	NA	NA				
		Heating Rise (°F)	28	28	29	30	31	32	33	NA	NA				
High	Black	CFM	2149	2111	2062	2026	1980	1945	1905	1864	1793				
		Heating Rise (°F)	40	41	42	43	44	45	46	47	48				
Low	Blue	CFM	22	23	23	24	24	25	25	26	27				
		Heating Rise (°F)	2344	2306	2259	2203	2141	2070	1991	1902	1803				
Med–Low	Pink	CFM	37	38	38	39	41	42	44	46	48				
		Heating Rise (°F)	21	21	21	22	23	23	24	25	27				
Medium ²	Red	CFM	1402	1351	1311	1263	1224	1172	1136	1080	1041				
		Heating Rise (°F)	NA	NA	NA	NA	NA	NA	NA	NA	NA	NA			
Med–High ¹	Orange	CFM	NA	NA	NA	NA	NA	NA	NA	NA	NA				
		Heating Rise (°F)	1457	1404	1367	1318	1284	1233	1197	1144	1104				
High	Black	CFM	NA	NA	NA	NA	NA	NA	NA	NA	NA				
		Heating Rise (°F)	NA	NA	NA	NA	NA	NA	NA	NA	NA	NA			
Medium ²	Red	CFM	1736	1695	1642	1601	1553	1512	1465	1427	1381				
		Heating Rise (°F)	55	57	59	60	62	64	NA	NA	NA				
Med–High ¹	Orange	CFM	31	32	33	33	34	35	NA	NA	NA				
		Heating Rise (°F)	2149	2111	2062	2026	1980	1945	1905	1864	1793				
High	Black	CFM	45	46	47	48	49	50	51	52	54				
		Heating Rise (°F)	25	25	26	26	27	28	28	29	30				
Medium ²	Red	CFM	2344	2306	2259	2203	2141	2070	1991	1902	1803				
		Heating Rise (°F)	41	42	43	44	45	47	48	51	53				
High	Black	CFM	23	23	24	24	25	26	27	28	30				
		Heating Rise (°F)	NA	NA	NA	NA	NA	NA	NA	NA	NA	NA			

See Legend and Notes on Page 26.

Dry Coil Air Delivery* – Horizontal Discharge – Unit 30–60 3 Phase Models Only (Cont.)

Unit	Heating Rise Range °F (°C)	Motor Speed	Wire Color		External Static Pressure (IN. W.C.)										
					0.1	0.2	0.3	0.4	0.5	0.6	0.7	0.8	0.9		
60090		Low ¹	Blue	CFM	1445	1389	1341	1281	1236	1189	1139	1072	1027		
				Heating Rise (°F)	47	49	51	53	55	57	60	63	NA		
				Heating Rise (°C)	26	27	28	29	31	32	33	35	NA		
		Med–Low	Pink	CFM	1678	1635	1602	1558	1513	1474	1438	1404	1349		
				Heating Rise (°F)	41	42	42	44	45	46	47	48	50		
				Heating Rise (°C)	23	23	24	24	25	26	26	27	28		
	35 – 65 (19 – 36)	Medium ²	Red	CFM	1962	1915	1880	1843	1794	1753	1711	1675	1628		
				Heating Rise (°F)	35	36	36	37	38	39	40	41	42		
				Heating Rise (°C)	19	20	20	20	21	22	22	23	23		
		Med–High	Orange	CFM	2131	2088	2065	2013	1982	1941	1888	1860	1785		
				Heating Rise (°F)	NA	NA	NA	NA	NA	35	36	37	38		
				Heating Rise (°C)	NA	NA	NA	NA	NA	19	20	20	21		
60115		High	Black	CFM	2461	2409	2339	2286	2192	2140	2062	1968	1874		
				Heating Rise (°F)	NA	NA	NA	NA	NA	NA	NA	35	36		
				Heating Rise (°C)	NA	NA	NA	NA	NA	NA	NA	19	20		
		Low	Blue	CFM	1445	1389	1341	1281	1236	1189	1139	1072	1027		
				Heating Rise (°F)	60	NA	NA	NA	NA	NA	NA	NA	NA		
				Heating Rise (°C)	33	NA	NA	NA	NA	NA	NA	NA	NA		
	30 – 60 (17 – 33)	Med–Low	Pink	CFM	1678	1635	1602	1558	1513	1474	1438	1404	1349		
				Heating Rise (°F)	52	53	54	56	57	59	60	NA	NA		
				Heating Rise (°C)	29	30	30	31	32	33	34	NA	NA		
		Medium ²	Red	CFM	1962	1915	1880	1843	1794	1753	1711	1675	1628		
				Heating Rise (°F)	44	45	46	47	48	50	51	52	53		
				Heating Rise (°C)	25	25	26	26	27	28	28	29	30		
35 – 65 (19 – 36)	Med–High ¹	Orange	CFM	2131	2088	2065	2013	1982	1941	1888	1860	1785			
			Heating Rise (°F)	41	42	42	43	44	45	46	47	49			
			Heating Rise (°C)	23	23	23	24	24	25	26	26	27			
	High	Black	CFM	2461	2409	2339	2286	2192	2140	2062	1968	1874			
			Heating Rise (°F)	35	36	37	38	40	41	42	44	46			
			Heating Rise (°C)	20	20	21	21	22	23	23	25	26			
60130		Low	Blue	CFM	1445	1389	1341	1281	1236	1189	1139	1072	1027		
				Heating Rise (°F)	NA	NA	NA	NA	NA	NA	NA	NA	NA		
				Heating Rise (°C)	NA	NA	NA	NA	NA	NA	NA	NA	NA		
		Med–Low	Pink	CFM	1678	1635	1602	1558	1513	1474	1438	1404	1349		
				Heating Rise (°F)	57	59	60	62	64	65	NA	NA	NA		
				Heating Rise (°C)	32	33	33	34	35	36	NA	NA	NA		
	35 – 65 (19 – 36)	Medium ²	Red	CFM	1962	1915	1880	1843	1794	1753	1711	1675	1628		
				Heating Rise (°F)	49	50	51	52	54	55	56	57	59		
				Heating Rise (°C)	27	28	28	29	30	31	31	32	33		
		Med–High ¹	Orange	CFM	2131	2088	2065	2013	1982	1941	1888	1860	1785		
				Heating Rise (°F)	45	46	47	48	49	50	51	52	54		
				Heating Rise (°C)	25	26	26	27	27	28	28	29	30		
High	Black	CFM	2461	2409	2339	2286	2192	2140	2062	1968	1874				
		Heating Rise (°F)	39	40	41	42	44	45	47	49	51				
		Heating Rise (°C)	22	22	23	23	24	25	26	27	29				

*Air delivery values are without air filter and are for dry coil (See Wet Coil Pressure Drop table).

¹ Factory-shipped heating speed

² Factory-shipped cooling speed

"NA" = Not allowed for heating speed

Note: Duct field-supplied air filter pressure drop and wet coil pressure drop to obtain external static pressure available for ducting.

Note: Duct field-supplied air filter pressure drop and wet coil pressure drop to obtain external static pressure available for ducting.

Note: Duct field-supplied air filter pressure drop and wet coil pressure drop to obtain external static pressure available for ducting.

Note: Duct field-supplied air filter pressure drop and wet coil pressure drop to obtain external static pressure available for ducting.

Dry Coil Air Delivery – Downflow Discharge 3 Phase Models Only (Cont.)

Unit	Heating Rise Range	Motor Speed	Wire Color	External Static Pressure (IN. W.C.)																					
				0.1	0.2	0.3	0.4	0.5	0.6	0.7	0.8	0.9	1.0												
30040	30 - 60°F (17 - 33°C)	Low	Blue	CFM	756	669	548	457	---	---	---	---	---	---	---	---	---	---	---	---					
				WATTS	84	90	96	106	---	---	---	---	---	---	---	---	---	---	---	---	---	---			
				BHP	0.09	0.10	0.10	0.11	---	---	---	---	---	---	---	---	---	---	---	---	---	---	---		
				Heating Rise (°F)	40	45	55	NA	NA	NA	NA	NA	NA	NA	NA	NA	NA	NA	NA	NA	NA	NA	NA	NA	
				Heating Rise (°C)	22	25	31	NA	NA	NA	NA	NA	NA	NA	NA	NA	NA	NA	NA	NA	NA	NA	NA	NA	NA
				CFM	1002	928	842	733	660	560	450	---	---	---	---	---	---	---	---	---	---	---	---	---	---
		Med-Low ¹	Pink	WATTS	144	155	161	173	185	192	203	---	---	---	---	---	---	---	---	---	---	---	---		
				BHP	0.15	0.17	0.17	0.19	0.20	0.21	0.22	---	---	---	---	---	---	---	---	---	---	---	---	---	
				Heating Rise (°F)	30	33	36	41	46	54	NA	NA	NA	NA	NA	NA	NA	NA	NA	NA	NA	NA	NA	NA	
				Heating Rise (°C)	17	18	20	23	25	30	NA	NA	NA	NA	NA	NA	NA	NA	NA	NA	NA	NA	NA	NA	
				CFM	1110	1025	967	879	814	706	611	509	461	---	---	---	---	---	---	---	---	---	---	---	---
				WATTS	188	195	205	211	223	236	243	255	243	---	---	---	---	---	---	---	---	---	---	---	---
				BHP	0.20	0.21	0.22	0.23	0.24	0.25	0.26	---	---	---	---	---	---	---	---	---	---	---	---	---	---
				Heating Rise (°C)	NA	NA	NA	34	37	43	49	59	NA	NA	NA	NA	NA	NA	NA	NA	NA	NA	NA	NA	NA
30060	25 - 55°F (14 - 31°C)	High	Black	CFM	1160	1091	1004	945	866	804	699	615	496	---	---	---	---	---	---	---	---				
				WATTS	213	225	232	243	249	261	273	285	291	---	---	---	---	---	---	---	---	---	---		
				BHP	0.23	0.24	0.25	0.26	0.27	0.28	0.29	0.31	0.31	---	---	---	---	---	---	---	---	---	---	---	
				Heating Rise (°F)	NA	NA	NA	17	19	21	24	27	33	NA	NA	NA	NA	NA	NA	NA	NA	NA	NA	NA	
				Heating Rise (°C)	NA	NA	NA	17	19	21	24	27	33	NA	NA	NA	NA	NA	NA	NA	NA	NA	NA	NA	
				CFM	1240	1173	1110	1031	966	902	821	726	626	---	---	---	---	---	---	---	---	---	---	---	---
		Med-High ²	Orange	WATTS	254	266	274	284	295	302	315	327	331	---	---	---	---	---	---	---	---	---	---	---	
				BHP	0.27	0.29	0.29	0.30	0.32	0.32	0.34	0.35	0.35	---	---	---	---	---	---	---	---	---	---	---	
				Heating Rise (°F)	NA	NA	NA	NA	31	34	37	42	48	NA	NA	NA	NA	NA	NA	NA	NA	NA	NA	NA	
				Heating Rise (°C)	NA	NA	NA	NA	17	19	20	23	27	NA	NA	NA	NA	NA	NA	NA	NA	NA	NA	NA	
				CFM	756	669	548	457	---	---	---	---	---	---	---	---	---	---	---	---	---	---	---	---	---
				WATTS	84	90	96	106	---	---	---	---	---	---	---	---	---	---	---	---	---	---	---	---	---
				BHP	0.09	0.10	0.10	0.11	---	---	---	---	---	---	---	---	---	---	---	---	---	---	---	---	---
				Heating Rise (°C)	NA	NA	NA	NA	NA	NA	NA	NA	NA	NA	NA	NA	NA	NA	NA	NA	NA	NA	NA	NA	
30060	25 - 55°F (14 - 31°C)	Med-Low	Pink	Heating Rise (°C)	NA	NA	NA	NA	NA	NA	NA	NA	NA	NA	NA	NA	NA	NA	NA	NA	NA				
				CFM	1002	928	842	733	660	560	450	---	---	---	---	---	---	---	---	---	---	---	---		
				WATTS	144	155	161	173	185	192	203	---	---	---	---	---	---	---	---	---	---	---	---	---	
				BHP	0.15	0.17	0.17	0.19	0.20	0.21	0.22	---	---	---	---	---	---	---	---	---	---	---	---	---	
				Heating Rise (°F)	44	48	53	NA	NA	NA	NA	NA	NA	NA	NA	NA	NA	NA	NA	NA	NA	NA	NA	NA	
				Heating Rise (°C)	25	27	29	NA	NA	NA	NA	NA	NA	NA	NA	NA	NA	NA	NA	NA	NA	NA	NA	NA	
		Medium	Red	CFM	1110	1025	967	879	814	706	611	509	461	---	---	---	---	---	---	---	---	---	---	---	
				WATTS	188	195	205	211	223	236	243	255	243	---	---	---	---	---	---	---	---	---	---	---	
				BHP	0.20	0.21	0.22	0.23	0.24	0.25	0.26	0.27	0.26	---	---	---	---	---	---	---	---	---	---	---	
				Heating Rise (°F)	40	43	46	51	55	NA	NA	NA	NA	NA	NA	NA	NA	NA	NA	NA	NA	NA	NA	NA	
				Heating Rise (°C)	22	24	26	28	30	NA	NA	NA	NA	NA	NA	NA	NA	NA	NA	NA	NA	NA	NA	NA	
				CFM	1160	1091	1004	945	866	804	699	615	496	---	---	---	---	---	---	---	---	---	---	---	---
				WATTS	213	225	232	243	249	261	273	285	291	---	---	---	---	---	---	---	---	---	---	---	---
				BHP	0.23	0.24	0.25	0.26	0.27	0.28	0.29	0.31	0.31	---	---	---	---	---	---	---	---	---	---	---	---
30060	25 - 55°F (14 - 31°C)	Med-High ²	Orange	Heating Rise (°F)	38	41	44	47	51	55	NA	NA	NA	NA	NA	NA	NA	NA	NA	NA	NA				
				Heating Rise (°C)	21	23	25	26	29	31	NA	NA	NA	NA	NA	NA	NA	NA	NA	NA	NA	NA			
				CFM	1240	1173	1110	1031	966	902	821	726	626	---	---	---	---	---	---	---	---	---	---	---	
				WATTS	254	266	274	284	295	302	315	327	331	---	---	---	---	---	---	---	---	---	---	---	
				BHP	0.27	0.29	0.29	0.30	0.32	0.32	0.34	0.35	0.35	---	---	---	---	---	---	---	---	---	---	---	
				Heating Rise (°C)	36	38	40	43	46	49	54	NA	NA	NA	NA	NA	NA	NA	NA	NA	NA	NA	NA		
		High ¹	Black	Heating Rise (°F)	20	21	22	24	26	27	30	---	---	---	---	---	---	---	---	---	---	---	---		
				Heating Rise (°C)	20	21	22	24	26	27	30	---	---	---	---	---	---	---	---	---	---	---	---		

Dry Coil Air Delivery – Downflow Discharge 3 Phase Models Only (Cont.)

Unit	Heating Rise Range	Motor Speed	Wire Color	External Static Pressure (IN. W.C.)										
				0.1	0.2	0.3	0.4	0.5	0.6	0.7	0.8	0.9	1.0	
36060	25 - 55°F (14 - 31°C)	Low ¹	Blue	CFM	1277	1215	1147	1094	1045	992	932	874	826	757
				WATTS	285	289	299	305	314	319	328	335	347	352
				BHP	0.31	0.31	0.32	0.33	0.34	0.35	0.36	0.37	0.38	
				Heating Rise (°F)	35	37	39	41	43	45	48	51	54	
				Heating Rise (°C)	19	20	22	23	24	25	26	28	30	
				CFM	1312	1260	1203	1153	1095	1050	995	943	889	829
		Med-Low	Pink	WATTS	314	324	329	340	344	355	361	372	382	387
				BHP	0.34	0.35	0.35	0.36	0.37	0.38	0.39	0.40	0.41	
				Heating Rise (°F)	34	35	37	39	41	42	45	47	50	
				Heating Rise (°C)	19	20	21	21	23	24	25	26	28	
				CFM	1381	1326	1269	1212	1161	1121	1070	1019	974	912
				WATTS	358	365	375	383	391	395	406	418	424	434
36090	35 - 65°F (19 - 36°C)	Medium ²	Red	BHP	0.38	0.39	0.40	0.41	0.42	0.42	0.44	0.45	0.45	0.47
				Heating Rise (°F)	32	34	35	37	38	40	42	44	46	
				Heating Rise (°C)	18	19	19	20	21	22	23	24	25	
				CFM	1631	1579	1525	1477	1423	1372	1336	1284	1233	1166
				WATTS	567	576	581	592	598	609	617	619	613	598
				BHP	0.61	0.62	0.62	0.63	0.64	0.65	0.66	0.66	0.66	0.64
		Med-High	Orange	Heating Rise (°F)	27	28	29	30	31	32	33	35	36	38
				Heating Rise (°C)	15	16	16	17	17	18	18	19	20	21
				CFM	1681	1633	1575	1526	1478	1415	1366	1312	1249	1159
				WATTS	618	626	636	644	652	653	649	642	627	602
				BHP	0.66	0.67	0.68	0.69	0.70	0.70	0.70	0.69	0.67	0.65
				Heating Rise (°F)	26	27	28	29	30	31	33	34	36	38
36090	35 - 65°F (19 - 36°C)	High	Black	Heating Rise (°C)	15	15	16	16	17	17	18	19	20	21
				CFM	1277	1215	1147	1094	1045	992	932	874	826	757
				WATTS	285	289	299	305	314	319	328	335	347	352
				BHP	0.31	0.31	0.32	0.33	0.34	0.34	0.35	0.36	0.37	0.38
				Heating Rise (°F)	53	56	59	62	65	NA	NA	NA	NA	NA
				Heating Rise (°C)	30	31	33	35	36	NA	NA	NA	NA	NA
		Med-Low	Pink	CFM	1312	1260	1203	1153	1095	1050	995	943	889	829
				WATTS	314	324	329	340	344	355	361	372	382	387
				BHP	0.34	0.35	0.35	0.36	0.37	0.38	0.39	0.40	0.41	
				Heating Rise (°F)	52	54	57	59	62	65	NA	NA	NA	NA
				Heating Rise (°C)	29	30	31	33	35	36	NA	NA	NA	NA
				CFM	1381	1326	1269	1212	1161	1121	1070	1019	974	912
Medium ²	Red	WATTS	358	365	375	383	391	395	406	418	424	434		
		BHP	0.38	0.39	0.40	0.41	0.42	0.42	0.44	0.45	0.45	0.47		
		Heating Rise (°F)	49	51	54	56	59	61	64	NA	NA	NA		
		Heating Rise (°C)	27	28	30	31	33	34	35	NA	NA	NA		
		CFM	1631	1579	1525	1477	1423	1372	1336	1284	1233	1166		
		WATTS	567	576	581	592	598	609	617	619	613	598		
Med-High	Orange	BHP	0.61	0.62	0.62	0.63	0.64	0.65	0.66	0.66	0.66	0.64		
		Heating Rise (°F)	42	43	45	46	48	50	51	53	55			
		Heating Rise (°C)	23	24	25	26	27	28	28	29	31			
		CFM	1681	1633	1575	1526	1478	1415	1366	1312	1249	1159		
		WATTS	618	626	636	644	652	653	649	642	627	602		
		BHP	0.66	0.67	0.68	0.69	0.70	0.70	0.70	0.69	0.67	0.65		
High ¹	Black	Heating Rise (°F)	40	42	43	45	46	48	50	52	54			
		Heating Rise (°C)	22	23	24	25	26	27	28	29	30			

Dry Coil Air Delivery – Downflow Discharge 3 Phase Models Only (Cont.)

Unit	Heating Rise Range	Motor Speed	Wire Color	External Static Pressure (IN. W.C.)											
				0.1	0.2	0.3	0.4	0.5	0.6	0.7	0.8	0.9	1.0		
42060	25 - 55°F (14 - 31°C)	Low ¹	Blue	CFM	1365	1324	1284	1233	1181	1127	1084	1039	984	939	
				WATTS	177	189	201	210	222	236	248	261	269	281	
				Heating Rise (°F)	0.19	0.20	0.22	0.23	0.24	0.25	0.27	0.28	0.29	0.30	
		Med-Low	Pink	CFM	1425	1384	1339	1301	1254	1199	1151	1104	1065	1015	
				WATTS	197	210	223	235	248	257	271	284	296	305	
				Heating Rise (°F)	0.21	0.23	0.24	0.25	0.27	0.28	0.29	0.30	0.32	0.33	
	42090	35 - 65°F (19 - 36°C)	Medium	Red	CFM	1582	1549	1509	1469	1433	1392	1346	1300	1249	1213
					WATTS	267	280	294	308	322	336	344	359	374	387
					Heating Rise (°F)	0.29	0.30	0.32	0.33	0.35	0.36	0.37	0.38	0.40	0.42
			Med-High ²	Orange	CFM	1623	1586	1553	1511	1470	1433	1393	1350	1309	1261
					WATTS	285	299	312	324	335	349	363	378	393	407
					Heating Rise (°F)	0.31	0.32	0.33	0.35	0.36	0.37	0.39	0.41	0.42	0.44
42090	35 - 65°F (19 - 36°C)	High	Black	CFM	1775	1736	1696	1660	1622	1588	1557	1516	1472	1426	
				WATTS	371	386	401	410	424	439	453	468	483	497	
				Heating Rise (°F)	0.40	0.41	0.43	0.44	0.45	0.47	0.49	0.50	0.52	0.53	
		Low	Blue	CFM	1365	1324	1284	1233	1181	1127	1084	1039	984	939	
				WATTS	177	189	201	210	222	236	248	261	269	281	
				Heating Rise (°F)	0.19	0.20	0.22	0.23	0.24	0.25	0.27	0.28	0.29	0.30	
42090	35 - 65°F (19 - 36°C)	Med-Low	Pink	CFM	1425	1384	1339	1301	1254	1199	1151	1104	1065	1015	
				WATTS	197	210	223	235	248	257	271	284	296	305	
				Heating Rise (°F)	0.21	0.23	0.24	0.25	0.27	0.28	0.29	0.30	0.32	0.33	
		Medium ¹	Red	CFM	1582	1549	1509	1469	1433	1392	1346	1300	1249	1213	
				WATTS	267	280	294	308	322	336	344	359	374	387	
				Heating Rise (°F)	0.29	0.30	0.32	0.33	0.35	0.36	0.37	0.38	0.40	0.42	
42090	35 - 65°F (19 - 36°C)	Med-High ²	Orange	CFM	1623	1586	1553	1511	1470	1433	1393	1350	1309	1261	
				WATTS	285	299	312	324	335	349	363	378	393	407	
				Heating Rise (°F)	0.31	0.32	0.33	0.35	0.36	0.37	0.39	0.41	0.42	0.44	
		High	Black	CFM	1775	1736	1696	1660	1622	1588	1557	1516	1472	1426	
				WATTS	371	386	401	410	424	439	453	468	483	497	
				Heating Rise (°F)	0.40	0.41	0.43	0.44	0.45	0.47	0.49	0.50	0.52	0.53	

Dry Coil Air Delivery – Downflow Discharge 3 Phase Models Only (Cont.)

Unit	Heating Rise Range	Motor Speed	Wire Color	External Static Pressure (IN. W.C.)												
				0.1	0.2	0.3	0.4	0.5	0.6	0.7	0.8	0.9	1.0			
48090	35 - 65°F (19 - 36°C)	Low ¹	Blue	CFM	1503	1457	1423	1374	1330	1287	1241	1199	1153	1111		
				WATTS	225	233	246	254	269	282	292	307	314	329		
				BHP	0.24	0.25	0.26	0.27	0.29	0.30	0.31	0.33	0.34	0.35		
				Heating Rise (°F)	45	47	48	49	51	53	55	57	59	61		
		Med-Low	Pink	Medium ²	Red	CFM	1556	1508	1461	1432	1388	1346	1302	1256	1221	1168
						WATTS	244	261	268	281	290	305	319	330	345	353
						BHP	0.26	0.28	0.29	0.30	0.31	0.33	0.34	0.35	0.37	0.38
						Heating Rise (°F)	44	45	47	47	49	51	52	54	56	58
		Med-High	Orange	High	Black	CFM	1861	1822	1786	1758	1716	1688	1660	1619	1583	1539
						WATTS	400	417	426	441	452	467	482	492	507	519
						BHP	0.43	0.45	0.46	0.47	0.48	0.50	0.52	0.53	0.54	0.56
						Heating Rise (°F)	37	37	38	39	40	40	41	42	43	44
		48115	30 - 60°F (17 - 33°C)	Low	Blue	CFM	2014	1922	1861	1799	1730	1666	1600	1533	1466	1400
						WATTS	758	769	787	799	808	823	822	805	780	737
BHP	0.81					0.82	0.84	0.86	0.87	0.88	0.88	0.86	0.84	0.79		
Heating Rise (°F)	NA					NA	NA	NA	NA	NA	NA	NA	NA	NA		
Med-Low	Pink			Medium ²	Orange	CFM	2532	2487	2444	2391	2330	2259	2179	2111	2033	1949
						WATTS	1014	1022	1015	994	965	935	898	858	823	786
						BHP	1.09	1.10	1.09	1.07	1.03	1.00	0.96	0.92	0.88	0.84
						Heating Rise (°F)	NA	NA	NA	NA	NA	NA	NA	NA	NA	NA
Med-High ¹	Black			High	Black	CFM	1503	1457	1423	1374	1330	1287	1241	1199	1153	1111
						WATTS	225	233	246	254	269	282	292	307	314	329
						BHP	0.24	0.25	0.26	0.27	0.29	0.30	0.31	0.33	0.34	0.35
						Heating Rise (°F)	58	60	NA	NA	NA	NA	NA	NA	NA	NA
48115	30 - 60°F (17 - 33°C)			Low	Blue	CFM	1556	1508	1461	1432	1388	1346	1302	1256	1221	1168
						WATTS	244	261	268	281	290	305	319	330	345	353
		BHP	0.26			0.28	0.29	0.30	0.31	0.33	0.34	0.35	0.37	0.38		
		Heating Rise (°F)	56			58	59	NA	NA	NA	NA	NA	NA	NA		
		Med-Low	Pink	Medium ²	Orange	CFM	1861	1822	1786	1758	1716	1688	1660	1619	1583	1539
						WATTS	400	417	426	441	452	467	482	492	507	519
						BHP	0.43	0.45	0.46	0.47	0.48	0.50	0.52	0.53	0.54	0.56
						Heating Rise (°F)	47	48	49	49	51	51	52	54	55	56
		Med-High ¹	Black	High	Black	CFM	2319	2291	2255	2230	2193	2166	2118	2057	1992	1887
						WATTS	758	769	787	799	808	823	822	805	780	737
						BHP	0.81	0.82	0.84	0.86	0.87	0.88	0.88	0.86	0.84	0.79
						Heating Rise (°F)	37	38	39	39	40	40	41	42	44	46

Dry Coil Air Delivery – Downflow Discharge 3 Phase Models Only (Cont.)

Unit	Heating Rise Range	Motor Speed	Wire Color	External Static Pressure (IN. W.C.)											
				0.1	0.2	0.3	0.4	0.5	0.6	0.7	0.8	0.9	1.0		
48130	35 - 65°F (19 - 36°C)	Low	Blue	CFM	1503	1457	1423	1374	1330	1287	1241	1199	1153	1111	
				WATTS	225	233	246	254	269	282	292	307	314	329	
				BHP	0.24	0.25	0.26	0.27	0.29	0.30	0.31	0.33	0.34	0.35	
				Heating Rise (°F)	64	NA	NA	NA	NA	NA	NA	NA	NA	NA	NA
				Heating Rise (°C)	36	NA	NA	NA	NA	NA	NA	NA	NA	NA	NA
				CFM	1556	1508	1461	1432	1388	1346	1302	1256	1221	1168	
		Med-Low	Pink	WATTS	244	261	268	281	290	305	319	330	345	353	
				BHP	0.26	0.28	0.29	0.30	0.31	0.33	0.34	0.35	0.37	0.38	
				Heating Rise (°F)	62	64	NA	NA	NA	NA	NA	NA	NA	NA	
				Heating Rise (°C)	34	35	NA	NA	NA	NA	NA	NA	NA	NA	
				CFM	1861	1822	1786	1758	1716	1688	1660	1619	1583	1539	
				WATTS	400	417	426	441	452	467	482	492	507	519	
		Medium ²	Red	BHP	0.43	0.45	0.46	0.47	0.48	0.50	0.52	0.53	0.54	0.56	
				Heating Rise (°F)	52	53	54	55	56	57	58	59	61	63	
Heating Rise (°C)	29			29	30	30	31	32	32	33	34	35			
CFM	2319			2291	2255	2230	2193	2166	2118	2057	1992	1887			
WATTS	758			769	787	799	808	823	822	805	780	737			
BHP	0.81			0.82	0.84	0.86	0.87	0.88	0.88	0.86	0.84	0.79			
Med-High ¹	Orange	Heating Rise (°F)	42	42	43	43	44	44	45	47	48	51			
		Heating Rise (°C)	23	23	24	24	24	25	25	26	27	28			
		CFM	2532	2487	2444	2391	2330	2259	2179	2111	2033	1949			
		WATTS	1014	1022	1015	994	965	935	898	858	823	786			
		BHP	1.09	1.10	1.09	1.07	1.03	1.00	0.96	0.92	0.88	0.84			
		Heating Rise (°C)	38	39	39	40	41	43	44	46	47	49			
60090	35 - 65°F (19 - 36°C)	High	Black	CFM	1479	1436	1387	1346	1298	1253	1206	1160	1114	1061	
				WATTS	224	239	247	262	270	284	300	307	319	330	
				BHP	0.24	0.26	0.26	0.28	0.29	0.30	0.32	0.33	0.34	0.35	
				Heating Rise (°F)	46	47	49	51	52	54	56	59	61	64	
				Heating Rise (°C)	26	26	27	28	29	30	31	33	34	36	
				CFM	1841	1796	1761	1724	1690	1651	1616	1578	1527	1478	
		Med-Low	Pink	WATTS	425	434	453	460	476	485	501	508	525	542	
				BHP	0.46	0.47	0.49	0.49	0.51	0.52	0.54	0.54	0.56	0.58	
				Heating Rise (°F)	37	38	39	39	40	41	42	43	45	46	
				Heating Rise (°C)	21	21	21	22	22	23	23	24	25	26	
				CFM	1944	1913	1872	1838	1801	1771	1731	1698	1655	1613	
				WATTS	486	501	511	529	537	554	565	578	595	603	
		Medium ²	Red	BHP	0.52	0.54	0.55	0.57	0.58	0.59	0.61	0.62	0.64	0.65	
				Heating Rise (°F)	35	36	36	37	38	38	39	40	41	42	
Heating Rise (°C)	19			20	20	21	21	21	22	22	23	23			
CFM	2178			2148	2105	2073	2036	2002	1967	1919	1845	1751			
WATTS	674			691	703	717	733	743	758	754	734	701			
BHP	0.72			0.74	0.75	0.77	0.79	0.80	0.81	0.81	0.79	0.75			
Med-High	Orange	Heating Rise (°F)	NA	NA	NA	NA	NA	NA	NA	35	35	37	39		
		Heating Rise (°C)	NA	NA	NA	NA	NA	NA	NA	19	20	20	22		
		CFM	2480	2432	2375	2322	2236	2161	2085	2006	1917	1808			
		WATTS	1029	1012	995	975	941	908	869	836	796	751			
		BHP	1.10	1.09	1.07	1.05	1.01	0.97	0.93	0.90	0.85	0.81			
		Heating Rise (°C)	NA	NA	NA	NA	NA	NA	NA	NA	35	38			
High	Black	Heating Rise (°C)	NA	NA	NA	NA	NA	NA	NA	NA	NA	20	21		
		Heating Rise (°C)	NA	NA	NA	NA	NA	NA	NA	NA	NA	20	21		

Dry Coil Air Delivery – Downflow Discharge 3 Phase Models Only (Cont.)

Unit	Heating Rise Range	Motor Speed	Wire Color	External Static Pressure (IN. W.C.)											
				0.1	0.2	0.3	0.4	0.5	0.6	0.7	0.8	0.9	1.0		
60115	30 - 60°F (17 - 33°C)	Low	Blue	CFM	1479	1436	1387	1346	1298	1253	1206	1160	1114	1061	
				WATTS	224	239	247	262	270	284	300	307	319	330	
				BHP	0.24	0.26	0.26	0.28	0.29	0.30	0.32	0.33	0.34	0.35	
		Med-Low	Pink	Heating Rise (°F)	59	NA	NA	NA	NA	NA	NA	NA	NA	NA	NA
				Heating Rise (°C)	33	NA	NA	NA	NA	NA	NA	NA	NA	NA	NA
				CFM	1841	1796	1761	1724	1690	1651	1616	1578	1527	1478	
		Medium ²	Red	WATTS	425	434	453	460	476	485	501	508	525	542	
				BHP	0.46	0.47	0.49	0.49	0.51	0.52	0.54	0.54	0.56	0.58	
				Heating Rise (°F)	47	48	49	50	51	53	54	55	57	59	
		Med-High ¹	Orange	Heating Rise (°C)	26	27	27	28	29	29	30	31	32	33	
				CFM	1944	1913	1872	1838	1801	1771	1731	1698	1655	1613	
				WATTS	486	501	511	529	537	554	565	578	595	603	
		High	Black	BHP	0.52	0.54	0.55	0.57	0.58	0.59	0.61	0.62	0.64	0.65	
				Heating Rise (°F)	45	45	46	47	48	49	50	51	53	54	
				Heating Rise (°C)	25	25	26	26	27	27	28	28	29	30	
60130	35 - 65°F (19 - 36°C)	Low	Blue	CFM	2148	2148	2105	2073	2036	2002	1967	1919	1845	1751	
				WATTS	674	691	703	717	733	743	758	754	734	701	
				BHP	0.72	0.74	0.75	0.77	0.79	0.80	0.81	0.81	0.79	0.75	
		Med-Low	Pink	Heating Rise (°F)	40	40	41	42	43	43	44	45	47	50	
				Heating Rise (°C)	22	22	23	23	24	24	25	25	26	28	
				CFM	2480	2432	2375	2322	2236	2161	2085	2006	1917	1808	
		Medium ²	Red	WATTS	1029	1012	995	975	941	908	869	836	796	751	
				BHP	1.10	1.09	1.07	1.05	1.01	0.97	0.93	0.90	0.85	0.81	
				Heating Rise (°F)	35	36	37	37	39	40	42	43	45	48	
		Med-High ¹	Orange	Heating Rise (°C)	19	20	20	21	22	22	23	24	25	27	
				CFM	1479	1436	1387	1346	1298	1253	1206	1160	1114	1061	
				WATTS	224	239	247	262	270	284	300	307	319	330	
		High	Black	BHP	0.24	0.26	0.26	0.28	0.29	0.30	0.32	0.33	0.34	0.35	
				Heating Rise (°F)	65	NA	NA	NA	NA	NA	NA	NA	NA	NA	
				Heating Rise (°C)	36	NA	NA	NA	NA	NA	NA	NA	NA	NA	
60130	35 - 65°F (19 - 36°C)	Low	Blue	CFM	1841	1796	1761	1724	1690	1651	1616	1578	1527	1478	
				WATTS	425	434	453	460	476	485	501	508	525	542	
				BHP	0.46	0.47	0.49	0.49	0.51	0.52	0.54	0.54	0.56	0.58	
		Med-Low	Pink	Heating Rise (°F)	52	54	55	56	57	58	60	61	63	65	
				Heating Rise (°C)	29	30	30	31	32	32	33	34	35	36	
				CFM	1944	1913	1872	1838	1801	1771	1731	1698	1655	1613	
		Medium ²	Red	WATTS	486	501	511	529	537	554	565	578	595	603	
				BHP	0.52	0.54	0.55	0.57	0.58	0.59	0.61	0.62	0.64	0.65	
				Heating Rise (°F)	50	50	51	52	53	54	56	57	58	60	
		Med-High ¹	Orange	Heating Rise (°C)	28	28	29	29	30	30	31	32	32	33	
				CFM	2178	2148	2105	2073	2036	2002	1967	1919	1845	1751	
				WATTS	674	691	703	717	733	743	758	754	734	701	
		High	Black	BHP	0.72	0.74	0.75	0.77	0.79	0.80	0.81	0.81	0.79	0.75	
				Heating Rise (°F)	44	45	46	46	47	48	49	50	52	55	
				Heating Rise (°C)	25	25	25	26	26	27	27	28	29	31	
High	Black	CFM	2480	2432	2375	2322	2236	2161	2085	2006	1917	1808			
		WATTS	1029	1012	995	975	941	908	869	836	796	751			
		BHP	1.10	1.09	1.07	1.05	1.01	0.97	0.93	0.90	0.85	0.81			
High	Black	Heating Rise (°F)	39	40	41	41	43	45	46	48	50	53			
		Heating Rise (°C)	22	22	23	23	24	25	26	27	28	30			

See Legend and Notes on following page.

34 *Air delivery values are without air filter and are for dry coil (See Wet Coil Pressure Drop table).

- 1 Factory-shipped heating speed
- 2 Factory-shipped cooling speed

"NA" = Not allowed for heating speed

NOTE: Ducted field-supplied air filter pressure drop and wet coil pressure drop to obtain external static pressure available for ducting. Shaded areas indicate speed/static combinations that are not permitted for dehumidification speed.

Wet Coil Pressure Drop (IN. W.C.)

UNIT SIZE	STANDARD CFM (SCFM)																
	600	700	800	900	1000	1100	1200	1300	1400	1500	1600	1700	1800	1900	2000	2100	2200
24	0.03	0.04	0.04	0.05	0.06												
30				0.05	0.06	0.07	0.08	0.11									
36				0.06	0.06	0.09	0.10	0.11	0.14								
42					0.05	0.05	0.06	0.07	0.08	0.08	0.09	0.09	0.11				
48							0.04	0.06	0.09	0.10	0.10	0.11	0.12	0.13	0.14		
60								0.06	0.09	0.06	0.07	0.01	0.08	0.09	0.10	0.12	0.13

Economizer with 1-in. Filter Pressure Drop (IN. W.C.)

FILTER SIZE IN. (MM)	COOLING TONS	STANDARD CFM (SCFM)																
		600	700	800	900	1000	1100	1200	1300	1400	1500	1600	1700	1800	1900	2000	2100	2200
600-1400 CFM 12x20x1+12x20x1 (305x508x25+305x508x25)	2.0,	-	-	0.09	0.14	0.16	0.18	0.25	0.28	0.30	-	-	-	-	-	-	-	-
	2.5,																	
	3.0																	
1200-1800 CFM 16x24x1+14x24x1 (406x610x25+356x610x25)	3.5,	-	-	-	-	-	-	0.10	0.11	0.12	0.13	0.14	0.16	0.16	-	-	-	-
	4.0																	
1500-2200 CFM 16x24x1+18x24x1 (406x610x25+457x610x25)	5.0	-	-	-	-	-	-	-	-	-	0.15	0.17	0.18	0.20	0.21	0.22	0.23	0.23

Filter Pressure Drop Table (IN. W.C.)

FILTER SIZE IN. (MM)	COOLING TONS	STANDARD CFM (SCFM)																
		600	700	800	900	1000	1100	1200	1300	1400	1500	1600	1700	1800	1900	2000	2100	2200
600-1400 CFM 12x20x1+12x20x1 (305x508x25+305x508x25)	2.0,	0.03	0.05	0.06	0.08	0.10	0.11	0.13	0.14	0.16	-	-	-	-	-	-	-	-
	2.5,																	
	3.0																	
1200-1800 CFM 16x24x1+14x24x1 (406x610x25+356x610x25)	3.5,	-	-	-	-	-	-	0.07	0.08	0.09	0.09	0.10	0.11	0.12	-	-	-	-
	4.0																	
1500-2200 CFM 16x24x1+18x24x1 (406x610x25+457x610x25)	5.0	-	-	-	-	-	-	-	-	-	0.04	0.06	0.08	0.10	0.11	0.13	0.14	0.15

TYPICAL PIPING AND WIRING

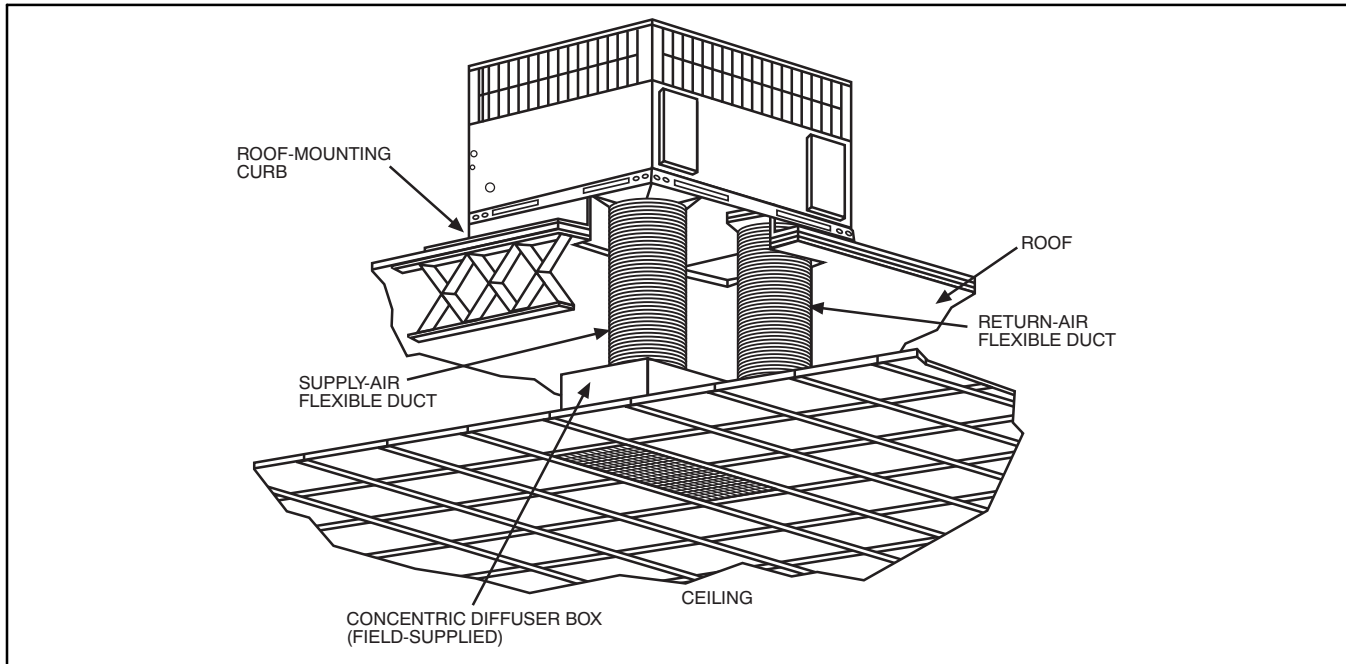

A09230

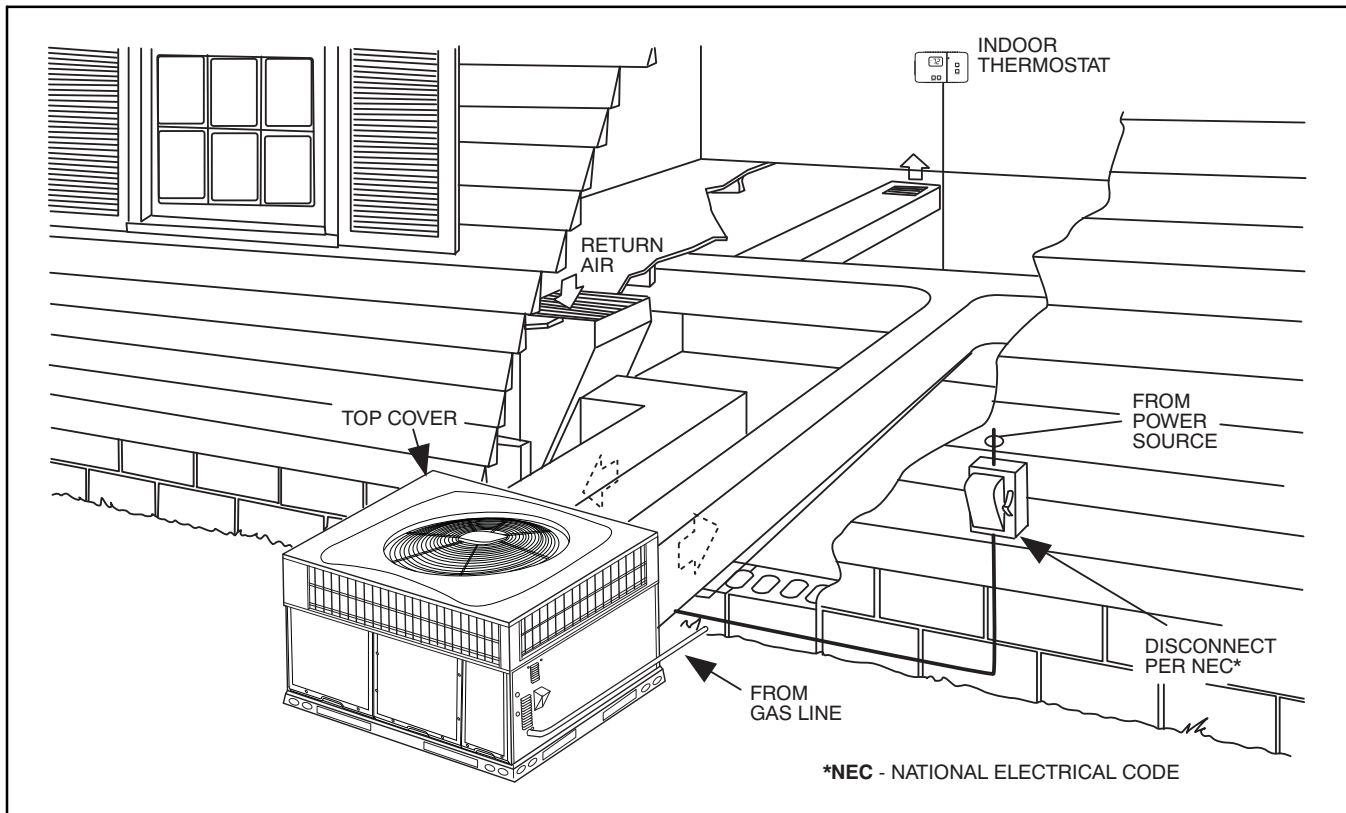

A09231

APPLICATION DATA

Condensate trap — A 2-in. (50.8 mm) condensate trap must be field supplied.

Ductwork — Secure downflow discharge ductwork to roof curb. For horizontal discharge applications, attach ductwork to unit with flanges.

To convert a unit to downflow discharge — Units are equipped with factory-installed inserts in the down-flow openings. Removal of the inserts is similar to removing an electrical knock-out. Use the duct cover to seal the horizontal discharge openings in the unit. Units installed in horizontal discharge orientation do not require duct covers.

Airflow — Units are draw-thru in the cooling mode and blow-thru in the heating mode.

Maximum cooling airflow — To minimize the possibility of condensate blow-off from the evaporator, airflow through the units should not exceed 450 cfm per ton.

Minimum cooling airflow — Minimum cooling airflow is 350 cfm per ton.

Minimum ambient cooling operation temperature — All standard units have a minimum ambient operating temperature of 40°F (4°C). With accessory low ambient temperature kit, units can operate at temperatures down to 0°F (-17°C).

Minimum temperature — Air entering the heat exchanger in heating mode must be a minimum of 50°F (10°C) continuous and/or 45°F (7°C) intermittent.

ELECTRICAL DATA

UNIT SIZE	NOMINAL V-PH-HZ	VOLTAGE RANGE		COMPRESSOR		OFM	IFM	IDM	POWER SUPPLY	
		MIN	MAX	RLA	LRA	FLA	FLA	FLA	MCA	MOCP
24040	208/230-1-60	197	253	13.5	58.3	0.7	4.1	0.65	21.7	30
24060				13.5	58.3	0.7	4.1	0.65	21.7	30
30040				12.8	64.0	0.7	4.1	0.65	20.8	30
30060				12.8	64.0	0.7	4.1	0.65	20.8	30
36060				14.1	77.0	1.2	6.0	0.65	24.8	35
36090				14.1	77.0	1.2	6.0	0.75	24.8	35
42060				17.9	112.0	1.2	6.0	0.65	29.6	40
42090				17.9	112.0	1.2	6.0	0.65	29.6	40
48090				21.8	117.0	1.2	7.6	0.65	36.1	50
48115				21.8	117.0	1.2	7.6	0.65	36.1	50
48130				21.8	117.0	1.2	7.6	0.75	36.1	50
60090				26.4	134.0	1.2	7.6	0.65	41.8	60
60115				26.4	134.0	1.2	7.6	0.65	41.8	60
60130				26.4	134.0	1.2	7.6	0.75	41.8	60
30040	208/230-3-60	197	253	8.3	58.0	0.7	4.1	0.65	15.2	20
30060				8.3	58.0	0.7	4.1	1.65	15.2	20
36060				9.0	71.0	1.2	6.0	1.65	18.5	25
36090				9.0	71.0	1.2	6.0	0.52	18.5	25
42060				13.5	88.0	1.2	6.0	1.65	24.1	35
42090				13.5	88.0	1.2	6.0	0.65	24.1	35
48090				13.7	83.1	1.2	7.6	0.65	25.9	35
48115				13.7	83.1	1.2	7.6	1.65	25.9	35
48130				13.7	83.1	1.2	7.6	0.52	25.9	35
60090				16.0	110.0	1.2	7.6	0.65	28.8	40
60115				16.0	110.0	1.2	7.6	1.65	28.8	40
60130				16.0	110.0	1.2	7.6	0.52	28.8	40
36060	460-3-60	414	506	5.6	38.0	0.5	3.0	0.70	10.5	15
36090				5.6	38.0	0.5	3.0	0.30	10.5	15
42060				6.0	44.0	0.5	3.0	0.70	11.0	15
42090				6.0	44.0	0.5	3.0	0.33	11.0	15
48090				6.2	41.0	0.5	3.8	0.33	12.1	15
48115				6.2	41.0	0.5	3.8	0.70	12.1	15
48130				6.2	41.0	0.5	3.8	0.30	12.1	15
60090				7.8	52.0	0.5	3.8	0.33	14.1	20
60115				7.8	52.0	0.5	3.8	0.70	14.1	20
60130				7.8	52.0	0.5	3.8	0.30	14.1	20

LEGEND

- FLA - Full Load Amps
- IDM - Inducer Motor
- IFM - Indoor Fan Motor
- LRA - Locked Rotor Amps
- MCA - Minimum Circuit Amps
- MOCP - Maximum Over Current Protection
- OFM - Outdoor Fan Motor
- RLA - Rated Load Amps

NOTES:

1. In compliance with NEC (National Electrical Code) requirements for multimotor and combination load equipment (refer to NEC Articles 430 and 440), the overcurrent protective device for the unit shall be Power Supply fuse or circuit breaker.
2. Minimum wire size is based on 60 C copper wire. If other than 60 C wire is used, or if length exceeds wire length in table, determine size from NEC.
3. Unbalanced 3-Phase Supply Voltage
Never operate a motor where a phase imbalance in supply voltage is greater than 2%. Use the following formula to determine the percentage of voltage imbalance

$$\% \text{ Voltage imbalance} = 100 \times \frac{\text{max voltage deviation from average voltage}}{\text{average voltage}}$$

EXAMPLE: Supply voltage is 230-3-60.

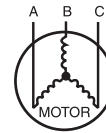

$$\begin{aligned} \text{AB} &= 228 \text{ v} \\ \text{BC} &= 231 \text{ v} \\ \text{AC} &= 227 \text{ v} \\ \text{Average Voltage} &= \frac{228 + 231 + 227}{3} \\ &= \frac{686}{3} \\ &= 229 \end{aligned}$$

Determine maximum deviation from average voltage.

$$\begin{aligned} \text{(AB)} \quad 229 - 228 &= 1 \text{ v} \\ \text{(BC)} \quad 231 - 229 &= 2 \text{ v} \\ \text{(AC)} \quad 229 - 227 &= 2 \text{ v} \end{aligned}$$

Maximum deviation is 2 v.

Determine percent of voltage imbalance

$$\begin{aligned} \% \text{ Voltage Imbalance} &= 100 \times \frac{2}{229} \\ &= 0.8\% \end{aligned}$$

This amount of phase imbalance is satisfactory as it is below the maximum allowable 2%.

IMPORTANT: If the supply voltage phase imbalance is more than 2%, contact your local electric utility company immediately.

CONNECTION WIRING SCHEMATIC 208/230-1-60

CONNECTION WIRING DIAGRAM DANGER: ELECTRICAL SHOCK HAZARD DISCONNECT POWER BEFORE SERVICING SCHEMATIC 208/230-1-60

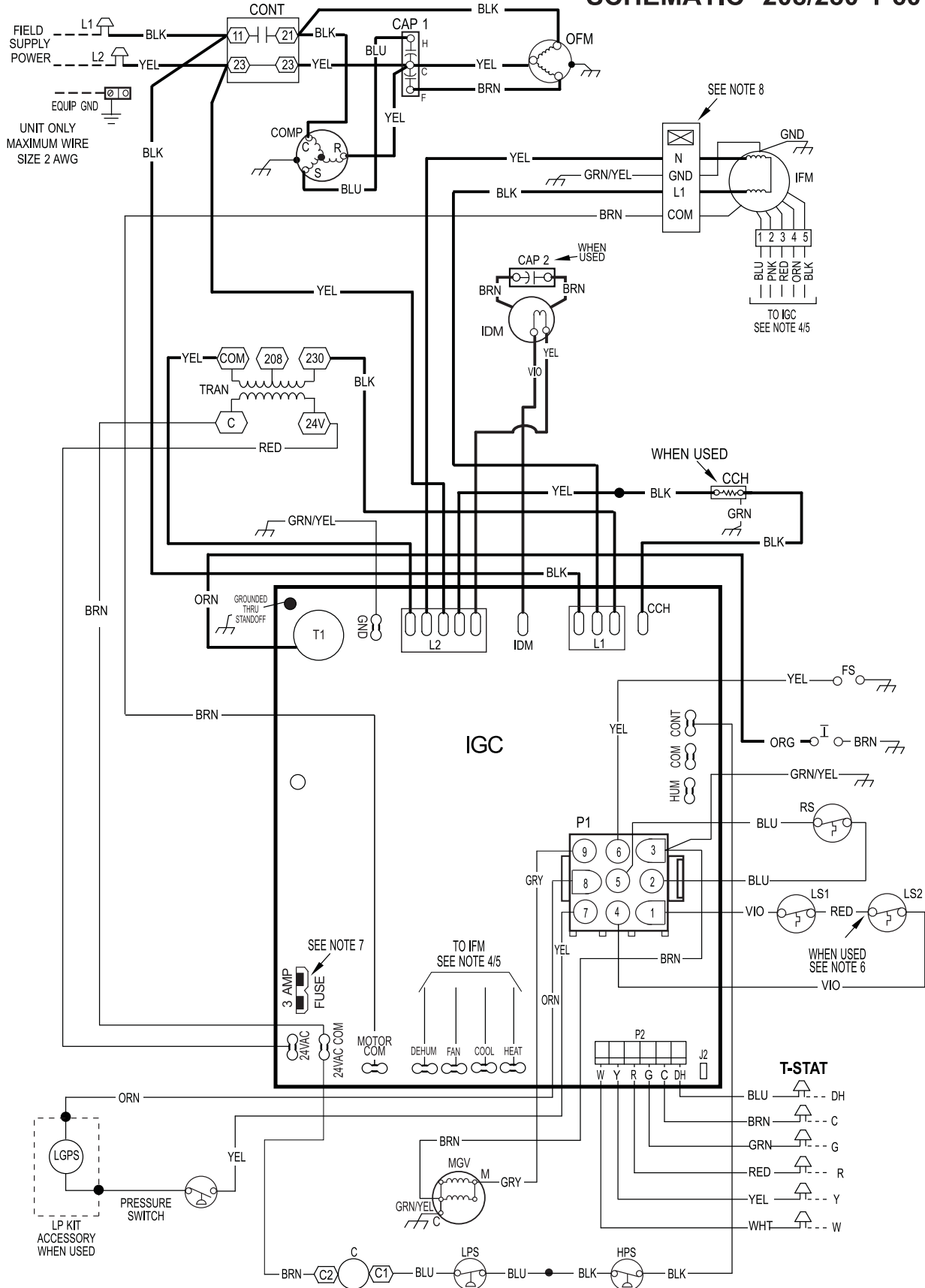

A14409

LADDER WIRING SCHEMATIC 208/230-1-60

LADDER WIRING DIAGRAM

DANGER: ELECTRICAL SHOCK HAZARD DISCONNECT POWER BEFORE SERVICING

LEGEND

	FIELD SPICE	EQUIP	EQUIPMENT
	TERMINAL (MARKED)	FS	FLAME SENSOR
	TERMINAL (UNMARKED)	GND	GROUND
	SPLICE	HPS	HIGH PRESSURE SWITCH
	SPLICE (MARKED)	I	IGNITOR
	FACTORY LO VOLTAGE	IDM	INDUCED DRAFT MOTOR
	FIELD CONTROL WIRING	IFM	INDOOR FAN MOTOR
	FIELD POWER WIRING	IGC	INTERGRATED GAS UNIT CONTROLLER
	ACCESSORY OR OPTIONAL WIRING	LGPS	LOW GAS PRESSURE SWITCH (WHEN USED)
	FACTORY HI VOLTAGE	LPS	LOW PRESSURE SWITCH
	CONTACTOR	LS1	PRIMARY LIMIT SWITCH
	CAPACITOR, COMP	LS2	SECONDARY LIMIT SWITCH
	CAPACITOR, INDUCER (WHEN USED)	MGV	MAIN GAS VALVE
	CRANKCASE HEATER	OFM	OUTDOOR FAN MOTOR
	COMPRESSOR MOTOR	OT	OUTDOOR FAN MOTOR
		RS	ROLLOUT SWITCH
		TRAN	TRANSFORMER
		T-STAT	THERMOSTAT

10 UNIT COMPONENT ARRANGEMENT

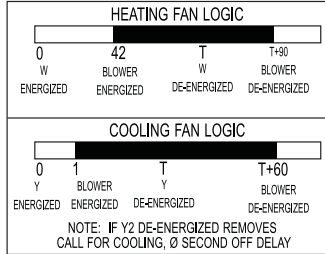
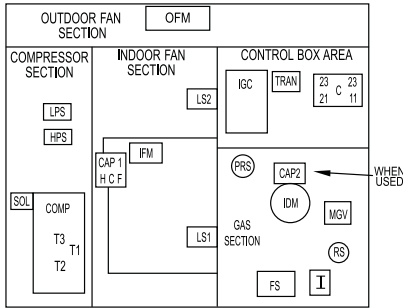

NOTES:

- IF ANY OF THE ORIGINAL WIRES FURNISHED ARE REPLACED THEY MUST BE REPLACED WITH THE SAME WIRE OR IT'S EQUIVALENT.
- SEE PRE-SALE LITERATURE FOR THERMOSTATS.
- USE 75 DEGREES C COPPER CONDUCTORS FOR FIELD INSTALLATION.
- REFER TO INSTALLATION INSTRUCTIONS FOR CORRECT SPEED SELECTION FOR IFM.
- SEE INSTALLATION INSTRUCTIONS FOR PROPER HEATING AND COOLING CONNECTIONS FOR YOUR UNIT.
- ON SOME MODELS LS1 AND LS2 ARE WIRED IN SERIES. ON OTHER MODELS ONLY LS1 IS USED.
- THIS FUSE IS MANUFACTURED BY LITTLE FUSE, PIN 257003.
- DO NOT DISCONNECT PLUG UNDER LOAD.
- N.E.C. CLASS 2, 24V.

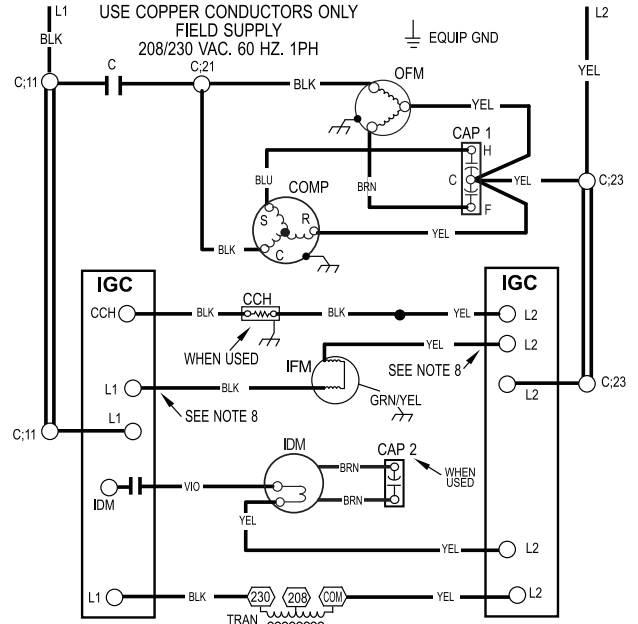

T-STAT

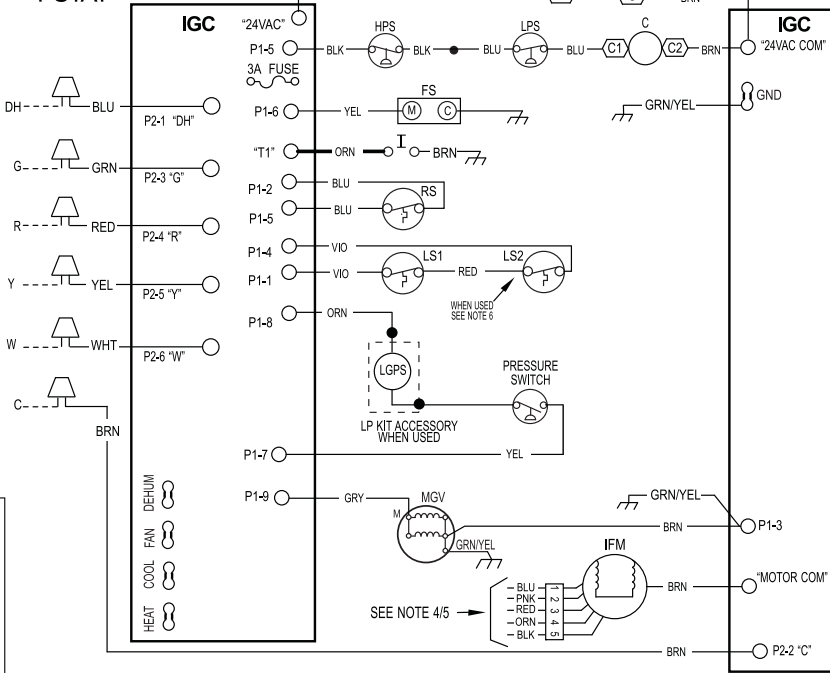

48VL500332 REV. A



A14410

CONNECTION WIRING DIAGRAM

DANGER: ELECTRICAL SHOCK HAZARD DISCONNECT POWER BEFORE SERVICING

NOTES:

1. IF ANY OF THE ORIGINAL WIRES FURNISHED ARE REPLACED, THEY MUST BE REPLACED WITH TYPE 90 DEG. C WIRE OR ITS EQUIVALENT.
2. SEE PRICE PAGES FOR THERMOSTAT AND SUBBASES.
3. USE 75 DEG. COPPER CONDUCTORS FOR FIELD INSTALLATION.
4. SEE INSTALLATION INSTRUCTIONS FOR PROPER HEATING AND COOLING CONNECTIONS FOR YOUR UNIT. INDOOR FAN MOTOR PLUGS - "DO NOT DISCONNECT UNDER LOAD"
5. LS2 USED ON SMALL CHASSIS ONLY.
6. INDUCER CAPACITOR AND WIRING ON CERTAIN MODELS ONLY. IF CAP2 IS PRESENT, YELLOW WIRES FROM IGC AND IDM CONNECT ON SAME SIDE OF CAP2.
7. THIS FUSE IS MANUFACTURED BY LITTELFUSE, P/N 257003.
8. THIS FUSE IS MANUFACTURED BY LITTELFUSE, P/N 257005.
9. DEHUMIDIFICATION FEATURE CANNOT BE USED WHEN ECONOMIZER IS INSTALLED.

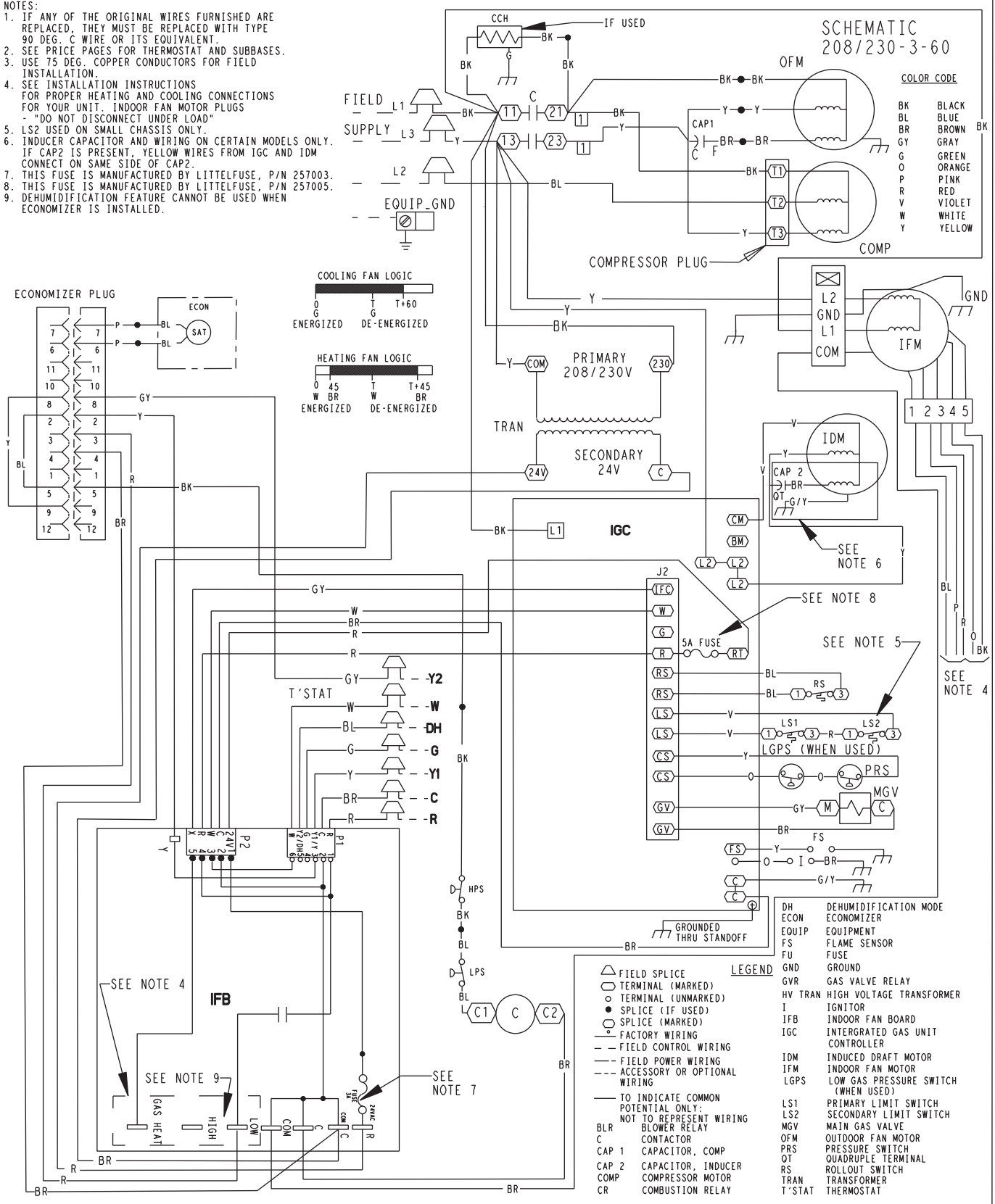

LADDER WIRING DIAGRAM

DANGER: ELECTRICAL SHOCK HAZARD DISCONNECT POWER BEFORE SERVICING

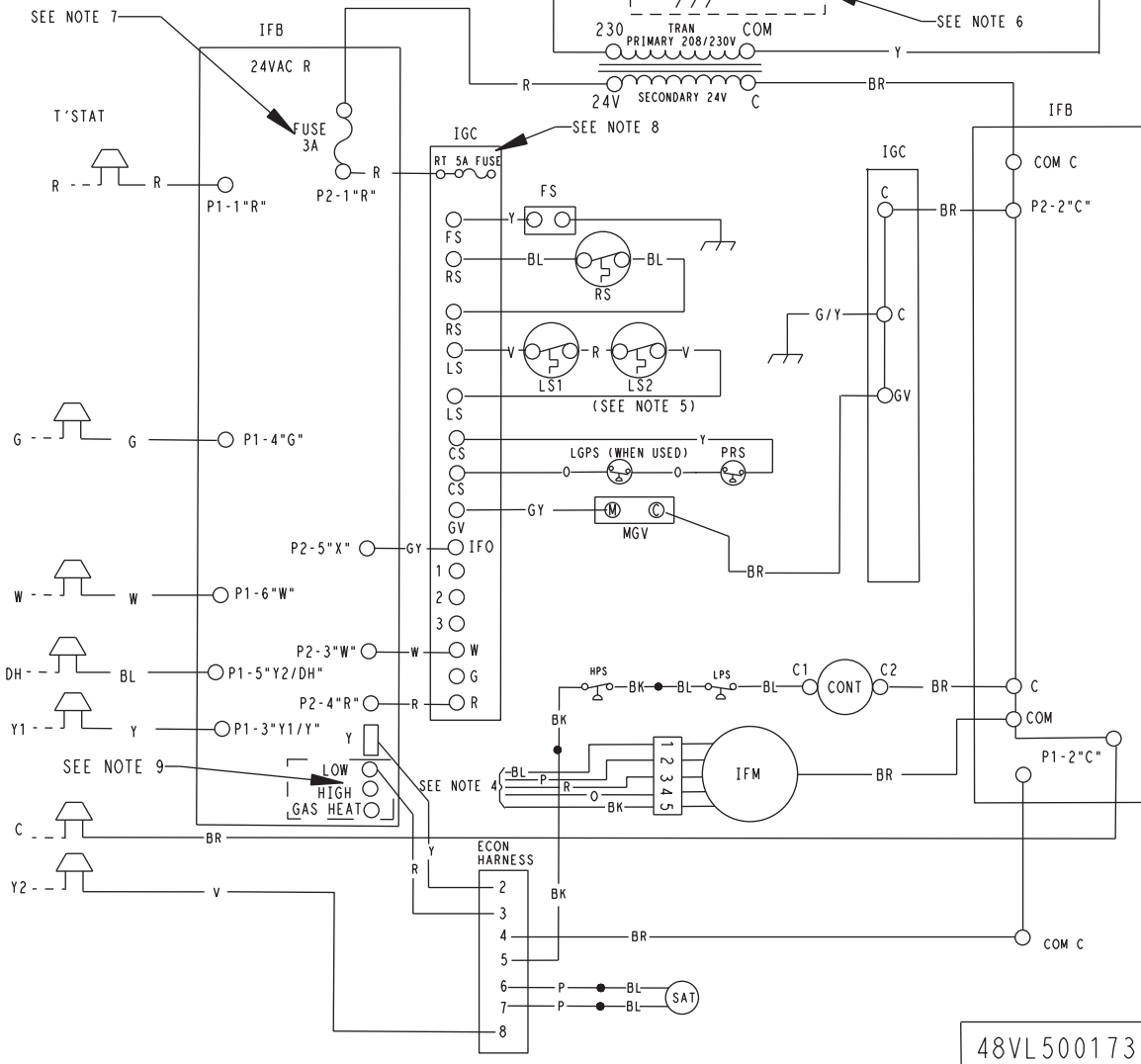
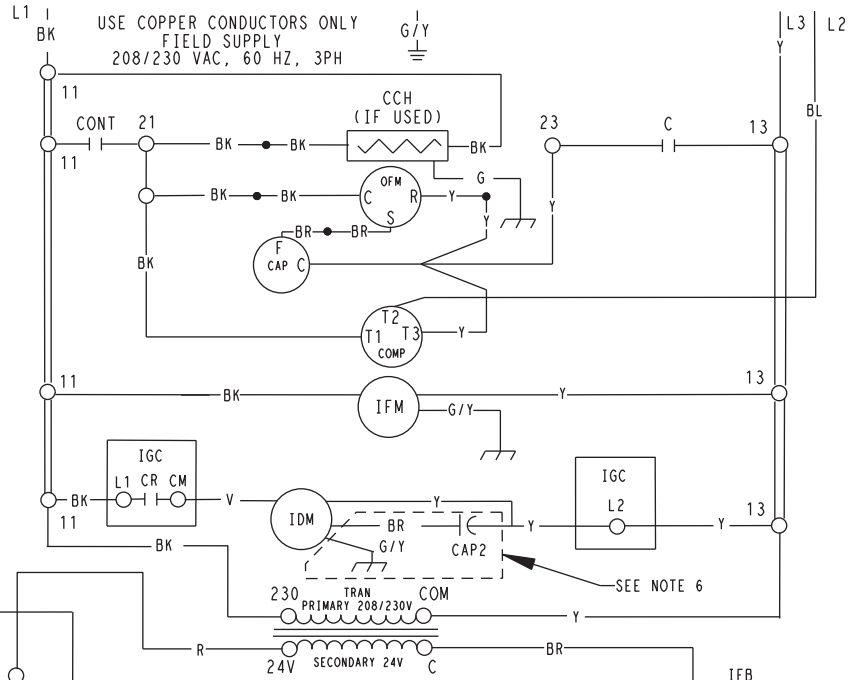
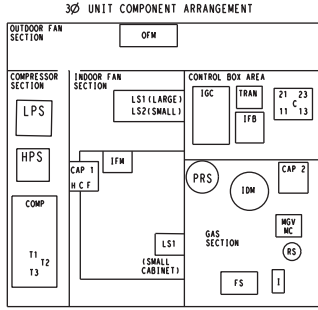

48VL500173 C

CONNECTION WIRING DIAGRAM

DANGER: ELECTRICAL SHOCK HAZARD DISCONNECT POWER BEFORE SERVICING

NOTES:

1. IF ANY OF THE ORIGINAL WIRES FURNISHED ARE REPLACED, THEY MUST BE REPLACED WITH TYPE 90 DEG. C WIRE OR ITS EQUIVALENT.
2. SEE PRICE PAGES FOR THERMOSTAT AND SUBBASES.
3. USE 75 DEG. COPPER CONDUCTORS FOR FIELD INSTALLATION.
4. SEE INSTALLATION INSTRUCTIONS FOR PROPER HEATING AND COOLING CONNECTIONS FOR YOUR UNIT. INDOOR FAN MOTOR PLUGS - "DO NOT DISCONNECT UNDER LOAD"
5. LS2 USED ON SMALL CHASSIS ONLY.
6. INDUCER CAPACITOR AND WIRING ON CERTAIN MODELS ONLY. IF CAP2 IS PRESENT, YELLOW WIRES FROM CONTACTOR AND IDM CONNECT ON SAME SIDE OF CAP2.
7. THIS FUSE IS MANUFACTURED BY LITTELFUSE, P/N 257003.
8. THIS FUSE IS MANUFACTURED BY LITTELFUSE, P/N 257005.
9. THESE FUSES ARE MANUFACTURED BY COOPER BUSSMAN, P/N FNG-R-5.
10. DEHUMIDIFICATION FEATURE CANNOT BE USED WHEN ECONOMIZER IS INSTALLED.

SCHEMATIC 460-3-60

COLOR CODE

BK	BLACK
BL	BLUE
BR	BROWN
GY	GRAY
G	GREEN
O	ORANGE
P	PINK
R	RED
V	VIOLET
W	WHITE
Y	YELLOW

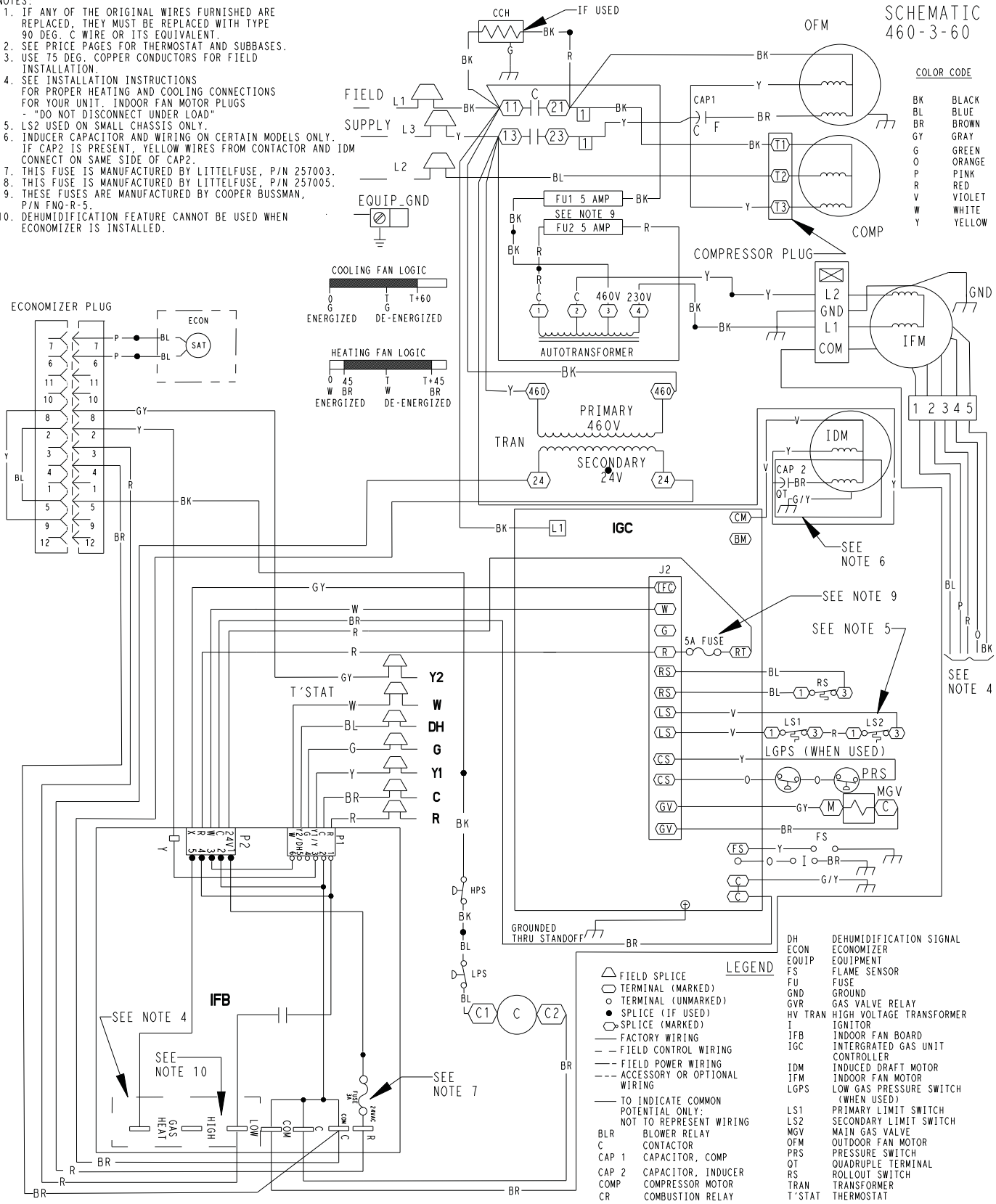

LADDER WIRING DIAGRAM

DANGER: ELECTRICAL SHOCK HAZARD DISCONNECT POWER BEFORE SERVICING

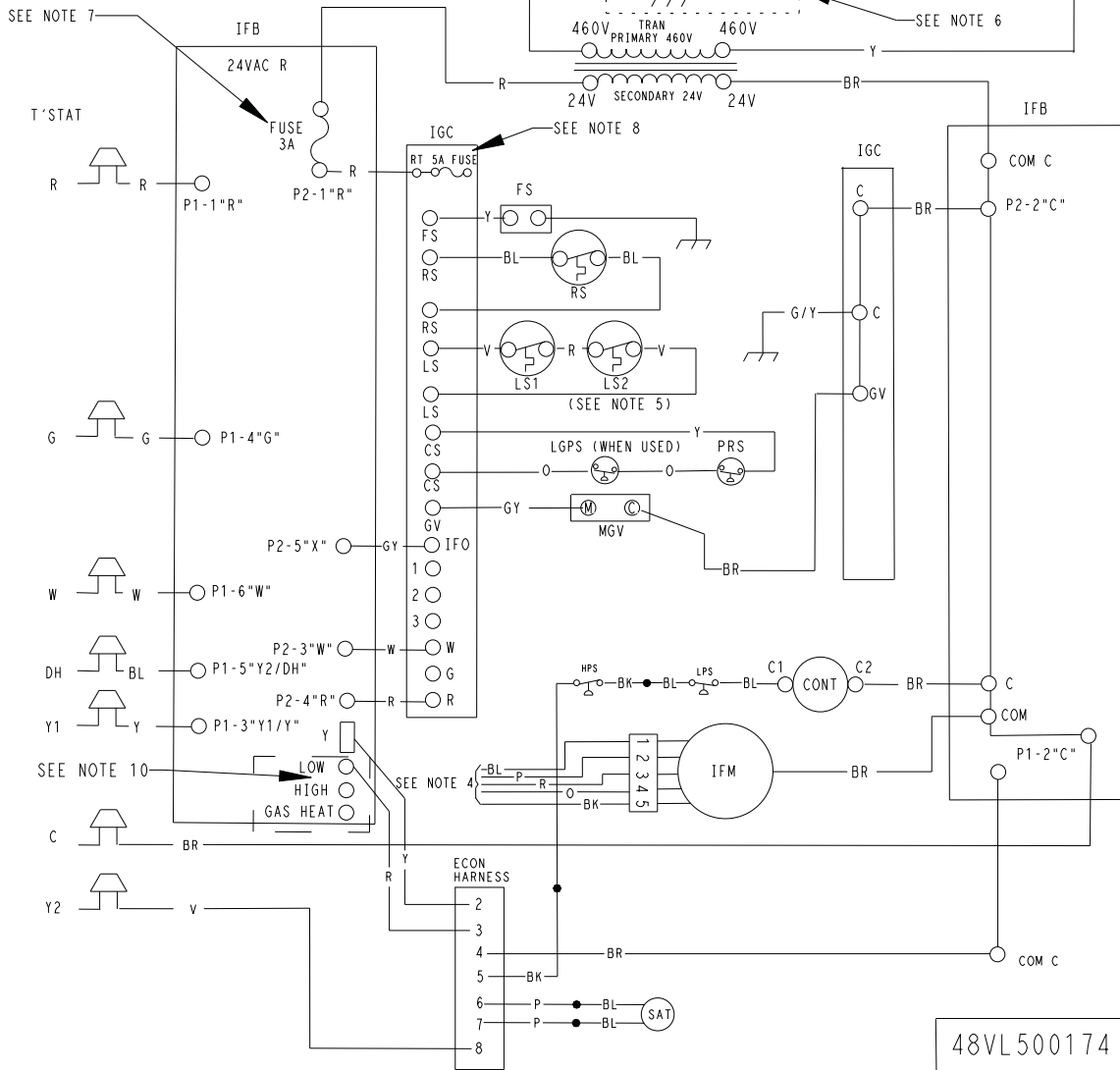
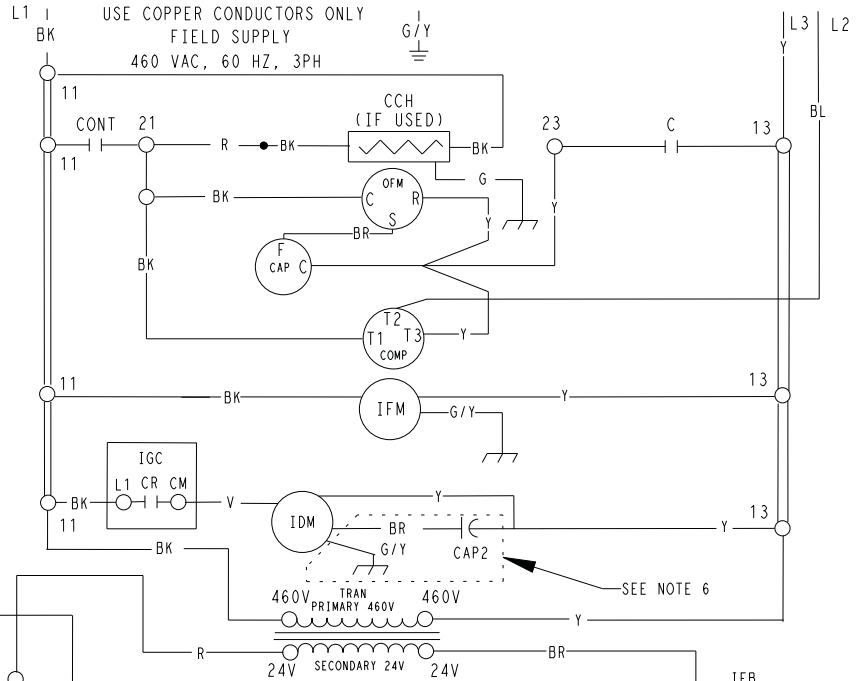
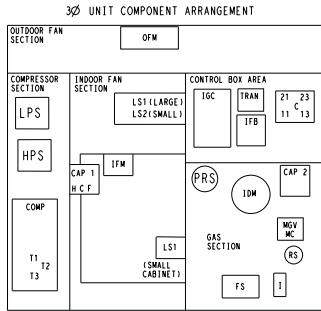

48VL500174 C

CONTROLS

Operating sequence

Heating (Single Phase Models) – (See unit wiring label) On a call for heating, terminal W of the thermostat is energized, starting the induced-draft motor for a 5 second pre-purge. When the pressure switch senses that the induced-draft motor is moving sufficient combustion air, the burner sequence begins. This function is controlled by the integrated gas unit controller (IGC). The indoor (evaporator) fan motor is energized 30 seconds after flame is established. When the thermostat is satisfied and W is de-energized, the burners stop firing and the indoor (evaporator) fan motor shuts off after a 90 second time-off delay. Please note that the IGC has the capability to automatically reduce the indoor fan motor on delay and increase the indoor fan motor off delay in the event of high duct static and/or a partially-clogged filter.

Heating (Three Phase Models) – On a call for heating, terminal W of the thermostat is energized, starting the induced-draft motor. When the pressure switch senses that the induced-draft motor is moving sufficient combustion air, the burner sequence begins. This function is performed by the integrated gas unit controller (IGC). The indoor (evaporator) fan motor is energized 45 sec after flame is established. When the thermostat is satisfied and W is de-energized, the burners stop firing and the indoor (evaporator) fan motor shuts off after a 45-sec time-off delay. Please note that the IGC has the capability to automatically reduce the indoor fan motor on delay and increase the indoor fan motor off delay in the event of high duct static and/or partially-clogged filter.

Cooling — When the system thermostat calls for cooling, 24 V is supplied to the “Y” and “G” terminals of the thermostat. This completes the circuit to the contactor coil (C) and indoor (evaporator) fan relay (IFR). The normally open contacts of energized C close and complete the circuit through compressor motor (COMP) to outdoor (condenser) fan motor (OFM). Both motors start instantly. The set of normally open contacts of energized IFR close and complete the circuit through IFM. The IFM starts instantly.

On the loss of the thermostat call for cooling, 24 V is removed from both the “Y” and “G” terminals (provided the fan switch is in the “AUTO” position) de-energizing the compressor contactor and opening the contacts supplying power to compressor/OFM. After a 60-second delay (1-phase) or 90-second delay (3-phase), the IFM shuts off. If the thermostat fan selector switch is in the “ON” position, the IFM will run continuously.

NOTE: On units with a Time Guard® II device: Once the compressor has started and then stopped, it cannot be restarted again until 5 minutes have elapsed.

GUIDE SPECIFICATIONS

Packaged Gas Heating/Electric Cooling Units Constant Volume Application

HVAC Guide Specifications

Size Range: **2 to 5 Tons, Nominal Cooling
40,000 to 127,000 Btuh,
Nominal Heating Input**

SYSTEM DESCRIPTION

Outdoor rooftop mounted, gas heating/electric cooling unit utilizing a hermetic scroll compressor for cooling duty. Unit shall discharge supply air vertically or horizontally as shown on contract drawings. Condenser fan/coil section shall have a draw-thru design with vertical discharge for minimum sound levels.

QUALITY ASSURANCE

A. Unit shall be rated in accordance with AHRI Standards 210/240 and 270-1995.

- B. Unit shall be designed in accordance with UL Standard 1995 and ANSI Z 21.47.
- C. Unit shall be manufactured in a facility registered to ISO 9001 manufacturing quality standard.
- D. Unit shall be UL listed and c-UL certified as a total package for safety requirements.
- E. Roof curb shall be designed to conform to NRCA Standards.
- F. Insulation and adhesives shall meet NFPA 90.1 requirements for flame spread and smoke generation.
- G. Cabinet insulation shall meet ASHRAE Standard 62.2.

DELIVERY, STORAGE AND HANDLING

Unit shall be stored and handled per manufacturer's recommendations.

Part 2 — Products

EQUIPMENT

A. General:

Factory-assembled, single-piece, heating and cooling unit. Contained within the enclosure shall be all factory wiring, piping, controls, refrigerant charge with R-410A refrigerant, and special features required prior to field start-up.

B. Unit Cabinet:

- 1. Unit cabinet shall be constructed of phosphated, zinc-coated, pre-painted steel capable of with-standing 500 hours in salt spray.
- 2. Normal service shall be through 3 removable cabinet panels.
- 3. The unit shall be constructed on a rust proof unit base that has an externally trapped, integrated sloped drain.
- 4. Evaporator fan compartment top surface shall be insulated with a minimum 1/2-in. (12.7 mm) thick, flexible fiberglass insulation, coated on the air side and retained by adhesive and mechanical means. The evaporator wall sections will be insulated with a minimum semi-rigid foil-faced board capable of being wiped clean. Aluminum foil-faced fiberglass insulation shall be used in the entire indoor air cavity section.
- 5. Unit shall have a field-supplied condensate trap.

C. Fans:

- 1. The evaporator fan shall be a multi-speed, direct-drive, as shown on equipment drawings.
- 2. Fan wheel shall be made from steel, be double-inlet type with forward curved blades with corrosion resistant finish. Fan wheel shall be dynamically balanced.
- 3. Condenser fan shall be direct drive propeller type with aluminum blades riveted to corrosion resistant steel spiders, be dynamically balanced, and discharge air vertically.

D. Compressor:

- 1. Fully hermetic compressors with factory-installed vibration isolation.
- 2. Scroll compressors shall be standard on all units.

E. Coils:

Evaporator and condenser coils shall have aluminum plate fins mechanically bonded to seamless copper tubes with all joints brazed. Tube sheet openings shall be belled to prevent tube wear.

F. Heating Section:

- 1. Induced-draft combustion type with energy saving direct spark ignition system and redundant main gas valve.
- 2. Induced-draft motors shall provide adequate airflow for combustion.
- 3. The heat exchangers shall be constructed of aluminized steel for corrosion resistance.

4. Burners shall be of the in-shot type constructed of aluminum coated steel.
 5. All gas piping and electric power shall enter the unit cabinet at a single location.
- G. Refrigerant Components:
Refrigerant expansion device shall be of the TXV (thermostatic expansion valve) type.
- H. Filters:
Filter section shall consist of field-installed, throwaway, 1-in. (25 mm) thick fiberglass filters of commercially available sizes.
- I. Controls and Safeties:
1. Unit controls shall be complete with a self-contained low voltage control circuit.
 2. Compressors shall incorporate a solid-state compressor protector that provides reset capability.
- J. Operating Characteristics:
1. Unit shall be capable of starting and running at 125°F (51°C) ambient outdoor temperature per maximum load criteria of AHRI Standard 210.
 2. Compressor with standard controls shall be capable of operation down to 40°F (4°C) ambient outdoor temperature.
 3. Units shall be provided with fan time delay to prevent cold air delivery before the heat exchanger warms up.
 4. Unit shall be provided with 60-second fan time delay (single phase models) or 90 second fan time delay (three phase models) after the thermostat is satisfied.
- K. Electrical Requirements:
All unit power wiring shall enter the unit cabinet at a single location.
- L. Motors:
1. Compressor motors shall be of the refrigerant-cooled type with line-break thermal and current overload protection.
 2. All fan motors shall have permanently lubricated bearings, and inherent, automatic reset, thermal overload protection.
 3. Condenser fan motor shall be totally enclosed.
 4. Evaporator Fan Motor to be ECM Motor.
- M. Compressor Protection:
Solid-state control shall protect compressor by preventing "short cycling."
- N. Low NOx:
Shall provide NOx reduction to values below 40 nanograms/joule to meet California's and other localities' emission requirements as shipped from factory.
- O. Special Features Available:
1. Coil Options
Base unit with tin plated indoor coil hairpins available as a factory installed option.
 2. Compressor Start Kit (single phase units only):
Shall provide additional starting torque for single-phase compressors.
 3. Thermostat:
To provide for one-stage heating and cooling in addition manual or automatic changeover and indoor fan control.
4. Crankcase Heater:
Shall provide anti-floodback protection for low-load cooling applications.
 5. Economizer:
(Horizontal – Field installed accessory)
(Vertical – Field installed accessory or factory installed option)
 - a. Economizer controls capable of providing free cooling using outside air.
 - b. Equipped with low leakage dampers not to exceed 3% leakage, at 1.0 IN. W.C. pressure differential.
 - c. Spring return motor shuts off outdoor damper on power failure.
 6. Filter Rack Kit:
Shall provide filter mounting for downflow applications. Offered as an accessory or as a factory installed option.
 7. Flat Roof Curb:
Curbs shall have seal strip and a wood nailer for flashing and shall be installed per manufacturer's instructions.
 8. Flue Discharge Deflector
Directs flue gas exhaust; 90 degrees upward from current discharge.
 9. Heat Exchanger
Stainless Steel Heat Exchanger available as a factory installed option.
 10. High Altitude Propane Conversion Kit:
Shall consist of all required hardware to convert to propane gas heat operation at 2001 to 6000 ft (611 to 1829 m) above sea level.
 11. Low Ambient Package:
Shall consist of a solid-state control and condenser coil temperature sensor for controlling condenser-fan motor operation, which shall allow unit to operate down to 0°F (-18°C) outdoor ambient temperature when properly installed.
 12. Manual Outdoor Air Damper:
Package shall consist of damper, birdscreen, and rainhood which can be preset to admit outdoor air for year-round ventilation.
 13. Natural-to-Propane Conversion Kit:
Shall be complete with all required hardware to convert to propane gas operation at 10.0 IN. W.C. manifold pressure.
 14. Propane-to-Natural Conversion Kit
Shall be complete with all hardware to convert to natural gas at standard altitude (0 to 2000 ft [0 to 610 m] above sea level).
 15. Square-To-Round Duct Transitions (24-48 models):
Shall have the ability to convert the supply and return openings from rectangular to round.
 16. Time Guard II
Automatically prevents the compressor from restarting for at least 4 minutes and 45 seconds after shutdown of the compressor. Not required when a corporate programmable thermostat is applied or with a RTU-MP control.

PGD4, PGS4 ACCESSORIES

Accessory Model Number	Description	Use With
CURBS		
CPRFCURB010A00	Roof Curb, 11" High	24 – 60
CPRFCURB011A00	Roof Curb, 14" High	24 – 60
CPRFCURB012A00	Roof Curb, 11" High	42 – 60
CPRFCURB013A00	Roof Curb, 14" High	42 – 60
Note: CPRFCURB010A00 AND CPRFCURB011A00 can be used with 42–60 size units with some overhang.		
ADAPTER CURBS*		
CPADCURB001A00	Adapter curb for use with NPRFCURB006A00 & NPRFCURB007A00	24 – 36
CPADCURB002A00	Adapter curb for use with NPRFCURB008A00 & NPRFCURB009A00	42 – 60
* Can also be used when replacing other manufacturer's older generation units that contain a composite base without a metal base rail.		
CONCENTRIC ADAPTERS – (Use with curb only)		
NPCONADP001A00	For 18" round duct (use with curbs CPRFCURB010A00, CPRFCURB011A00)	Small Curb
NPCONADP002A00	For 18" round duct (use with curbs CPRFCURB012A00, CPRFCURB013A00)	Large Curb
ECONOMIZERS		
CPECOMZR007A00	Dedicated Vertical Economizer – Internal with solid state controller, gear driven, fully modulating damper, spring return actuator, up to 50% barometric relief, supply and dry bulb outdoor air sensors. Includes filter rack with 1" filters*.	24 – 36
CPECOMZR008A00		42 – 48
CPECOMZR009A00		60
CPECOMZR010A00	Dedicated Horizontal Economizer – Internal with solid state controller, fully modulating damper, spring return actuator, supply and dry bulb outdoor air sensor, and low ambient compressor lockout switch included. Includes filter rack with 1–inch filters*.	24 – 36
CPECOMZR011A00		42 – 48
CPECOMZR012A00		60
AXB078ENT	Outdoor Enthalpy Control	ALL
* Outdoor enthalpy available as field installed accessory; Filter rack and 1" filter, same as CPFILTRK kit		
DAMPERS		
CPMANDPR007A00	Manual Outside Air Damper (Includes filter rack and 1" filter, same as CPFILTRK kit)	30 – 36
CPMANDPR008A00		42 – 48
CPMANDPR009A00		60
INTERNAL FILTER RACKS		
CPFILTRK007A00	Internal Filter Rack (includes 1–inch filters)	30 – 36
CPFILTRK008A00		42– 48
CPFILTRK009A00		60
CRANKCASE HEATER – BELLY BAND TYPE		
NPCRKHTR008A00	240V Crankcase Heater (3–phase)	24 – 36
NPCRKHTR004A00	240V Crankcase Heater (42 & 48 3–phase, 60 single phase)	42 – 60
NPCRKHTR009A00	460V Crankcase Heater	36
NPCRKHTR005A00	460V Crankcase Heater	42 – 48
LOW AMBIENT, ANTI-CYCLE TIMER, COMPRESSOR START ASSIST		
CPLOWAMB001A00	Low Ambient Control – enables cooling system to operate down to 0 Deg. F by cycling condenser fan on and off.	ALL
NRTIMEGD001A00	Five Minute Compressor Delay	ALL
CPHSTART002A00	PTC Compressor Start Assist Kit	ALL
HAIL GUARDS / COIL PROTECTION (Factory installed on PGS models)		
NAPA00501GR	3/8" spacing dense wire grilles	24
NAPA00701GR	3/8" spacing dense wire grilles	30
NAPA00901GR	3/8" spacing dense wire grilles	36
NAPA00601GR	3/8" spacing dense wire grilles	42
NAPA01001GR	3/8" spacing dense wire grilles	48
NAPA01201GR	3/8" spacing dense wire grilles	60
GAS CONVERSION KITS		
NPLPCONV013C00	Natural to LP Conversion Kit (0 – 2000')	ALL
NPLPCONV014C00	Natural to LP Conversion Kit (2001' – 6000')	ALL
NPNGCONV004C00	LP to Natural Gas Conversion Kit (0 – 2000')	ALL
FLUE DISCHARGE DEFLECTOR		
CPFLUEDS001A00	Directs flue gas exhaust 90 degrees upward from current discharge. Designed to allow tighter distances between unit and combustible surfaces. 24 inch Height. AGA certified.	ALL
DUCT TRANSITIONS		
NPDUCFLG002A00	Square to Round (1 set of 2, use with horizontal duct flanges only)	30–48