

THE PLATINUM LINE

SETTING THE STANDARD FOR PREMIUM CHAIN FITTINGS

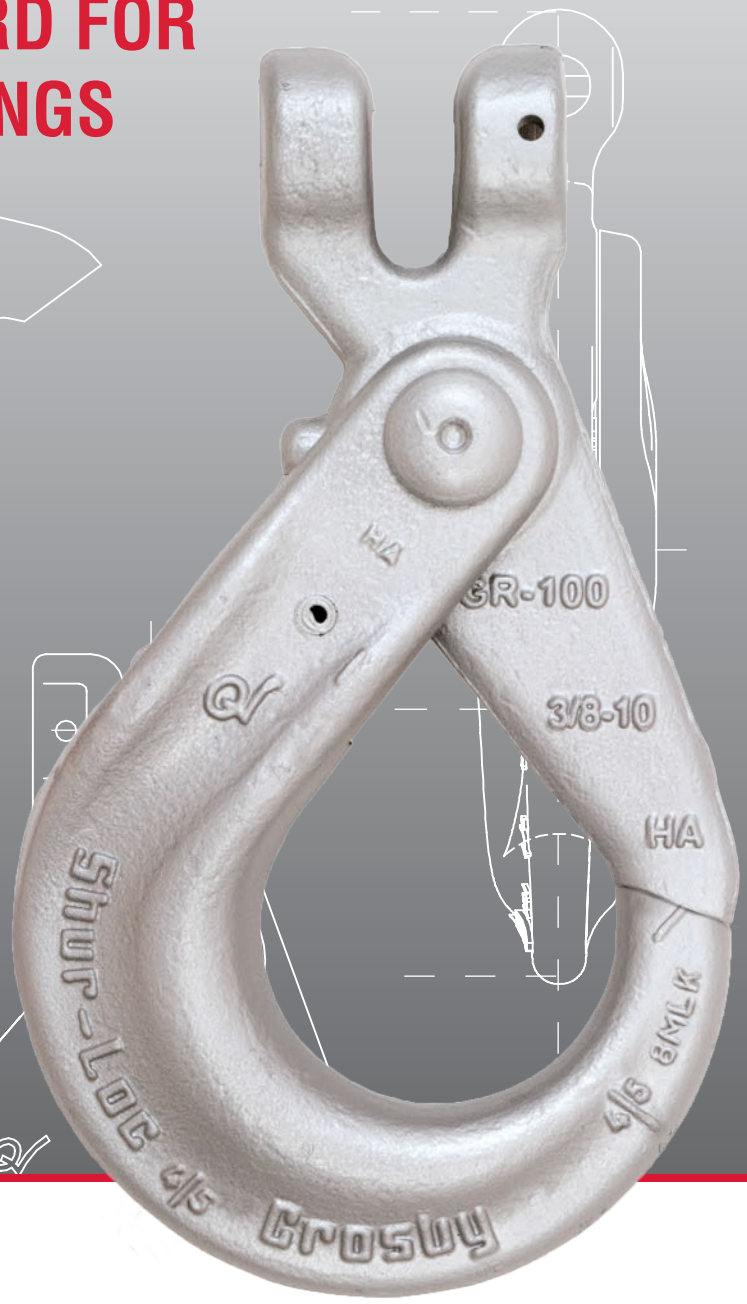
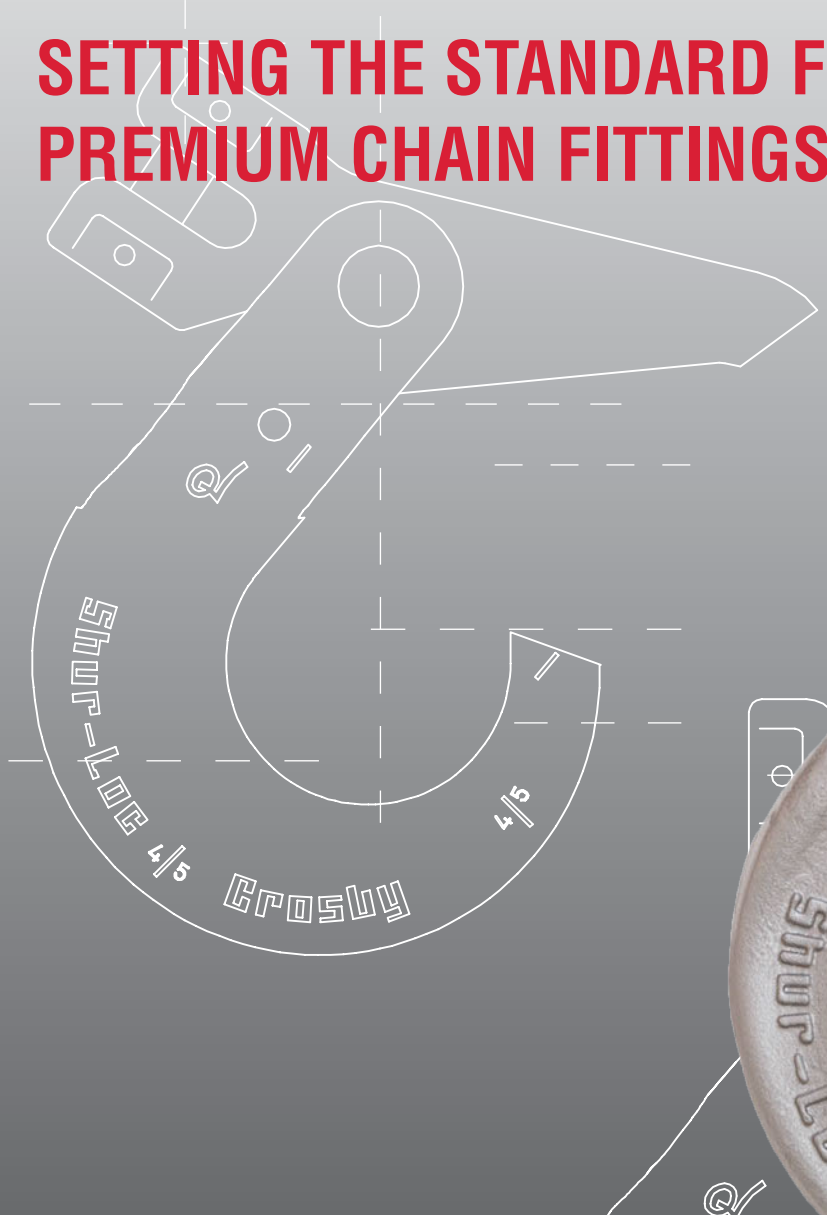

METRIC

Featuring:

Crosby 8/10™

CROSBY SPECTRUM 10®
GRADE 100 CHAIN FITTINGS



Scan this QR Code with your smart device to view this brochure electronically.

Crosby® 8/10 Chain Fittings

Table of Contents

Crosby Grade 8/10 Chain System – “The Platinum Line”	1
Crosby Grade 8/10 Chain System – The QUIC-CHECK® System	2
Crosby Hooks	3
Crosby ELIMINATOR® System.....	4-5
RFID Information	6-7
Chain Sling Components.....	8
Crosby Grade 100 Chain Sling Components.....	9
Grade 100 Alloy Chain.....	10
Welded Master Links	11
Crosby ELIMINATOR® Fittings.....	12
Crosby Grade 100 Chain Fittings.....	13
Crosby Grade 100 Grab Hooks	14
Crosby Grade 100 SHUR-LOC® Hooks.....	15
Crosby Grade 100 SHUR-LOC® Swivel Hooks.....	16
Crosby Grade 100 Sling & Foundry Hooks.....	17
Crosby Grade 100 Choker Hook & Reeving Link.....	18
Sling Identification Tag Kits.....	19
Replacement Kits	20
Grade 80 Alloy Chain.....	21
Grade 80 Assembly Chart	22
Welded Master Links	23
Alloy Fittings Application and Information	24
Warning and Application Information.....	25-27
Crosby Mobile Apps.....	28

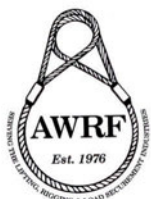

Crosby®



Scan this QR Code with your smart device to visit our website.

Crosby Europe:

BELGIUM

Industriepark Zone b N°26
2220 Heist-op-den-Berg

P: (+32) (0)15 75 71 25
F: (+32) (0)15 75 37 64
sales@crosbyeurope.com

FRANCE

21, rue du Petit Albi
Parc d'Affaires Silic
95800 Cergy - St. Christophe
P: (+33) (0)1 34 201 180
F: (+33) (0)1 34 201 188
sales@crosbyeurope.fr

UNITED KINGDOM

Station Street
Cradley Heath
West Midlands B64 6AJ
P: (+44) (0)1226 290 516
F: (+44) (0)1226 240 118
sales@crosbyeurope.co.uk

www.thecrosbygroup.com

The Market Leader Yesterday, Today and Tomorrow

Crosby® Grade 8/10 Chain System

Platinum Line – “Setting the Standard for Premium Chain Fittings”

What does **Crosby 8/10™** mean for you?

It means you have a line of premium chain hardware that ...

- ... is 20% to 25% stronger (size for size) than available Grade 80 fittings.
- ... can be used with either Grade 100 or Grade 80 EN818 chain.
- ... in addition to meeting the requirements of the Grade 100 specification, meets the performance, dimensional and functionality requirements of Grade 80 specification EN818 and EN1677.
- ... includes all the performance properties you have come to expect from Crosby Grade 80 fittings as well as other Crosby products.
 - Working Load Limit (meets industry standards)
 - Ductility (allows product to deform when overloaded)
 - Toughness (resistance to crack initiation and growth at all temperatures)
 - Fatigue (ability to withstand repeated applications of the load)

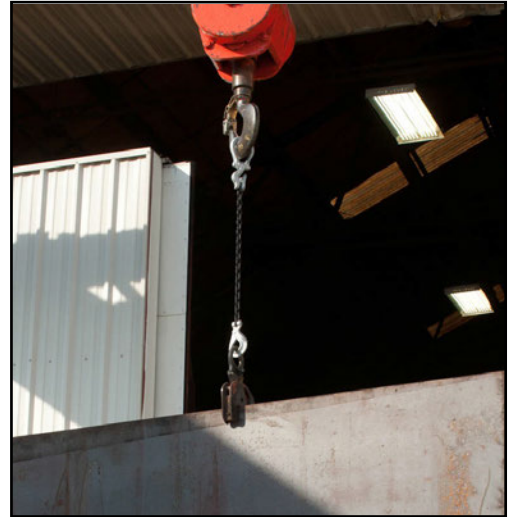

Crosby Grade 100 products achieve the above properties due to careful design. Simply changing the heat treat process to increase the Working Load Limit has the potential of sacrificing the other three properties. For Crosby, that was not an option!

Additional Features



Fatigue Rated®

QUIC-CHECK®



- ✓ Forged Alloy Steel – Quenched and Tempered.
- ✓ Fatigue Rated at 1-1/2 times the Working Load Limit at 20,000 cycles.
- ✓ Individually Proof Tested with Certification.
 - Master links are individually proof tested to values shown for respective product.
 - All other fittings are individually proof tested to 2-1/2 times the Working Load Limit.
- ✓ Hoist Hooks incorporate markings forged into the product which address two (2) **QUIC-CHECK®** features – Deformation Indicators and Angle Indicators. (See page 2 for details.)

“Ask for the Platinum Line.”

Crosby® Grade 8/10 Chain System

Crosby Hoist hooks incorporate markings forged into the product which address two (2) **QUIC-CHECK®** features.

QUIC-CHECK®

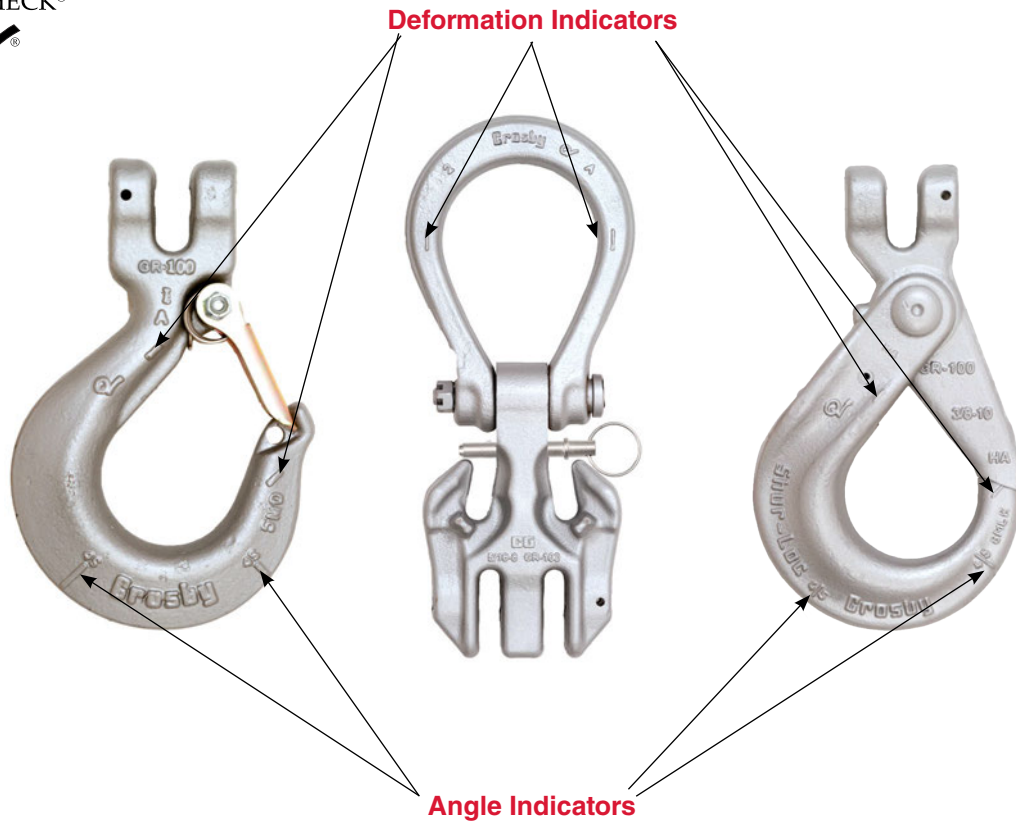

- **Deformation Indicators** – Two strategically placed marks, one just below the eye and the other on the hook tip, which allows for a **QUIC-CHECK® measurement** to determine if the throat opening has changed, thus indicating abuse or overload. To check, use a measuring device (i.e. tape measure) to measure the distance between the marks. The marks should align to either an inch or half-inch increment on the measuring device. If the measurement does not meet this criteria, the hook should be inspected further for possible damage.
- **Angle Indicators** – Indicates the maximum included angle which is allowed between two (2) sling legs in the hook. These indicators also provide the opportunity to approximate other included angles between two sling legs.

Crosby QUIC-CHECK® Reference Chart for Grade 8/10 Hooks

Crosby Catalog No.	L-1361	L-1362	S-1317	S-1316	S-1326	S-13326	L-1339	L-1327	A-1359	A-1329
Brochure Page No.	12	12	15	15	16	16	17	17	17	17
QUIC-CHECK® Deformation Indicators	✓	✓	✓	✓	✓	✓	✓	✓	✓	✓
QUIC-CHECK® Angle Indicators	✓	✓	✓	✓	✓	✓	✓	✓		

Crosby® Grade 8/10 Chain Hooks

Crosby® Grade 8/10 hooks provide many features, making them perfect for your rigging needs.

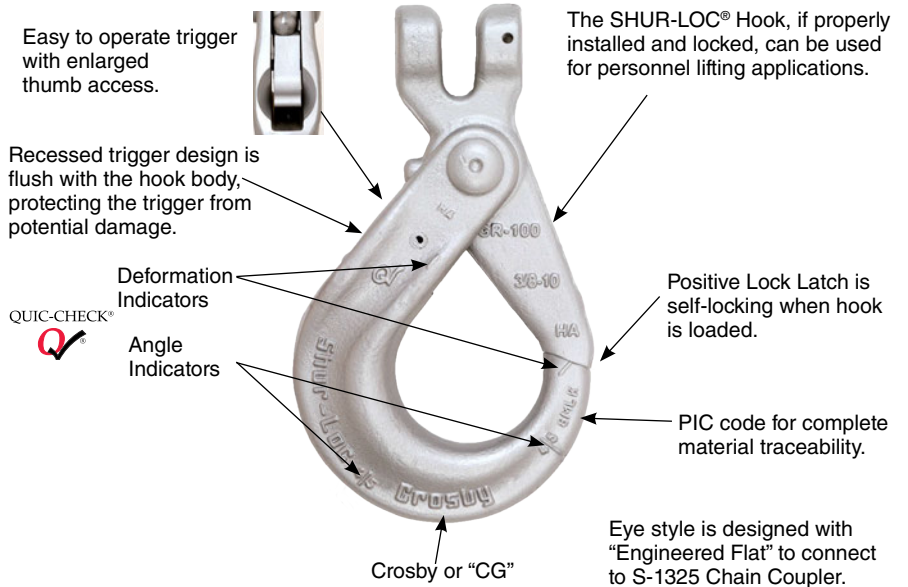

- Innovative cradle design allows for 100% efficiency of Grade 100 chain.
- The use of A-1338 Cradle Grab Hook will allow 100% of the chain sling capacity. When used to hook back to chain leg to form a choker, the angle of the choke must be 120 degrees or greater.

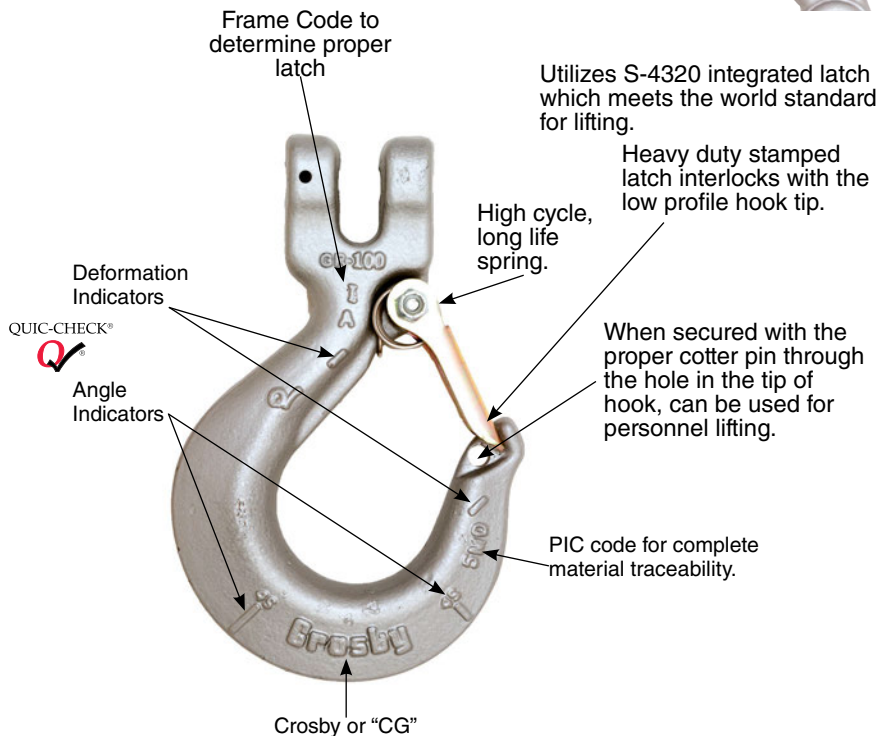

**“Look for the Platinum Line”
“Setting the Standard for
Premium Chain Fittings”**

Crosby ELIMINATOR®

Innovative Design

The Crosby **ELIMINATOR**® is the result of extensive designing and testing by Crosby's engineering department. Utilizing the capabilities of our state-of-the-art ProENGINEER® software, our engineers were able to model and perform stress analysis of anticipated loading conditions to optimize the product design.

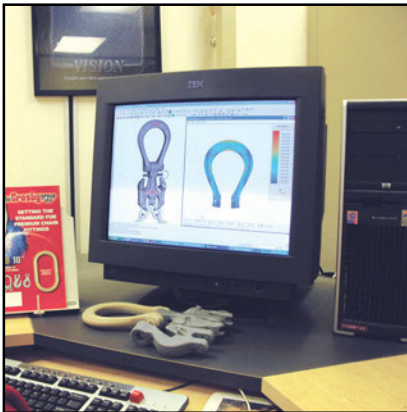

- Chain shorteners are “built-in,” eliminating the need for additional legs of chain and components.
- Chain shortener pockets are designed to provide 100% efficiency of chain strength when adjusting the sling's length.
- Traditional adjustable slings must be de-rated 20%; this isn't necessary with the Crosby **ELIMINATOR**®.
- The Crosby **ELIMINATOR**® is a two-piece system for maximum flexibility and compatibility.
- Equipped with Crosby RFID technology for enhanced inspection processing.



Adjusted L-1361
Crosby **ELIMINATOR**®



Adjusted L-1362
Crosby **ELIMINATOR**®

The Crosby **ELIMINATOR**® can be used “as-is,” or your authorized Crosby distributor can assemble it onto a larger master link to accommodate larger crane hooks.



Crosby **ELIMINATOR**® attached to A-1343 master link for use with multiple leg slings or for use with large hooks

Engineered to accommodate optional latch pin that can be inserted to keep the shortened chain legs in place under slack conditions.



Platinum color quickly identifies the Crosby **ELIMINATOR**® as a Spectrum 10 component with Grade 100 Working Load Limits.



Crosby ELIMINATOR®

Fewer Components

As the name implies, the primary advantage of the Crosby **ELIMINATOR**® system over traditional adjustable length chain slings is that it has eliminated many of the required fittings, thus reducing the complexity of the sling. The following photos and table provide you the potential reduction of fittings you can expect.



Traditional chain sling rigging



Crosby **ELIMINATOR**® rigging

Potential Chain Fitting Reduction Table			
Number of Legs	Adjustable Sling Type		% Reduction
	Traditional	Crosby ELIMINATOR ®	
1	5	2	60%
2	9	3	67%
3	13	6	54%
4	17	7	59%

Lighter Weight

By eliminating chain and components, the weight of the Crosby **ELIMINATOR**® system has been reduced by up to 15% when compared to traditional chain slings.

- A traditional 10 mm x 3 m AQOS (four leg sling with chain shortener) weighs 11.6 kg (less chain). A Crosby **ELIMINATOR**® quad leg sling with master link and sling hooks (EQOS) 10 mm x 3 m weighs 10 kg, 14% lighter than the “traditional” method.
- This weight difference becomes even more pronounced if comparing a Crosby **ELIMINATOR**® sling with a traditional Grade 80 adjustable sling.

Easier To Inspect

With far fewer components, slings fabricated utilizing the Crosby **ELIMINATOR**® system can be more easily inspected for potential “removal from service” conditions specified in EN 1677.

- Less crowding of the master link makes it easier to examine all surfaces of all components for signs of wear.
- Fewer components allow a Crosby **ELIMINATOR**® sling to be inspected faster than traditional adjustable slings.



Contains Patented Crosby QUIC-CHECK® Markings

The L-1361 (Single leg) and the L-1362 (Double leg) Crosby **ELIMINATOR**® fittings incorporate markings forged into the bail which address the following Crosby **QUIC-CHECK**® feature:

Deformation Indicators – Two strategically placed marks, one on each side of the bail, which allow for a **QUIC-CHECK**® measurement to determine if the bail dimensions have changed, thus indicating abuse or overload.

To check, use a measuring device (i.e., tape measure) to measure the distance between the marks. The marks should align to either an inch or half-inch increment on the measuring device. If the measurement does not meet this criteria, the Crosby **ELIMINATOR**® should be inspected further for possible damage.

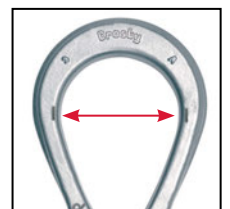

Another Industry First

The New Crosby QUIC-CHECK[®] Inspection and Identification System

The Process is Simple, Efficient and Accurate

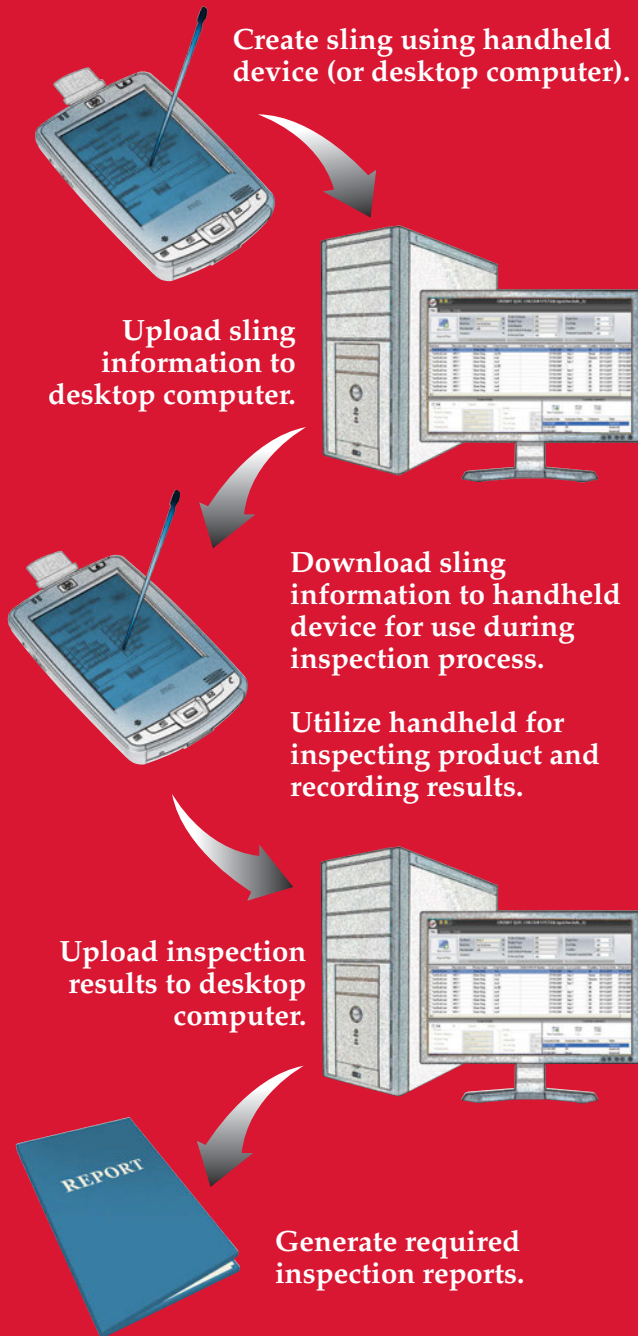

The Crosby QUIC-CHECK[®] Inspection and Identification System assists in making inspections more efficient, more accurate and more timely.

The Crosby QUIC-CHECK[®] Inspection and Identification System has been designed to provide a more accurate and efficient system for



inspecting slings and various Crosby products. This is accomplished by combining an electronic inspection software program developed by Crosby with RFID (Radio Frequency Identification) technology. The Crosby QUIC-CHECK[®] Inspection and Identification System also provides the user a quick reference to valuable inspection information on the specific product being inspected.

U.S. Patent # 7,825,770

Crosby QUIC-CHECK[®] Inspection and Identification System.

Every sling to be inspected. It also requires the user to have a written inspection report on file for the most recent inspection. Using conventional inspection methods, the complete process (from inspection to the final printed report) can be very labor intensive and time consuming, and time is money. Using a series of drop down menus and check boxes, the inspector easily records the condition of the product in accordance with the EN Standards.



In addition to providing you a competitive advantage, the Crosby QUIC-CHECK[®] Inspection and Identification System provides the following two major advantages over conventional inspection methods:

- The system provides a more streamlined approach to inspection, while reducing the total time associated with the current process.
- It allows for a reduction in the manpower required when performing the inspection, while also providing quicker inspection reports with a higher level of accuracy.

Utilizing innovation to provide a streamlined and automated approach to the inspection process.

Inspection information in the palm of your hand.



The QUIC-CHECK® Tag Reader option of the Pocket QUIC-CHECK® system (located on the portable handheld device), allows the user quick reference to the status of any sling or product fitted with Crosby's RFID identification system. By simply

scanning the appropriate tag, the user can quickly determine the following information about the sling or product:

- QUIC-CHECK® ID number
- Product Type (.i.e., Chain Sling, Wire Rope Sling, Synthetic Sling, Shackle, etc.)
- In Service Date
- Date of Last Recorded Inspection
- Status of product at Last Recorded Inspection



Benefits of System

- Reduces total inspection process time up to 65%.
- Reduces cost of overall inspection process.
- Enhanced data accuracy – Eliminates errors inherent in current process.
 - No more handwritten inspection reports.
 - No more manual typing of inspection reports.
- Provide inspection reports quicker, with a higher level of accuracy.
- Ability to keep electronic records of slings produced/inspected.
- Ability to quickly reference support materials designed to facilitate the inspection process.
- Maintains an electronic file of each sling and various Crosby hardware supplied to an end user – From sling inception thru last inspection.

RFID-Equipped Crosby® Products











Many standard Crosby® products come from the factory equipped with RFID chips that you can program and utilize in your inspection efforts.



“The Mark of Value Added Intelligent Lifting Hardware”

Grade 100 Assembly Chart

SINGLE LEG SLING

										
Spectrum 10 [®] Chain Size (mm)	Grade 100 Chain Stock No.	Master Link A-1343 Stock No.	Master Link Assembly A-1346 Stock No.	ELIMINATOR [®] L-1361 Stock No.	LOK-A-LOY [®] A-1337 Stock No.	Chain Coupler S-1325A Stock No.	Chain Shortener Link S-1311N Stock No.	SHUR-LOC [®] Clevis Hook S-1317 Stock No.	SHUR-LOC [®] Eye Hook S-1316 Stock No.	SHUR-LOC [®] Swivel Hook S-1326 Stock No.
7	1210055	1247076	—	1049802	1015104	1098500	1017869	1029000	1022914	1004313
8	1210076	1247076	—	1049809	1015113	1098504	1017878	1029009	1022914	1004313
10	1210097	1247087	—	1049818	1015122	1098508	1017897	1029018	1022923	1004322
13	1210118	1247096	—	1049827	1015136	1098512	1017906	1029027	1022932	1004331
16	1210139	1247124	—	1049836	1015145	1098516	1017915	1029036	1022941	1004340
18	1210160	1247133	—	—	1015154	—	—	1029071	1022942	1004349
20	1210160	1247142	—	—	1015154	—	—	1021071	1022942	1004349
22-23	1210202	1247151	—	—	1015163	—	—	1029080	1022943	1004358
26	1210223	1247160	—	—	1015172	—	—	1029089	1022944	—
32	—	1247165	—	—	1015181	—	—	—	—	—

DOUBLE LEG SLING

Spectrum 10 [®] Chain Size (mm)	Grade 100 Chain Stock No.	Master Link A-1343 Stock No.	Master Link Assembly A-1346 Stock No.	ELIMINATOR [®] L-1362 Stock No.	LOK-A-LOY [®] A-1337 Stock No.	Chain Coupler S-1325A Stock No.	Chain Shortener Link S-1311N Stock No.	SHUR-LOC [®] Clevis Hook S-1317 Stock No.	SHUR-LOC [®] Eye Hook S-1316 Stock No.	SHUR-LOC [®] Swivel Hook S-1326 Stock No.
7	1210055	1247087	—	1049913	1015104	1098500	1017869	1029000	1022914	1004313
8	1210076	1247087	—	1049922	1015113	1098504	1017878	1029009	1022914	1004313
10	1210097	1247096	—	1049931	1015122	1098508	1017897	1029018	1022923	1004322
13	1210118	1247124	—	1049940	1015136	1098512	1017906	1029027	1022932	1004331
16	1210139	1247142	—	1049949	1015145	1098516	1017915	1029036	1022941	1004340
18	1210160	1247151	—	—	1015154	—	—	1029071	1022942	1004349
20	1210160	1247151	—	—	1015154	—	—	1021071	1022942	1004349
22-23	1210202	1247160	—	—	1015163	—	—	1029080	1022943	1004358
26	1210223	1247165	—	—	1015172	—	—	1029089	1022944	—
32	—	1247172	—	—	1015181	—	—	—	—	—











TRIPLE AND QUAD LEG SLINGS

Spectrum 10 [®] Chain Size (mm)	Grade 100 Chain Stock No.	Master Link A-1343 Stock No.	Master Link Assembly A-1346 Stock No.	ELIMINATOR [®] Stock No.	LOK-A-LOY [®] A-1337 Stock No.	Chain Coupler S-1325A Stock No.	Chain Shortener Link S-1311N Stock No.	SHUR-LOC [®] Clevis Hook S-1317 Stock No.	SHUR-LOC [®] Eye Hook S-1316 Stock No.	SHUR-LOC [®] Swivel Hook S-1326 Stock No.
7	1210055	—	1256874	See Page 12	1015104	1098500	1017869	1029000	1022914	1004313
8	1210076	—	1256883		1015113	1098504	1017878	1029009	1022914	1004313
10	1210097	—	1256892		1015122	1098508	1017897	1029018	1022923	1004322
13	1210118	—	1256926		1015136	1098512	1017906	1029027	1022932	1004331
16	1210139	—	1256935		1015145	1098516	1017915	1029036	1022941	1004340
18	1210160	—	1256944		1015154	—	—	1029071	1022942	1004349
20	1210160	—	1256953		1015154	—	—	1021071	1022942	1004349
22-23	1210202	—	1256962		1015163	—	—	1029080	1022943	1004358
26	1210223	—	1256971		1015172	—	—	1029089	1022944	—
32	—	—	1014864*		1015181	—	—	—	—	—

* A-1345

Grade 100 Assembly Chart

SINGLE LEG SLING

										
Spectrum 10® Chain Size (mm)	SHUR-LOC® Swivel Hook w/ Bearing S-13326 Stock No.	Clevis Sling Hook L-1339 Stock No.	Eye Sling Hook L-1327 Stock No.	Cradle Grab Hook A-1338* Stock No.	Clevis Grab Hook A-1358* Stock No.	Cradle Grab Hook A-1348 Stock No.	Eye Grab Hook A-1328 Stock No.	Clevis Foundry Hook A-1359 Stock No.	Eye Foundry Hook A-1329 Stock No.	Chain Choker A-1355 Stock No.
7	1004413	1049112	1025869	1049417	1049610	1026200	1026169	1049907	1026280	1015204
8	1004413	1049121	1025869	1049426	1049629	1026200	1026169	1049911	1026280	1015204
10	1004422	1049130	1025878	1049435	1049638	1026209	1026187	1049916	1026289	1015213
13	1004431	1049149	1025887	1049444	1049647	1026218	1026196	1049925	1026297	1015222
16	1004440	1049158	1025896	1049453	1049656	1026227	1026205	1049934	1026306	1015231
18	—	1049167	1025915	—	—	—	1026214	1049943	1026315	—
20	—	1049167	1025915	—	—	—	1026214	1049943	1026315	—
22-23	—	1049176	1025924	—	—	—	1026223	1049952	1026324	—
26	—	—	1025933	—	—	—	1016232	—	—	—
32	—	—	1025942	—	—	—	1026241	—	—	—

DOUBLE LEG SLING

Spectrum 10® Chain Size (mm)	SHUR-LOC® Swivel Hook w/ Bearing S-13326 Stock No.	Clevis Sling Hook L-1339 Stock No.	Eye Sling Hook L-1327 Stock No.	Cradle Grab Hook A-1338* Stock No.	Clevis Grab Hook A-1358* Stock No.	Cradle Grab Hook A-1348 Stock No.	Eye Grab Hook A-1328 Stock No.	Clevis Foundry Hook A-1359 Stock No.	Eye Foundry Hook A-1329 Stock No.	Chain Choker A-1355 Stock No.
7	1004413	1049112	1025869	1049417	1049610	1026200	1026169	1049907	1026280	1015204
8	1004413	1049121	1025869	1049426	1049629	1026200	1026169	1049911	1026280	1015204
10	1004422	1049130	1025878	1049435	1049638	1026209	1026187	1049916	1026289	1015213
13	1004431	1049149	1025887	1049444	1049647	1026218	1026196	1049925	1026297	1015222
16	1004440	1049158	1025896	1049453	1049656	1026227	1026205	1049934	1026306	1015231
18	—	1049167	1025915	—	—	—	1026214	1049943	1026315	—
20	—	1049167	1025915	—	—	—	1026214	1049943	1026315	—
22-23	—	1049176	1025924	—	—	—	1026223	1049952	1026324	—
26	—	—	1025933	—	—	—	1016232	—	—	—
32	—	—	1025942	—	—	—	1026241	—	—	—

TRIPLE AND QUAD LEG SLINGS

Spectrum 10® Chain Size (mm)	SHUR-LOC® Swivel Hook w/ Bearing S-13326 Stock No.	Clevis Sling Hook L-1339 Stock No.	Eye Sling Hook L-1327 Stock No.	Cradle Grab Hook A-1338* Stock No.	Clevis Grab Hook A-1358* Stock No.	Cradle Grab Hook A-1348 Stock No.	Eye Grab Hook A-1328 Stock No.	Clevis Foundry Hook A-1359 Stock No.	Eye Foundry Hook A-1329 Stock No.	Chain Choker A-1355 Stock No.
7	1004413	1049112	1025869	1049417	1049610	1026200	1026169	1049907	1026280	1015204
8	1004413	1049121	1025869	1049426	1049629	1026200	1026169	1049911	1026280	1015204
10	1004422	1049130	1025878	1049435	1049638	1026209	1026187	1049916	1026289	1015213
13	1004431	1049149	1025887	1049444	1049647	1026218	1026196	1049925	1026297	1015222
16	1004440	1049158	1025896	1049453	1049656	1026227	1026205	1049934	1026306	1015231
18	—	1049167	1025915	—	—	—	1026214	1049943	1026315	—
20	—	1049167	1025915	—	—	—	1026214	1049943	1026315	—
22-23	—	1049176	1025924	—	—	—	1026223	1049952	1026324	—
26	—	—	1025933	—	—	—	1016232	—	—	—
32	—	—	1025942	—	—	—	1026241	—	—	—

* Available with latch attached.

Crosby® Grade 100 Alloy Chain & Fittings

Grade 100 Working Load Limit – 4 To 1 Design Factor

Nominal Size of Sling (mm)	Single Leg (t)	Two Leg Slings		Triple and Four-Leg Slings		Choker Hitch (t)*
		0°<β≤45° (t)	45°<β≤60° (t)	0°<β≤45° (t)	45°<β≤60° (t)	
6	1,40	2,00	1,40	3,00	2,12	2,24
7	2,00	2,80	2,00	4,20	3,00	3,20
8	2,50	3,55	2,50	5,30	3,75	4,00
10	4,00	5,60	4,00	8,00	6,00	6,40
13	6,70	9,50	6,70	14,0	10,0	10,70
16	10,0	14,0	10,0	21,2	15,0	16,00
19	14,0	20,0	14,0	30,0	21,0	22,40
22	18,8	27,0	18,8	39,4	28,0	30,10
23	21,0	29,5	21,0	44,4	31,5	33,50
26	27,0	38,0	27,0	57,0	40,0	43,00
32	40,0	56,0	40,0	85,0	60,0	64,00

* For choker applications, the Working Load Limit must be reduced by 20%. The Crosby A-1338 cradle grab hook does not require any reduction of the Working Load Limit. The design factor of 4 to 1 on Spectrum®10 Alloy Chain agrees with the design factor used by the International Standards Organization (I.S.O.) and is the preferred set of Working Load Limit values to be used.

Grade 100 Alloy Chain Recommended for Overhead Lifting Applications

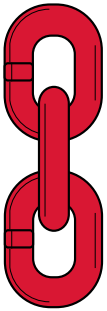

Chain Size (mm)	Gr. 100 Stock No.	Meters Per Drum	Dimensions (mm)	Working Load Limit (t)*	Weight Per Meter (kg)
7	1210055	200	7 x 21	2.0	1.05
8	1210076	200	8 x 24	2.5	1.25
10	1210097	200	10 x 30	4.0	2.20
13	1210118	150	13 x 39	6.7	3.80
16	1210139	100	16 x 48	10.0	5.70
19	1210160	50	19 x 57	14.0	8.03
23	1210202	50	23 x 69	21.0	10.9
26	1210232	50	26 x 78	27.0	15.2
32	1210250	20	32 x 96	40.0	23.0

Crosby® Grade 100 Alloy Chain Fittings

Crosby 8/10™



EN1677-4



A-1343 Welded Master Link

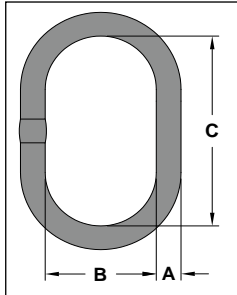

Size	A-1343 Stock No.	Weight Each (kg)	For use as Grade 100 Chain Sling		For use as Grade 80 Chain Sling		WLL (t)	Proof Load (kN)	Dimensions (mm)		
			Single Leg Chain Size (mm)	Double Leg Chain Size (mm)	Single Leg Chain Size (mm)	Double Leg Chain Size (mm)			A	B	C
12X1	1247069	0.30	6	—	6-7	6	1.6	4	12	60	120
13X2	1247076	0.36	7-8	6	8	7	2.5	6.3	13	60	120
17X3	1247087	0.86	10	7-8	10	8	4.1	10.3	17	90	160
19X4A	1247096	1.08	13	10	13	10	6.7	16.8	19	90	160
22X4B	1247115	1.59	13	10	16	13	8.5	21.3	22	90	170
25 X5	1247124	2.43	16	13	18-19	16	11.5	28.8	25	115	210
28X6	1247133	3.91	16-18	13	18-20	16	13	32.5	28	145	275
31X7	1247142	4.86	19-20	16	22-23	18-20	17	42.5	31	145	275
36X8	1247151	6.87	22-23	18-20	26	22-23	24	60	36	155	285
38X9	1247160	7.63	26	22-23	32	26	31.5	78.8	38	140	270
50X10A	1247165	17.6	32	26	—	32	45	112.5	50	200	380
57X10B	1247172	24.5	—	32	—	—	65.3	163.3	57	203	406



A-1346 Welded Master Link Assembly

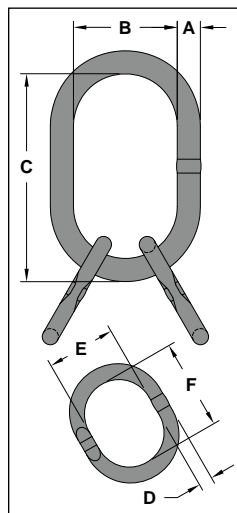

Size	A-1346 Stock No.	Weight Each (kg)	For use as Grade 100 Chain Sling Three and Four Legs Chain Size (mm)	For use as Grade 80 Chain Sling Three and Four Legs Chain Size (mm)	WLL (t)	Proof Load (kN)	Dimensions (mm)					
							A	B	C	D	E	F
17X1	1256868	1.58	6	7	4.1	10.3	17	90	160	13	60	120
19X2A	1256874	1.8	7	8	4.3	10.6	19	90	160	13	60	120
22X2B	1256883	3.35	8	10	6.7	16.8	22	100	180	17	90	160
25X3	1256892	5.51	10	10	8.9	22.3	25	146	275	19	90	160
28X4A	1256917	7.17	13	13	14.5	36.3	28	145	275	22	100	180
31X4B	1256926	9.72	13	16	17	42.5	31	145	275	25	115	210
36X5	1256935	12.2	16	18-19	23.6	59	36	146	275	28	100	190
40X6	1256944	18.68	18	19-20	28.1	70.3	40	160	300	31	145	275
45X7	1256953	26.56	19-20	22-23	38.3	95.8	45	180	340	36	155	285
50X8	1256962	32.86	22-23	26	45	112.5	50	200	380	38	140	370
57X9	1256971	59.7	26	32	67	167.5	57	203	406	50	200	380
70	1014864*	88.9	32	32	98.4	192.9	70	251	457	70	251	457

* A-1345

Crosby® ELIMINATOR® Fittings



L-1361 Crosby ELIMINATOR® Single Hook

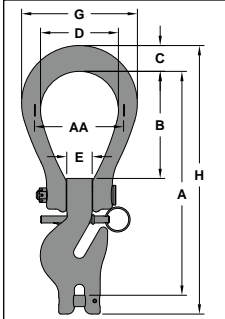

Chain Size (mm)	Frame Size	Working Load Limit (t)	L-1361 Stock No.	Weight Each (kg)	Dimensions (mm)							
					A	B	C	D	E	AA	G	H
7	2	2.0	1049802	1.76	208	99.0	22.9	76.2	23.9	89.0	112	248
8	2	2.6	1049809	1.76	208	99.0	22.9	76.2	23.9	89.0	112	248
10	3	4.0	1049818	2.94	255	122	29.5	88.9	28.7	102	132	306
13	4	6.8	1049827	6.12	327	152	41.4	105	33.3	127	162	395
16	5	10.3	1049836	10.9	388	175	49.8	121	41.4	152	188	472

L-1362 Crosby ELIMINATOR® Double Hook

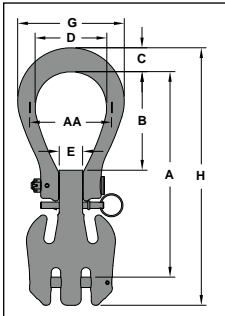

Chain Size (mm)	Frame Size	Working Load Limit (t)	L-1362 Stock No.	Weight Each (kg)	Dimensions (mm)							
					A	B	C	D	E	AA	G	H
7	2	3.9	1049913	2.13	208	99.0	22.9	76.2	23.9	89.0	112	257
8	2	5.0	1049922	2.13	208	99.0	22.9	76.2	23.9	89.0	112	257
10	3	8.0	1049931	3.67	255	122	29.5	88.9	28.7	102	132	319
13	4	13.6	1049940	7.84	327	152	41.4	105	33.3	127	162	413
16	5	20.5	1049949	14.3	388	175	49.8	121	41.4	152	188	491

Using Crosby ELIMINATOR® in 3 Leg Slings



Spectrum 10® Chain Size (mm)	Master Link A-1343 Stock No.	Crosby ELIMINATOR® Single L-1361 Stock No.	Crosby ELIMINATOR® Double L-1362 Stock No.
7	1247096	1049802	1049913
8	1247096	1049809	1049922
10	1247115	1049818	1049931
13	1247142	1049827	1049940
16	1247151	1049836	1049949

Use one of each when making three leg sling.

Using Crosby ELIMINATOR® in 4 Leg Slings



Spectrum 10® Chain Size (mm)	Master Link A-1343 Stock No.	Crosby ELIMINATOR® Single L-1361 Stock No.	Crosby ELIMINATOR® Double L-1362 Stock No.
7	1247096	–	1049913
8	1247096	–	1049922
10	1247115	–	1049931
13	1247142	–	1049940
16	1247151	–	1049949

Use two L-1362 fittings when making Quad leg sling.

Crosby® Grade 100 Chain Fittings

Crosby 8/10™



Fatigue Rated®

A-1337 LOK-A-LOY® 10 Alloy Connecting Link

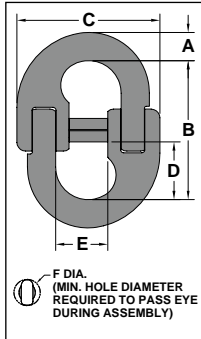

Chain Size (mm)	Working Load Limit (t)	A-1337 Stock No.	Weight Each (kg)	Dimensions (mm)					
				A	B	C	D	E	F
7	2.0	1015104	.12	9.7	49.3	48.3	20.6	17.5	14.5
8	2.5	1015113	.16	9.40	59.7	52.6	25.1	18.3	16.3
10	4.0	1015122	.34	12.2	68.6	62.7	28.4	22.9	19.8
13	6.8	1015136	.73	17.3	87.6	84.1	36.6	28.4	24.6
16	10.3	1015145	1.30	20.6	105	99.1	43.7	34.3	29.0
20	16.0	1015154	2.26	23.6	118	118	53.1	40.4	32.5
22	19.4	1015163	3.41	26.9	140	143	58.7	50.0	36.6
26	27.1	1015172	5.00	31.0	152	157	63.5	56.4	47.8
32	41.0	1015181	9.25	38.1	189	194	78.5	64.3	55.6

S-1325A Grade 100 Chain Coupler

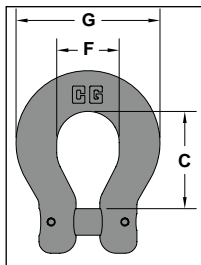

Chain Size (mm)	Working Load Limit (t)	S-1325A Stock No.	Weight Each (kg)	Dimensions (mm)		
				C	F	G
6	1.5	1098496	.11	26.2	19.3	44.7
7	2.0	1098500	.23	35.8	22.4	59.0
8	2.5	1098504	.23	35.6	22.4	59.0
10	4.0	1098508	.34	46.7	30.0	69.0
13	6.8	1098512	.75	55.6	38.1	94.5
16	10.3	1098516	.86	71.4	49.8	112

S-1311N Grade 100 Chain Shortener Link with Locking Device

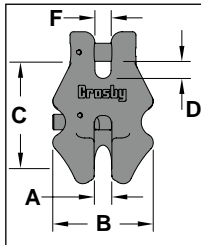

Chain Size (mm)	Working Load Limit (t)	S-1311N Stock No.	Weight Each (kg)	Dimensions (mm)				
				A	B	C	D	F
6	1.5	1017860	.34	7.6	44.7	46.5	7.4	7.4
7	2.0	1017869	.45	8.6	51.8	55.1	8.6	8.4
8	2.6	1017878	.45	10.2	59.9	64.3	9.9	9.6
10	4.0	1017897	.68	12.2	72.1	78.0	12.2	11.7
13	6.8	1017906	1.47	15.7	90.4	95.8	15.5	15.0
16	10.3	1017915	2.54	18.5	108	118	18.5	17.8

A-1338 Clevis Cradle Grab Hook

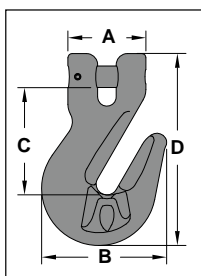

Chain Size (mm)	Working Load Limit (t)	A-1338 Stock No.	Weight Each (kg)	Dimensions (mm)			
				A	B	C	D
7	2.0	1049417	.20	43.7	64.5	55.9	98.5
8	2.6	1049426	.45	43.7	64.5	55.4	98.5
10	4.0	1049435	.82	47.0	78.5	65.5	119
13	6.8	1049444	1.78	60.7	97.3	83.3	149
16	10.3	1049453	3.18	67.8	115	97.8	179

Crosby® Grade 100 Chain Fittings

Crosby 8/10™

"QT"
QUENCHED & TEMPERED

Fatigue Rated

L-1338 Clevis Cradle Grab Hook with Latch

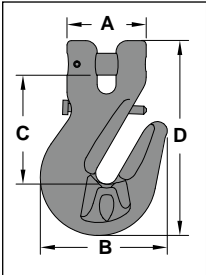

Chain Size (mm)	Working Load Limit (t)	L-1338 Stock No.	Weight Each (kg)	Dimensions (mm)				S-4338 Replacement Latch Kit Stock No.
				A	B	C	D	
7	2.0	1049480	.20	43.7	64.5	55.9	98.5	1048426
8	2.6	1049489	.45	43.7	64.5	55.4	98.5	1048426
10	4.0	1049498	.82	47.0	78.5	65.5	119	1048435
13	6.8	1049507	1.78	60.7	97.3	83.3	149	1048444
16	10.3	1049516	3.18	67.8	115	97.8	179	1048453

A-1358 Clevis Grab Hook

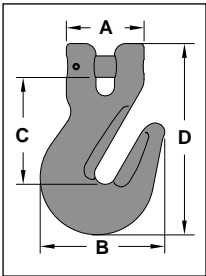

Chain Size (mm)	Working Load Limit (t)	A-1358 Stock No.	Weight Each (kg)	Dimensions (mm)			
				A	B	C	D
7	2.0	1049610	.20	43.7	64.5	55.9	98.5
8	2.6	1049629	.45	43.7	64.5	55.4	98.5
10	4.0	1049638	.82	47.0	78.5	65.5	119
13	6.8	1049647	1.78	60.7	97.3	83.3	149
16	10.3	1049656	3.18	67.8	115	97.8	179

L-1358 Clevis Grab Hook with Latch

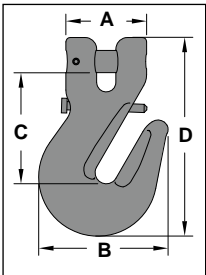

Chain Size (mm)	Working Load Limit (t)	L-1358 Stock No.	Weight Each (kg)	Dimensions (mm)				S-4338 Replacement Latch Kit Stock No.
				A	B	C	D	
7	2.0	1049605	.20	43.7	64.5	55.9	98.5	1048426
8	2.6	1049614	.45	43.7	64.5	55.4	98.5	1048426
10	4.0	1049623	.82	47.0	78.5	65.5	119	1048435
13	6.8	1049634	1.78	60.7	97.3	83.3	149	1048444
16	10.3	1049643	3.18	67.8	115	97.8	179	1048453

A-1328 Eye Grab Hook

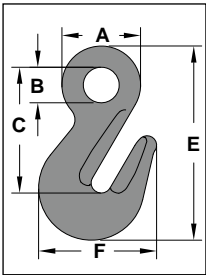

Chain Size (mm)	Working Load Limit (t)	A-1328 Stock No.	Weight Each (kg)	Dimensions (mm)				
				A	B	C	E	F
7-8	2.6	1026169	.98	44.5	19.1	70.9	109	66.3
10	4.0	1026187	1.6	52.3	23.9	84.6	130	78.5
13	6.8	1026196	3.3	65.0	28.4	104	162	97.3
16	10.3	1026205	6	78.0	33.3	125	194	115
18-20	16.0	1026214	10.0	82.6	38.1	137	223	152
22-23	20.0	1026223	13.1	100	46.0	165	257	166
26	27.1	1026232	18.9	113	50.8	183	291	197
32	41.0	1026241	39.4	143	60.5	231	371	241

A-1348 Eye Cradle Grab Hook

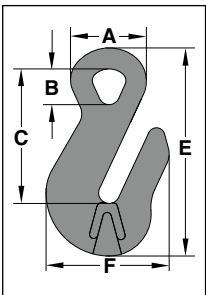

Chain Size (mm)	Working Load Limit (t)	A-1348 Stock No.	Weight Each (kg)	Dimensions (mm)				
				A	B	C	E	F
7-8	2.5	1026200	.35	36.3	16.5	64.0	98.2	58.2
10	4.0	1026209	.64	49.5	26.0	78.0	120	68.8
13	6.8	1026218	1.70	71.4	33.0	115	175	101
16	10.3	1026227	2.90	78.9	38.0	133	204	125



Crosby® Grade 100 SHUR-LOC® Hooks

Crosby 8/10™



Fatigue Rated®



EN1677-3

S-1317 SHUR-LOC® Clevis Hook

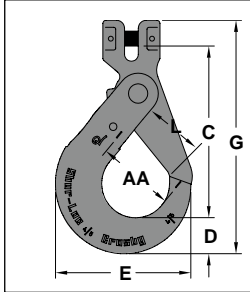

Chain Size (mm)	Working Load Limit (t)	S-1317 Stock No.	Weight Each (kg)	Dimensions (mm)					
				C	D	E	G	L	AA
6	1.5	1028991	.35	87.4	20.1	66.0	121	29.0	38.1
7	2.0	1029000	.82	114	27.9	89.0	159	35.1	51.0
8	2.6	1029009	.82	114	27.9	89.0	159	35.1	51.0
10	4.0	1029018	1.66	140	29.7	112	192	46.5	63.5
13	6.8	1029027	3.08	173	42.4	139	242	56.4	76.2
16	10.3	1029036	5.40	209	51.8	167	295	67.3	89.0
18-20	16.0	1029071	6.80	239	56.4	197	336	89.4	-
22	20.0	1029080	12.7	283	62.2	222	392	97.3	-
26	27.1	1029089	22.5	319	81.5	251	468	104	-

S-1316 SHUR-LOC® Eye Hook

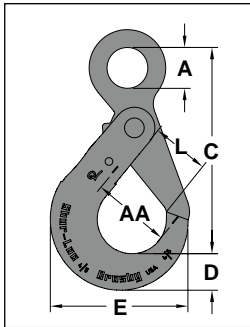

Chain Size (mm)	Working Load Limit (t)	S-1316 Stock No.	Weight Each (kg)	Dimensions (mm)					
				A	C	D	E	L	AA
6	1.5	1022896	.39	19.8	100	20.1	66.0	29.5	38.1
7-8	2.6	1022914	.82	27.4	135	27.9	88.9	37.6	51.0
10	4.0	1022923	1.54	33.0	167	29.7	112	46.5	63.5
13	6.8	1022932	2.72	41.9	209	42.4	139	56.4	76.2
16	10.3	1022941	6.85	55.9	256	51.8	167	67.3	89.0
18-20	16.0	1022942	8.62	66.0	274	56.4	197	89.4	-
22	20.0	1022943	12.7	72.9	317	62.2	222	97.3	-
26	27.1	1022944	22.5	80.0	371	81.5	251	104	-

S-1318A SHUR-LOC® Shank Hook

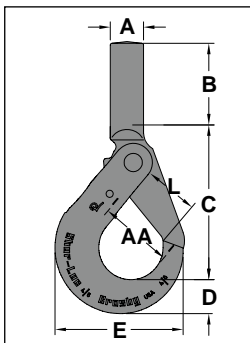

Chain Size (mm)	Grade 100 Alloy Chain Working Load Limit (t)	S-1318A Stock No.	Frame code	Weight Each (kg)	Dimensions (mm)						
					A†	B	C	D	E	L	AA
6	1.45	1098200	D	.45	20.1	55.0	84.0	20.1	66.0	28.7	38.1
7-8	2.59	1098209	G	.90	25.4	61.0	106	27.9	89.0	35.1	51.0
10	3.99	1098218	H	1.61	29.0	75.0	131	29.7	112	46.5	63.5
13	7.00	1098227	I	3.18	34.0	85.0	160	42.4	138	53.5	76.2
16	10.00	1098236	J	7.26	41.4	100	185	52.0	167	63.0	89.0

† Dimension before machining (as forged).

Crosby® Grade 100 SHUR-LOC® Swivel Hooks

Crosby 8/10™

QT
QUENCHED & TEMPERED

Fatigue Rated

QUIC-CHECK®

S-1326 SHUR-LOC® Swivel Hooks

- Suitable for infrequent, non-continuous rotation under load.

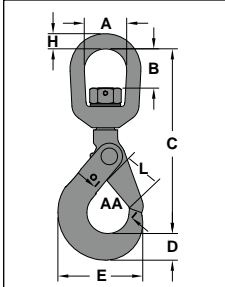

Chain Size (mm)	Grade 100 Alloy Chain Working Load Limit (t) 4:1	S-1326 Stock No.	Weight Each (kg)	Dimensions (mm)							
				A	B	C	D	E	H	L	AA
6	1.5	1004304	.57	38.1	33.5	189	20.1	66.0	12.7	28.7	38.1
7-8	2.6	1004313	1.18	44.5	40.4	235	27.9	88.9	16.0	35.1	51.0
10	4.0	1004322	2.13	50.8	43.9	274	29.7	112	19.1	44.5	63.5
13	6.8	1004331	3.92	63.5	60.5	351	42.4	139	25.4	53.6	76.2
16	10.3	1004340	7.71	69.9	64.3	410	51.8	167	28.7	63.2	89.0
18-20	16.0	1004349	10.9	71.9	64.0	442	56.4	197	27.9	89.4	127
22	20.0	1004358	13.2	87.4	81.0	418	62.2	222	33.0	97.3	152

S-13326 SHUR-LOC® Swivel Hooks with Bearing

- Suitable for frequent rotation under load.

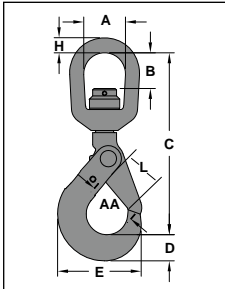

Chain Size (mm)	Grade 100 Alloy Chain Working Load Limit (t) 4:1	S-13326 Stock No.	Weight Each (kg)	Dimensions (mm)							
				A	B	C	D	E	H	L	AA
6	1.5	1004404	.57	38.1	29.0	157	20.1	66.0	12.7	28.7	38.1
7-8	2.6	1004413	1.18	44.5	38.6	192	27.9	89.0	16.0	35.1	51.0
10	4.0	1004422	2.13	51.0	40.9	226	29.7	112	19.1	46.5	63.5
13	6.8	1004431	3.92	63.5	51.6	282	42.4	138	25.4	53.5	76.2
16	10.3	1004440	7.71	70.0	50.3	320	52.0	167	28.7	63.0	89.0

Crosby® Grade 100 Hooks



EN1677-2

L-1339 Clevis Sling Hook

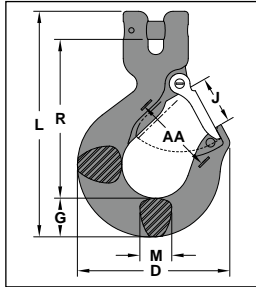

Chain Size (mm)	Working Load Limit (t)	Hook ID Code	L-1339 Stock No.	Weight Each (kg)	Dimensions (mm)							S-4320 Rep. Latch Stock No.	S-4339 Rep. Latch Stock No.
					D	G	J	L	M	R	AA		
6	1.4	DA	1049103	0.29	72.6	18.5	23.6	107	16.0	74.9	38.1	1096325	-
7	2.0	HA	1049112	0.72	98.0	26.4	30.2	144	19.1	101	50.8	1096468	-
8	2.5	HA	1049121	0.71	98.0	26.4	30.2	144	19.1	100	50.8	1096468	-
10	4.0	IA	1049130	1.17	111	30.2	38.9	171	25.4	120	63.5	1096515	-
13	6.7	JA	1049149	2.39	142	36.6	45.2	213	29.7	150	76.2	1096562	-
16	10.0	KA	1049158	4.45	172	48.0	61.2	259	36.6	177	102	1096609	-
18-20	15.6	-	1049167	8.30	211	71.9	68.3	332	50.0	203	114	-	1048714
22-23**	21.0	-	1049176	11.2	233	78.0	77.5	355	50.0	223	127	-	1048732

** 22-23 mm size does not have cam, latch attaches to unique pin.

L-1327 Eye Sling Hook

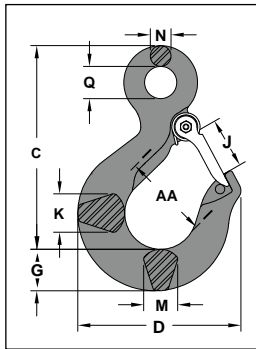

Chain Size (mm)	Working Load Limit (t)	Hook ID Code	L-1327 Stock No.	Weight Each (kg)	Dimensions (mm)									S-4320 Rep. Latch Stock No.
					C	D	G	J	K	M	N	Q	AA	
6	1.4	DA	1025860	.23	84.8	72.9	18.5	22.9	16.0	16.0	9.1	19.1	38.1	1096325
7 - 8	2.5	HA	1025869	.59	107	99.1	26.2	30.0	19.1	19.1	12.7	19.1	50.8	1096468
10	4.0	IA	1025878	1.04	127	110	30.2	38.9	30.2	25.4	14.2	23.9	63.5	1096515
13	6.7	JA	1025887	2.04	161	144	36.6	45.2	34.8	29.7	18.3	28.4	76.2	1096562
16	10.0	KA	1025896	3.81	189	172	47.8	60.5	42.2	36.6	22.4	33.3	102	1096609
18-20	15.6	K	1025915	6.80	230	189	57.2	58.2	47.8	41.4	28.2	62.0	102	1096609
22-23	21.0	L	1025924	9.39	256	211	65.8	63.5	55.6	49.3	32.3	72.1	102	1096657
26	26.5	N	1025933	17.9	326	262	76.2	83.8	68.3	60.5	39.6	88.9	127	1096704
32	40.0	P	1025942	47.6	462	357	116	108	95.3	81.0	50.8	114	178	1093717

A-1359 Clevis Foundry Hook

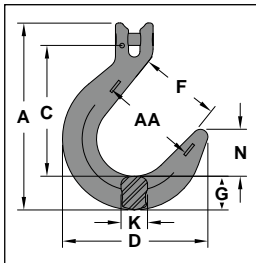

Chain Size (mm)	Working Load Limit at Saddle of Hook (t)	Working Load Limit at Tip of Hook (t)	A-1359 Stock No.	Weight Each (kg)	Dimensions (mm)							
					A	C	D	F	G	K	N	AA
7	2.0	1.0	1049907	0.98	159.0	111.3	122.4	63.5	28.7	22.4	39.9	88.9
8	2.6	1.3	1049911	0.93	159.0	111.0	122.4	63.5	28.7	22.4	39.9	88.9
10	4.0	2.0	1049916	1.95	197.1	140.7	147.8	76.2	35.1	33.0	47.8	101.6
13	6.8	3.4	1049925	3.62	238.3	169.4	178.8	88.9	41.4	38.1	57.2	114.3
16	10.3	5.1	1049934	6.44	285.8	195.1	207.5	101.6	55.6	44.5	64.3	127.0
18-20	16.0	8.0	1049943	11.2	366.5	248.7	245.1	127.0	61.0	55.9	86.1	152.4
22-23	21.0	10.0	1049952	19.9	412.8	279.9	280.2	139.7	78.0	69.1	95.0	165.1

A-1329 Eye Foundry Hook

- Hook can be tip loaded at the reduced Working Load Limit – see below. Operator must ensure the load is retained properly in the hook.

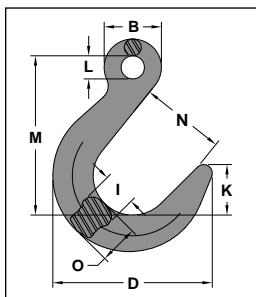

Chain Size (mm)	Working Load Limit at Saddle of Hook (t)	Working Load Limit at Tip of Hook (t)	A-1329 Stock No.	Weight Each (kg)	Dimensions (mm)							
					B	D	I	K	L	M	N	O
7-8	2.6	1.3	1026280	1.09	39.6	122.4	22.4	39.9	16.0	122.2	63.5	28.7
10	4.0	2.0	1026289	2.04	52.6	147.8	33.0	47.8	20.6	139.7	76.2	35.1
13	6.8	3.4	1026297	3.22	64.3	178.8	38.1	57.2	26.2	180.6	88.9	41.4
16	10.3	5.1	1026306	5.53	76.2	207.5	44.5	64.3	31.8	202.2	101.6	55.6
18-20	16.0	8.0	1026315	8.75	104.9	245.1	55.9	86.1	50.0	273.1	127.0	61.0
22-23	20.0	10.0	1026324	11.9	121.2	280.2	69.1	95.0	57.9	311.2	139.7	78.0
26	27.1	13.5	1026333	23.4	135.4	302.3	71.9	99.8	65.0	339.6	152.4	84.1
32	41.0	20.5	1026342	38.4	167.9	336.6	88.9	110.0	80.0	387.4	165.1	97.5

Crosby® Grade 100 Hooks

Crosby 8/10™ "QT" QUENCHED & TEMPERED Fatigue Rated

A-1355 Chain Choker Hook

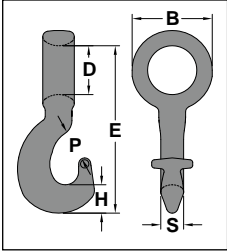

Chain Size (mm)	Working Load Limit (t)	A-1355 Stock No.	Weight Each (kg)	Dimensions (mm)					
				B	D	E	H	P	S
7-8	2.6	1015204	.34	52.1	30.0	123	20.1	17.5	16.5
10	4.0	1015213	.74	67.6	39.9	154	23.6	23.6	17.5
13	6.8	1015222	1.42	85.1	51.6	193	30.0	32.0	23.8
16	10.3	1015231	3.16	107	64.0	246	39.1	28.4	30.0

A-1370 Reeving Link

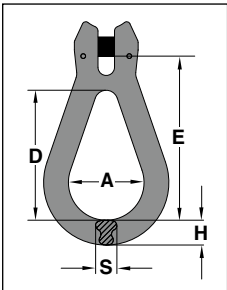

Chain Size (mm)	Working Load Limit (t)	A-1370 Stock No.	Weight Each (kg)	Dimensions (mm)				
				A	D	E	H	S
7-8	2.5	1012000	.26	39.0	67.5	90.0	16.0	10.0
10	4.0	1012009	.50	49.0	85.5	108	17.0	14.0
13	6.8	1012018	1.10	62.5	108	138	21.0	18.0
16	10.3	1012027	2.55	79.0	139	180	30.5	25.5



Sling Identification Tag Kits

Stamped ID Tag

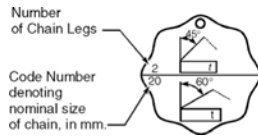

Stamped ID Tags

- Octagonal metal sling tag.
- Prestamped - easy to add sling length, Working Load Limit, name, etc.
- Front side is shown - reverse is blank.
- Available with or without welded attached ring.
- Attaching ring size is 5mm x 50mm.
- Available completely blank for wire rope sling applications.

ID Tag Stock No. with Ring	ID Tag Stock No. without Ring	Application
1152445	1200829	For single leg sling: 90°
1152444	1200830	For multi-leg sling: 45°/60°
1152514	1200837	Blank Tag

RFID Equipped Tags

ID Tags

- Heavy Duty tags.
- Chain tags meet requirements of EN818 for Sling Identification.
- Raised edge and recessed pads to protect lettering.
- Raised lettering for quick reference.



(#115355)



(#115350)



Stock No.	Material Type	RFID Equipped	Tag Size (mm)	Weight Each (kg)
115350	Cast Stainless Steel	Yes	43 x 33.3	.03
115355*	Stamped Zinc Plated Steel	Yes	43 x 33.3	.04

* Patent pending.

Crosby® Replacement Kits

Clevis Pin Replacement Kits



Chain Size (mm)	A-1362	A-1337	A-1361, S-1325A, S-1311N, A-1338, L-1338, A-1358, L-1358, S-1317,	A-1359
			L-1339	
6	—	—	1091792	—
7	1092713	1087690	1091801	1091884
8	1092722	1087595	1091810	1091885
10	1092731	1087692	1091829	1091829
13	1092740	1087693	1091838	1091838
16	1092759	1087694	1091847	1091847
18	—	—	1091897	1091897
20	—	1087702	1091897	1091897
22	—	1087703	1091887	1091887
23	—	—	—	1091887
26	—	1087704	1091888	—
32	—	1087705	—	—

Hook Latch / Locking Pin Replacement Kits

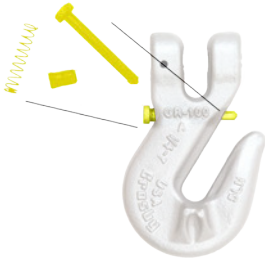

Chain Size (mm)	A-1361	A-1362	S-1311N	L-1338, L-1358	L-1339	L-1327
6	—	—	1264009	—	1096325	1096325
7	1092983	1092983	1264018	1048426	1096468	1096468
8	1092983	1092983	1264027	1048426	1096468	1096468
10	1092992	1092992	1264036	1048435	1096515	1096515
13	1093001	1093001	1264045	1048444	1096562	1096562
16	1093010	1093010	1264054	1048453	1096609	1096609
18	—	—	—	—	1048714	1096609
20	—	—	—	—	1048714	1096609
22	—	—	—	—	1048732*	1096657
23	—	—	—	—	1048732*	1096657
26	—	—	—	—	—	1096704
32	—	—	—	—	—	1093717

* 22-23 mm sizes do not have a cam. The latch attaches to a unique pin.

SHUR-LOC® Hook Trigger Replacement Kits



Chain Size (mm)	S-1317, S-1316, S1318A, S-1326, S13326
6	6603010
7	6603011
8	6603011
10	6603012
13	6603013
16	6603014
18	6603007
20	6603007
22	6603008
26	6603009

Hinge Bolt Replacement Kits

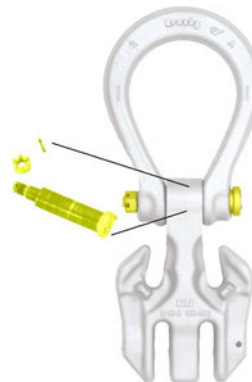

Chain Size (mm)	A-1361, A-1362
7	1092916
8	1092916
10	1092925
13	1092934
16	1092943

Crosby® Grade 80 Alloy Chain

GRADE 80 to EN818-2 Working Load Limit – 4 to 1 Design Factor

Nominal Size of Sling (mm)	Single Leg (t)	Two Leg Slings		Triple and Four-Leg Slings		Choker Hitch *
		0° < β ≤ 45° (t)	45° < β ≤ 60° (t)	0° < β ≤ 45° (t)	45° < β ≤ 60° (t)	
6	1,12	1,60	1,12	2,36	1,70	0,90
7	1,50	2,12	1,50	3,15	2,24	1,20
8	2	2,80	2	4,25	3	1,60
10	3,15	4,25	3,15	6,70	4,75	2,50
13	5,30	7,50	5,30	11,20	8	4,25
16	8	11,20	8	17	11,80	6,40
19-20	11,20	16	11,20	23,60	17	9
22	15	21,20	15	31,50	22,40	12
23	16	23,60	16	35,50	25	12,80
26	21,20	30	21,20	45	31,50	17
32	31,50	45	31,50	67	47,50	25,20

* For choker applications, the Working Load Limit must be reduced by 20%. The Crosby A-1338 cradle grab hook does not require any reduction of the Working Load Limit. The design factor of 4 to 1 on Spectrum® 8 Alloy Chain agrees with the design factor used by the International Standards Organization (I.S.O.) and ANSI B30.9 and is the preferred set of Working Load Limit values to be used.













Grade 80 Alloy Chain Recommended for Overhead Lifting Applications



Chain Size (mm)	Spec. 8 Drum Stock No.	Meters Per Drum	Dimensions (mm)	Working Load Limit (t)	Weight Per Meter (kg)
6	1244915	200	6 x 18	1.1	.80
7	1244985	200	7 x 21	1.5	1.05
8	1245055	200	8 x 24	2.0	1.25
10	1245125	200	10 x 30	3.2	2.20
13	1245195	150	13 x 39	5.3	3.80
16	1245265	100	16 x 48	8.0	5.70
18	1245305	50	18 x 54	10.0	7.30
19-20	1245356	50	19 x 57	11.2	8.03
20	1245396	50	20 x 60	12.5	9.00
22	1245426	50	22 x 66	15.0	10.90
23	1245453	50	23 x 69	16.0	10.90
26	1245496	50	26 x 78	21.2	15.20
32	1245514	20	32 x 96	31.5	23.00

Grade 80 Assembly Chart

SINGLE LEG SLING

Spectrum 8 ^o Chain Size (mm)													
	Grade 80 Chain Stock No.	Master Link with Flat A-344 Stock No.	Master Link Assembly A-347 Stock No.	ELIMINATOR [®] L-1361 Stock No.	LOK-A-LOY [®] A-1337 Stock No.	Chain Coupler S-1325 Stock No.	Clevis Sling Hook L-1339 Stock No.	SHUR-LOC [®] Clevis Hook S-1317 Stock No.	Latching Clevis Chain Hook S-314A Stock No.	Clevis Grab Hook A-338 Stock No.	Cradle Grab Hook A-1338* Stock No.	Eye Sling Hook L-1327 Stock No.	Clevis Foundry Hook A-1359 Stock No.
7	1244985	1256862	—	1049802	1015104	1098500	1049112	1029000	1225021	1027659	1049417	1025869	1049907
8	1245055	1256932	—	1049809	1015113	1098504	1049121	1029009	1225021	—	1049426	1025869	1049911
10	1245125	1257002	—	1049818	1015122	1098508	1049130	1029018	1225091	1027677	1049435	1025878	1049916
13	1245195	1257072	—	1049827	1015136	1098512	1049149	1029027	1225161	1027686	1049444	1025887	1049925
16	1245265	1257212	—	1049836	1015145	1098516	1049158	1029036	1225162	1027695	1049453	1025896	1049934
19-20	1245356	1257382	—	—	1015154	—	1049167	1029071	—	1027702	—	1025915	1049943
22	1245426	1257422	—	—	1015163	—	1049176	1029080	—	1027711	—	1025924	1049952
26	1245496	1257492	—	—	1015172	—	—	1029089	—	—	—	1025933	—
32	1245566	1257632	—	—	1015181	—	—	—	—	—	—	1025942	—

DOUBLE LEG SLING

Spectrum 8 ^o Chain Size (mm)	Grade 80 Chain Stock No.	Master Link with Flat A-344 Stock No.	Master Link Assembly A-347 Stock No.	ELIMINATOR [®] L-1362 Stock No.	LOK-A-LOY [®] A-1337 Stock No.	Chain Coupler S-1325 Stock No.	Clevis Sling Hook L-1339 Stock No.	SHUR-LOC [®] Clevis Hook S-1317 Stock No.	Latching Clevis Chain Hook S-314A Stock No.	Clevis Grab Hook A-338 Stock No.	Cradle Grab Hook A-1338* Stock No.	Eye Sling Hook L-1327 Stock No.	Clevis Foundry Hook A-1359 Stock No.
8	1245055	1257002	—	1049922	1015113	1098504	1049000	1029009	1225021	—	1049426	1025869	1049911
10	1245125	1257072	—	1049931	1015122	1098508	1049009	1029018	1225091	1027677	1049435	1025878	1049916
13	1245195	1257212	—	1049940	1015136	1098512	1049018	1029027	1225161	1027686	1049444	1025887	1049925
16	1245265	1257282	—	1049949	1015145	1098516	1049027	1029036	1225162	1027695	1049453	1025896	1049934
19-20	1245356	1257492	—	—	1015154	—	1049036	1029071	—	1027702	—	1025915	1049943
22	1245426	1257492	—	—	1015163	—	1049045	1029080	—	1027711	—	1025924	1049952
26	1245496	1257562	—	—	1015172	—	—	1029089	—	—	—	1025933	—
32	1245566	1257632	—	—	1015181	—	—	—	—	—	—	1025942	—

TRIPLE AND QUADRUPLE LEG SLING

Spectrum 8 ^o Chain Size (mm)	Grade 80 Chain Stock No.	Master Link with Flat A-344 Stock No.	Master Link Assembly A-347 Stock No.	ELIMINATOR [®] Stock No.	LOK-A-LOY [®] A-1337 Stock No.	Chain Coupler S-1325 Stock No.	Clevis Sling Hook L-1339 Stock No.	SHUR-LOC [®] Clevis Hook S-1317 Stock No.	Latching Clevis Chain Hook S-314A Stock No.	Clevis Grab Hook A-338 Stock No.	Cradle Grab Hook A-1338* Stock No.	Eye Sling Hook L-1327 Stock No.	Clevis Foundry Hook A-1359 Stock No.	
														7
8	1245055	—	1257972	1015113	1098504	1049000	1029009	1225021	—	1049426	1025869	1049911		
10	1245125	—	1258142	1015122	1098508	1049009	1029018	1225091	1027677	1049435	1025878	1049916		
13	1245195	—	1258182	1015136	1098512	1049018	1029027	1225161	1027686	1049444	1025887	1049925		
16	1245265	—	1258332	1015145	1098516	1049027	1029036	1225162	1027695	1049453	1025896	1049934		
19-20	1245356	—	1258402	1015154	—	1049036	—	—	1027702	—	1025915	1049943		
22	1245426	—	1258462	1015163	—	1049045	—	—	1027711	—	1025924	1049952		
26	1245496	—	—	1015172	—	—	—	—	—	—	—	1025933	—	
32	1245566	—	—	1015181	—	—	—	—	—	—	—	1025942	—	

* Available with latch.

Grade 80 Welded Master Links



EN1677-4

A-344 Welded Master Link

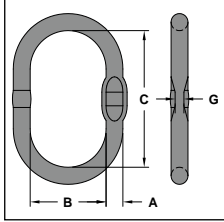

Size (mm)	A-344 Stock No.	Weight Each (kg)	Single Leg Chain Sling (mm)	Double Leg Chain Sling (mm)	WLL (t)*	Dimensions (mm)				Engineered Flat Size for S-1325A (mm)
						A	B	C	G	
12	1256862	.30	6-7	6	1.6	12.0	60.0	120	6.50	6
13	1256932	.36	8	7	2.5	13.0	60.0	120	6.50	7-8
17	1257002	.86	10	8	4.1	17.0	90.0	160	8.50	10
19	1257072	1.08	13	10	6.7	19.0	90.0	160	8.50	10
20	1257082	1.17	—	—	6.7	20.0	80.0	150	—	—
22	1257214	1.59	—	—	8.5	22.0	90.0	170	—	—
22	1257212	1.63	16	13	8.5	22.0	100	180	10.5	13
22	1257215	2.39	—	—	6.3	22.0	145	275	—	—
25	1257282	2.43	18-19	16	11.5	25.0	115	210	13.5	16
25	1257302	2.31	—	—	11.5	25.0	100	190	—	—
25	1257332	3.35	—	—	8.9	25.0	145	275	—	—
28	1257352	3.22	—	—	12.9	28.0	110	210	—	—
28	1257382	3.91	20	—	13.0	28.0	145	275	13.5	16
31	1257422	4.86	22	18-19	17.0	31.0	145	275	15.5	—
32	1257442	5.30	—	—	17.0	32.0	140	270	—	—
36	1257492	6.87	25-26	20-22	24.0	36.0	155	285	—	—
38	1257502	7.63	—	—	31.5	38.0	140	270	—	—
40	1257532	8.96	28	—	28.1	40.0	160	300	—	—
45	1257569	10.31	—	—	32.0	45.0	140	250	—	—
45	1257564	12.70	—	—	38.3	45.0	170	320	—	—
45	1257562	12.82	32	25-26	38.3	45.0	180	340	—	—
50	1257582	17.60	—	—	45.0	50.0	200	380	—	—
51	1257632	18.72	—	32	45.0	51.0	215	390	—	—
57+	1257652	24.5	—	—	65.3	57.0	203	406	—	—

* Chain slings require that the Minimum Ultimate Load be 4 times the Working Load Limit.

† Forged

A-347 Welded Master Link Assembly

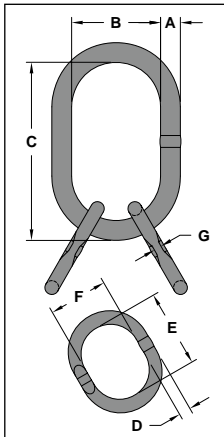

Size (mm)	A-347 Stock No.	Weight Each (kg.)	Three and Four Leg Chain Sling (mm)	WLL (t)*	Dimensions (mm)							Engineered Flat Size for S-1325 (mm)
					A	B	C	D	E	F	G	
13/12	1257692	.82	6	2.4	13.0	60.0	120	12.0	85.0	45.0	6.00	6
17/13	1257762	1.58	7	4.1	17.0	90.0	160	13.0	120	60.0	6.50	7
19/13	1257832	1.80	8	4.3	19.0	90.0	160	13.0	120	60.0	6.50	8
22/20	1257977	3.93	—	8.5	22.0	90.0	170	20.0	150	80.0	—	—
22/17	1257972	3.35	10	6.7	22.0	100	180	17.0	160	90.0	8.50	10
22/16	1257979	3.53	—	5.8	22.0	145	275	16.0	120	60.0	—	—
25/20	1258122	4.65	—	10.7	25.0	100	190	20.0	150	80.0	—	—
25/19	1258102	5.51	—	8.9	25.0	145	275	19.0	160	90.0	—	—
28/22	1258162	6.40	—	12.9	28.0	110	210	22.0	170	90.0	—	—
28/22	1258142	7.17	13	14.5	28.0	145	275	22.0	180	100	10.5	13
31/25	1258182	9.72	16	17.0	31.0	145	275	25.0	210	115	13.5	16
32/25	1258202	9.92	—	17.0	32.0	140	270	25.0	190	100	—	—
36/28	1258222	12.20	—	23.6	36.0	145	275	28.0	190	100	—	—
38/32	1258224	18.23	—	28.1	38.0	140	270	32.0	270	140	—	—
40/31	1258332	18.68	19	28.1	40.0	160	300	31.0	275	145	15.5	—
45/38	1258422	27.96	—	38.3	45.0	170	320	38.0	270	140	—	—
45/36	1258402	26.56	22	38.3	45.0	180	340	36.0	285	155	—	—
50/38	1258442	32.86	—	45.0	50.0	200	380	38.0	270	140	—	—
51/45	1258462	42.92	26	45.0	51.0	190	350	45.0	340	180	—	—
57/50+	1258482	59.70	—	67.0	57.0	203	406	50.0	380	200	—	—

* Chain slings require that the Minimum Ultimate Load be 4 times the Working Load Limit.

† Forged

Alloy Fittings Application and Information

HOW TO ASSEMBLE AN S-1325 COUPLER LINK ON TO MASTER LINK



1. Slide Coupler Link over Engineered Flat of Master Link.



2. Rotate Coupler Link so that clevis fitting is to the outside of Master Link and attach to chain sling.

HOW TO ASSEMBLE A CROSBY CLEVIS TYPE FITTING



1. Place chain link into clevis of chain coupler. Insert pin fully into the clevis ears.



2. Place the coupler link on its side and using a hammer, drive the locking pin into the clevis ear until it is flush with the outside surface.

HOW TO ASSEMBLE A LOK-A-LOY® CONNECTING LINK

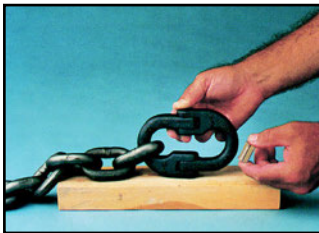

1. Place the locking sleeve between the assembled half link forgings.



2. Drive the pin through the assembled link ends and sleeve until the end of the pin is flush with the outside of the connecting link halves.

HOW TO ASSEMBLE LOAD PIN IN CROSBY ELIMINATOR® FITTINGS



1. Place both chain links into clevis slots of fitting, insert pin fully into the two-leg clevis.



2. Place Eliminator assembly on a firm surface. Using a hammer, drive the locking pin into the two-leg clevis until it is flush with the top of the hole.

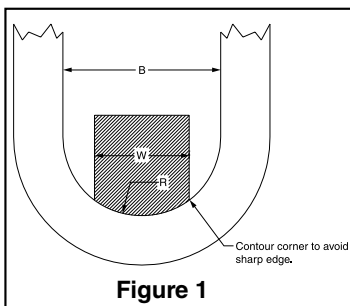

Figure 1

Crosby master links and master link assemblies are proof tested with special fixtures in accordance with ASTM A952. While other specifications such as EN 1677-4 Recommended Guideline for Proof Test Procedures for Slings related to master link and master link assemblies also allow for the use of special fixtures when proof testing, Crosby follows the guidelines set forth in ASTM A952. The purpose of the special fixture is to prevent localized point loading during the proof test. Point loading at the proof test load may result in permanent deformation. The proof test fixture per ASTM A952 allows for a maximum fixture width (W) of 60% of the inside width (B) of the master link. The radius of the fixture (R) is one-half of inside width of the master link. A sketch showing an example of the special fixture is shown in Figure 1. Note that the corner of the fixture should be contoured so that a sharp edge does not make contact with the master link during the loaded condition.

Over the years some master links and master link assemblies have changed dimensions and working load limits. Special consideration should be given to the actual inside width of the master link being tested and its correct allowable proof load value. If the correct allowable proof load value is in question, then Crosby Engineering should be consulted for the appropriate proof load value.

ALLOY STEEL CHAIN SLINGS AND CROSBY ELIMINATOR®

Warning, Selection, Use and Maintenance Information

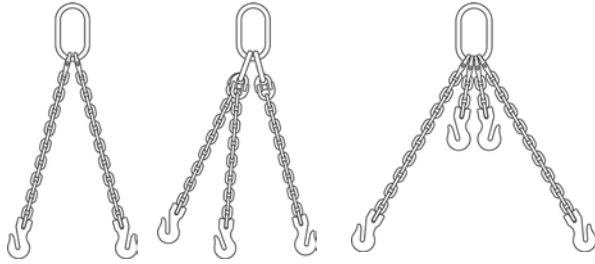

WARNING

- Loads may disengage from sling if proper rigging procedures and inspection are not followed.
- A falling load may cause serious injury or death.
- Inspect sling for damage before each use.
- Do not attempt to use sling above rated load and angle upon which it is based.
- Consult sling load chart for capacity reduction due to sling angle or type of hitch used.
- Read and understand these instructions before using sling.

Important Safety Information Read and Follow

These warnings and instructions are applicable to alloy chain slings produced from Crosby Grade 8 (80) and Grade 10 (100) chain and components.

- Only alloy chain, grade 80 (Crosby Spectrum 8®), or grade 100 (Crosby Spectrum 10®), should be used for overhead lifting applications.
- Working Load Limit (WLL) is the maximum load in pounds which should ever be applied to chain, when the chain is new or in "as new" condition, and when the load is uniformly applied in direct tension to a straight length of chain.
- Working Load Limit (WLL) is the maximum working load for a specific minimum sling angle, measured from the horizontal plane. The minimum sling angle and Working Load Limit is identified on the sling.
- The Working Load Limit or Design factor may be affected by wear, misuse, overloading, corrosion, deformation, intentional alterations, sharp corner cutting action and other use conditions.
- Shock loading and extraordinary conditions must be taken into account when selecting alloy chain slings.
- See EN1677, OSHA Regulation for Slings 1910.184, ANSI/ASME B30.9-"SLINGS", ANSI/ASME B30.10-"HOOKS", and ANSI/ASME B30.26 "RIGGING HARDWARE" for additional information.

ASME B30.9 requires a designated person inspect each new sling and attachments prior to initial use, as well as the user or other designated person perform a visual inspection on a sling each day it is used. In addition, a periodic inspection shall be performed by a designated person at least annually, and shall maintain a record of the last inspection. For further inspection information, see Chain Inspection section of this document, or refer to ASME B30.9-1.9.

CAUSE FOR REMOVAL FROM SERVICE

A sling shall be removed from service if any of the following are visible on chain or attachments:

- Wear, nicks, cracks, breaks, gouges, stretch, bend, weld splatter, discoloration from excessive temperature, and throat openings of hooks.

- Chain links and attachments that do not hinge freely to adjacent links.
- Latches on hooks, if present, that do not hinge freely, seat properly or show evidence of permanent distortion.
- Excessive pitting or corrosion
- Missing or illegible sling identification
- Makeshift fasteners, hooks, or links formed from bolts, rods, etc.
- Mechanical coupling links in the body of the chain
- Other damage that would cause a doubt as to the strength of the chain.

OPERATING PRACTICES

- The weight of the load must be known, calculated, estimated or measured. The loading on the slings will depend on where the center of gravity is located.
- Select sling having suitable characteristics for the type of load, hitch and environment.
- Slings shall not be loaded in excess of the rated capacity.
- Consideration shall be given to the sling load angle which affects rated capacity. (See load chart Table 4 for Grade 100 (SPECTRUM 10®) and Table 5 for Grade 80 (SPECTRUM 8®).
- Never rig a sling with an angle greater than 60 degrees to vertical.
- Slings in a basket hitch should have the load balanced to prevent slippage.
- The sling shall be hitched in a manner providing control of the load.
- Never side load, back load, or tip load a hook.
- Always make sure the hook supports the load. The latch must never support the load.
- Read and understand Crosby hook and hook latch Warnings and Application Instructions.
- For two legged slings with angles greater than 90 degrees, use an intermediate link such as a master link or bolt type shackle to collect the legs of the slings. The intermediate link can be placed over the hook to provide an in-line load on the hook. This approach must also be used when using slings with three or more legs.
- When using chain slings in choker applications, the Working Load Limit must be reduced by 20%. Crosby recommends a minimum angle of choke of 120 degrees (see Figure 1). Consult the manufacturer when planning to use an angle of choke less than 120 degrees. If Crosby A-1338 Cradle Grab hooks are used at the minimum angle of choke of 120 degrees, the full sling rated WLL can be utilized.
- In shortening applications, a 20% reduction of the Working Load Limit is required except when using the Crosby A-1338 Cradle Grab Hooks, S-1311 Chain Shortener Link or the Crosby ELIMINATOR® shortener link. They can be used without any reduction to the Working Load Limit.
- Slings should always be protected from being damaged by sharp corners.
- Slings should not be dragged on the floor or over abrasive surface.
- Chain sling links should not be twisted or kinked.
- Slings should not be pulled from under loads if the load is nesting on the sling.

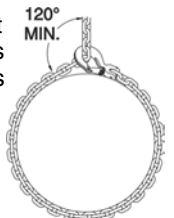

Figure 1

- Slings that appear to be damaged should not be used unless inspected and accepted by designated person.
- Personnel, including portions of the human body, should be kept from between the sling and the load, and from between the sling and the crane hook or hoist hook.
- Personnel shall stand clear of the suspended load.
- Personnel shall not ride the sling.
- Shock loading should be avoided.
- Twisting or kinking the legs (branches) should be avoided.
- During lifting, with or without the load, personnel should be alert for possible snagging.
- When using a basket hitch, the legs of the sling should contain or support the load from the sides, above the center of gravity, so that the load remains under control.
- Sling shall be long enough so that the rated capacity of the sling is adequate when the angle of the legs (branches) is taken into consideration. (See Table 4 for Grade 100 Chain and Table 5 for Grade 80 Chain).

General Usage

It must be recognized that certain factors in the usage of chain and attachments can be abusive and lessen the load that the chain or attachments can withstand. Some examples are twisting of the chain; disfigurement; deterioration by straining, usage, weathering and corrosion; rapid application of load or jerking; applying excessive loads; sharp corner cutting action and non-symmetrical loading effects.

Environmental Effects

- Excessive high or low temperatures or exposure to chemically active environments such as acid or corrosive liquids or fumes can reduce the performance of the chain and components.
- Extreme temperature will reduce the performance of alloy steel chain slings.
- Normal operating temperature is -40°F to 400°F (-40°C to 204°C).
- Reference temperature exposure chart to determine reduction of WLL due to operating at, and after exposure to, elevated temperatures (see Table 1 for Grade 80 Chain and Table 2 for Grade 100 chain).
- Chemically active environments can have detrimental effects on the performance of chain. The effects can be both visible loss of material and undetectable material degradation causing significant loss of strength.

Special Surface Coating/Plating/Galvanizing

- Chain should not be subjected to galvanizing, or any plating process. If it is suspected the chain has been exposed to chemically active environment, remove from service.

Temperature of Chain		Temporary Reduction of Rated Load at Elevated Temperature*	Permanent Reduction of Rated Load After Exposure to Temperature**
(F°)	(C°)		
Below 400	Below 204	None	None
400	204	10%	None
500	260	15%	None
600	316	20%	5%
700	371	30%	10%
800	427	40%	15%
900	482	50%	20%
1000	538	60%	25%
Over 1000	Over 538	OSHA 1910.184 requires all slings exposed to temperatures over 1000° F to be removed from service.	

* Crosby does not recommend the use of Alloy Chain at temperatures above 800° F.
** When chain is used at room temperature after being heated to temperatures shown in the first column.

Temperature		Temporary Reduction of Rated Load at Elevated Temperature*	Permanent Reduction of Rated Load After Exposure to Temperature**
(F°)	(C°)		
Below 400	Below 204	None	None
400	204	15%	None
500	260	25%	5%
600	316	30%	15%
700	371	40%	20%
800	427	50%	25%
900	482	60%	30%
1000	538	70%	35%
Over 1000	Over 538	OSHA 1910.184 requires all slings exposed to temperatures over 1000 F to be removed from service.	

* Crosby does not recommend the use of Alloy Chain at temperatures above 800° F.
** When chain is used at room temperature after being heated to temperatures shown in the first column.

CHAIN INSPECTION INSPECTION AND REMOVAL FROM SERVICE PER EN818/ASME B30.9

Refer to EN818 or ASME B30.9-1.9 for further information

Frequent Inspection

- A visual inspection for damage shall be performed by the user or designated person each day the sling is used.
- Conditions such as those listed in EN818 or ASME B30.9-1.9.4 Removal Criteria, or any other condition that may result in a hazard, shall cause the sling to be removed from service. Slings shall not be returned to service until approved by a qualified person.
- Written records are not required for frequent inspections.

Periodic Inspection

- A complete inspection for damage of sling shall be periodically performed by a designated person. Each link and component shall be examined individually, taking care to expose and examine all surfaces including the inner link surface. The sling shall be examined for conditions such as those listed in EN818 or ASME B30.9-1.9.4 Removal Criteria, and a determination made as to whether they constitute a hazard.
- Periodic Inspection Frequency: Periodic inspection intervals shall not exceed one year. The frequency of periodic inspections should be based on:
 - Frequency of sling use
 - Severity of service conditions
 - Nature of lifts being made
 - Experience gained on the service life of slings used in similar circumstances.

Guidelines for the interval are:

- Normal Service – yearly
 - Severe Service – monthly to quarterly
 - Special Service – as recommended by a qualified person
- Written records of the most recent periodic inspection shall be maintained, and shall include the condition of the sling.

Removal Criteria

An alloy sling chain shall be removed from service if conditions such as the following are present:

- Missing or illegible sling identification.
- Cracks or breaks
- Excessive wear, nicks, or gouges. Minimum thickness on chain link shall not be below the values listed in Table 3.
- Stretched chain links or components.

- e. Bent, twisted, or deformed chain links or components
- f. Evidence of heat damage.
- g. Excessive pitting or corrosion.
- h. Lack of ability of chain or components to hinge (articulate) freely.
- i. Weld spatter.
- j. For hooks, removal criteria as stated in EN1677 or ASME B30.10
- k. Other conditions, including visible damage, that cause doubt as to the continued use of the sling.

- f. Mechanical coupling links shall not be used within the body of an alloy chain sling to connect two pieces of chain.
- g. Modifications or alterations to the sling or components shall be considered as repairs and shall conform to all other provisions of EN1677 or ASME B30.9.
- h. All repairs shall comply with the proof test requirements of EN1677 or ASME B30.9 Section 9-1.6.

Repair

- a. Slings shall be repaired only by the sling manufacturer or a qualified person.
- b. A repaired sling shall be marked to identify the repairing agency per EN818 or ASME B30.9 Section 9-1.7.
- c. Chain and components used for sling repair shall comply with the provisions of EN1677 or ASME B30.9.
- d. Repair of hooks shall comply with EN1677 or ASME B30.10.
- e. Cracked, broken or bent chain links or components other than hooks shall not be repaired; they shall be replaced.

Nominal Chain Size		Minimum Thickness	
(in.)	(mm)	(in.)	(mm)
7/32	5.5	0.189	4.80
9/32	7	0.239	6.07
5/16	8	0.273	6.93
3/8	10	0.342	8.69
1/2	13	0.443	11.26
5/8	16	0.546	13.87
3/4	20	0.687	17.45
7/8	22	0.750	19.05
1	26	0.887	22.53
1-1/4	32	1.091	27.71

Refer to ASME B30.9

Table 4
Grade 100 (Spectrum 10®) Alloy Chain Working Load Limit — 4 to 1 Design Factor

Nominal Size of Sling (mm)	Single Leg (t)	Two Leg Slings		Triple and Four-Leg Slings		Choker Hitch (t)*
		0° < β ≤ 45° (t)	45° < β ≤ 60° (t)	0° < β ≤ 45° (t)	45° < β ≤ 60° (t)	
6	1,40	2,00	1,40	3,00	2,12	2,24
7	2,00	2,80	2,00	4,20	3,00	3,20
8	2,50	3,55	2,50	5,30	3,75	4,00
10	4,00	5,60	4,00	8,00	6,00	6,40
13	6,70	9,50	6,70	14,0	10,0	10,70
16	10,0	14,0	10,0	21,2	15,0	16,00
19	14,0	20,0	14,0	30,0	21,0	22,40
22	18,8	27,0	18,8	39,4	28,0	30,10
23	21,0	29,5	21,0	44,4	31,5	33,50
26	27,0	38,0	27,0	57,0	40,0	43,00
32	40,0	56,0	40,0	85,0	60,0	64,00

* If a Crosby A-1338 Cradle Grab Hook is used at a minimum angle of choke of 120 degrees, the full sling rated WLL (Single leg) can be utilized.

Table 5
Grade 80 (Spectrum 8®) Alloy Chain Working Load Limit — 4 to 1 Design Factor

Nominal Size of Sling (mm)	Single Leg (t)	Two Leg Slings		Triple and Four-Leg Slings		Choker Hitch (t)*
		0° < β ≤ 45° (t)	45° < β ≤ 60° (t)	0° < β ≤ 45° (t)	45° < β ≤ 60° (t)	
6	1,12	1,60	1,12	2,36	1,70	0,90
7	1,50	2,12	1,50	3,15	2,24	1,20
8	2	2,80	2	4,25	3	1,60
10	3,15	4,25	3,15	6,70	4,75	2,50
13	5,30	7,50	5,30	11,20	8	4,25
16	8	11,20	8	17	11,80	6,40
19-20	11,20	16	11,20	23,60	17	9
22	15	21,20	15	31,50	22,40	12
23	21,20	23,60	16	35,50	25	12,80
26	21,20	30	21,20	45	31,50	17
32	31,50	45	31,50	67	47,50	25,20

* If a Crosby A-1338 Cradle Grab Hook is used at a minimum angle of choke of 120 degrees, the full sling rated WLL (Single leg) can be utilized.



Crosby®

ap·peal \ə-ˈpēl\ n [ME *appel*, fr. AF *apel*, fr. *apeler*]
1: to be especially attractive, pleasing, interesting, or enjoyable: The Crosby Group appeals to me...

The Crosby appeal...

“One of many value added features that helps make Crosby so appealing is our ongoing commitment to utilize the latest technology in order to provide the information required to ensure the proper application of our products.”



Scan our QR Code with your smart device to visit the App Store®



Some of our most popular value added reference guides are now mobile.



Each app tool offers special enhancements and features that are easy to use and user friendly. Check out all the new Crosby apps ready for download at the App Store® today.

APP STORE is a registered trademark of Apple Inc. Application availability and pricing are subject to change. Some features require iOS4 update.

www.thecrosbygroup.com

Alphabetical Index

Assembly Charts

Grade 80	22
Grade 100	8-9

CROSBY® Fittings and Chain

Alloy Chain	10, 21
Chain	10, 21
Chain Shortener Link	13
Chain Sling Information	25-27
Coupler Link	13
Eliminator	12
Grade 80 Alloy Chain	21
Grade 80 Alloy Fittings	22-23
Grade 100 Alloy Chain	10
Grade 100 Alloy Fittings	8-18

Hooks

Grade 80	22
Grade 100	14-18
Chain Choker	18
Clevis Grab	13-14
Clevis Sling	17

Eye Grab	14
Eye Sling	17
Foundry	17
Shank	15
SHUR-LOC®	15-16
Swivel	16

Links

Lok-A-Loy 10 Connecting Links	13
Master Links	11, 23
Reeving Link	18

Product Warnings

Replacement Kits

Sling I.D. Tags

Working Load Limit Charts

Grade 80	21
Grade 100	10

Crosby®

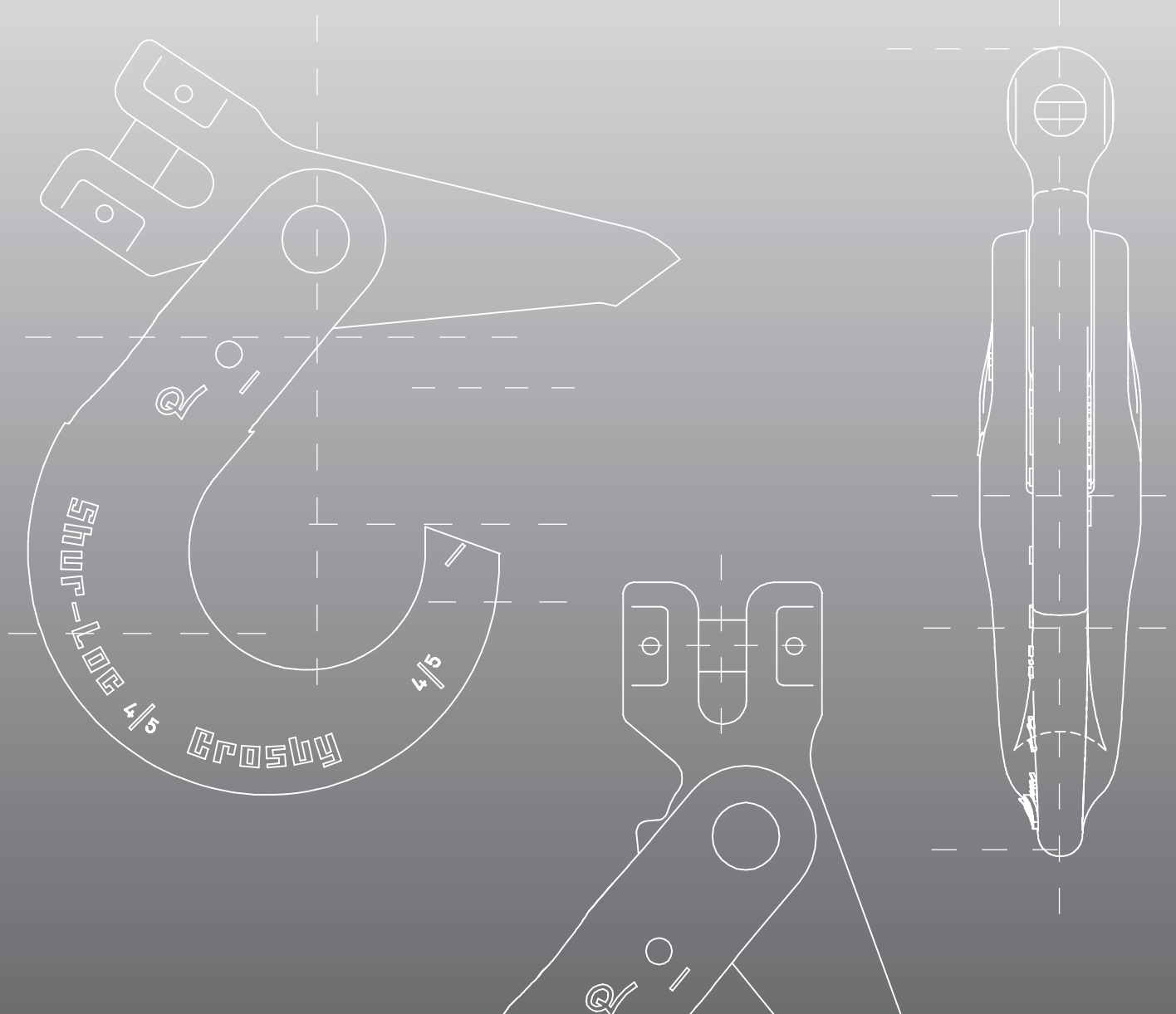

Crosby Products Distributed By:

Crosby Europe:

BELGIUM

Industriepark Zone B N°26
2220 Heist-op-den-Berg
P: (+32) (0)15 75 71 25
F: (+32) (0)15 75 37 64
sales@crosbyeurope.com

FRANCE

21, rue du Petit Albi
Parc d'Affaires Silic
95800 Cergy - St. Christophe
P: (+33) (0)1 34 201 180
F: (+33) (0)1 34 201 188
sales@crosbyeurope.fr

UNITED KINGDOM

Station Street
Cradley Heath
West Midlands B64 6AJ
P: (+44) (0)1226 290 516
F: (+44) (0)1226 240 118
sales@crosbyeurope.co.uk