



# CAS Product Specifications

## COMMERCIAL SPLIT SYSTEMS CONDENSING UNITS R-410A, 6 to 20 TONS

### BUILT TO LAST, EASY TO INSTALL AND SERVICE

- Single stage cooling capacity control on all 072 to 150 models
  - Terminal board facilitating simple safety circuit troubleshooting and simplified control box
  - Outdoor temperature cooling operation range up to 125°F (52°C) and down to 35°F (2°C)
  - All models utilize copper tube / aluminum plate fin coils
  - Brass suction and liquid line service valves
  - Full perimeter base rail with built-in rigging adapters and fork truck slots
  - Pre-painted exterior panels and primer-coated interior panels tested to 500 hours salt spray protection
  - Compressors mounted on independent vibration isolators
  - High capacity filter drier is supplied for each circuit. Field installation is required
  - Comfort Alert™ Diagnostic Board  
LED Go-No-Go and fault code  
Built in time guard anti-short cycle  
3-phase fault protection  
Fault code retention logic  
Low volt compressor contactor protector
  - All units have high and low pressure switches
  - Direct drive permanently lubricated condenser fan motors
  - UL and UL, Canada apply to standard units; 575 volt units UL, Canada only
- LIMITED WARRANTY**
- 5 Year compressor limited warranty
  - 1 Year parts limited warranty



CAS072-121



CAS240



Use of the AHR Certified TM Mark indicates a manufacturer's participation in the program. For verification of certification for individual products, go to [www.ahrirectory.org](http://www.ahrirectory.org).



UNIT PERFORMANCE DATA <sup>1</sup> – Single Circuit						
Model Number	COOLING			Total Power (KW)	Unit Dimensions H x W x L Inches [mm]	Ship Weight lb. / kg
	Nominal Capacity Ton	Net Capacity BTUH	E.E.R			
CAS072*AA0A00A	6	71,000	11.5	6.2	42-3/8 x 59-3/8 x 45-7/8 [1077 x 1508 x 1164]	389 / 176
CAS091*AA0A00A	7.5	92,000	11.2	8.2	42-3/8 x 59-3/8 x 45-7/8 [1077 x 1508 x 1164]	391 / 177
CAS121*AA0A00A	10	117,000	11.2	10.4	50-3/8 x 59-3/8 x 45-7/8 [1279 x 1507 x 1164]	490 / 222
CAS151*AA0A00A	12.5	148,000	11.0	13.5	50-3/8 x 59-3/8 x 45-7/8 [1279 x 1507 x 1164]	598 / 271
CAS181*AA0A00A	15	184,000	11.2	16.4	50-3/8 x 86-3/8 x 45-1/8 [1279 x 2193 x 1148]	731 / 322
CAS241*AA0A00A	20	240,000	11.0	21.8	50-3/8 x 86-3/8 x 67-1/8 [1279 x 2193 x 1704]	978 / 444
UNIT PERFORMANCE DATA <sup>1</sup> – Dual Circuit						
CAS120*DA0A00A	10	117,000	11.2	10.4	50-3/8 x 59-3/8 x 45-7/8 [1279 x 1507 x 1164]	516 / 234
CAS150*DA0A00A	12.5	148,000	11.0	13.5	50-3/8 x 59-3/8 x 45-7/8 [1279 x 1507 x 1164]	654 / 297
CAS180*DA0A00A	15	184,000	11.2	16.4	50-3/8 x 86-3/8 x 45-1/8 [1279 x 2193 x 1148]	731 / 322
CAS240*DA0A00A	20	240,000	11.0	21.8	50-3/8 x 86-3/8 x 67-1/8 [1279 x 2193 x 1704]	978 / 444

\* – Indicates Unit voltage: H = 208/230-3-60, L = 460-3-60, S = 575-3-60

<sup>1</sup> – Above ratings are with matching size air handling unit

# MODEL NUMBER NOMENCLATURE

MODEL SERIES	C	A	S	0	9	1	H	A	A	0	A	0	0	A
Position Number	1	2	3	4	5	6	7	8	9	10	11	12	13	14
C = R-410A Condensing Unit														
A = Air Conditioning (Cooling Only)														
H = Heat Pump														
<b>Type</b>														
S = Standard ASHRAE 90.1-2010 Efficiency														
<b>Efficiency</b>														
072 = 71,000 BTUH = 6 Tons														
091 = 92,000 BTUH = 7.5 Tons (1 circuit)														
120 = 117,000 BTUH = 10 Tons (2 circuit)														
121 = 117,000 BTUH = 10 Tons (1 circuit)														
150 = 148,000 BTUH = 12.5 Tons (2 circuit)														
151 = 148,000 BTUH = 12.5 Tons (1 circuit)														
180 = 180,000 BTUH = 15 Tons (2 circuit)														
181 = 180,000 BTUH = 15 Tons (1 circuit)														
240 = 240,000 BTUH = 20 Tons (2 circuit)														
241 = 240,000 BTUH = 20 Tons (1 circuit)														
<b>Nominal Cooling Capacity</b>														
H = 208/230-3-60														
L = 460-3-60														
S = 575-3-60														
<b>Voltage</b>														
A = Single Circuit														
B = Single Circuit w/ Low Ambient Control														
D = Dual Circuit														
E = Dual Circuit w/ Low Ambient Control														
G = Single Circuit 2 Stage (072 & 091 models only)														
H = Single Circuit 2 Stage w/ Low Ambient Control (072 & 091 models only)														
<b>Refrigerant System Options</b>														
A = Cu/Al Cond. RTPF														
B = Precoat Al/Cu Cond. RTPF														
C = E-Coat Al/Cu Cond. RTPF														
E = Cu/Cu Cond. RTPF														
<b>Outdoor Coil Options</b>														
0 = None														
1 = Non-powered 115v Convenience Outlet														
<b>Service Options</b>														
A = None														
C = Non-Fused Disconnect Switch														
<b>Electrical Options</b>														
0 = Standard Elec-Mechanical Control														
<b>Base Unit Controls</b>														
0 = No options, reserved for future Use														
<b>Future Use</b>														
A = Original Design														
<b>Sales Digit</b>														



Use of the AHRI Certified TM Mark indicates a manufacturer's participation in the program. For verification of certification for individual products, go to [www.ahridirectory.org](http://www.ahridirectory.org).



CAS - 6 to 12.5 Ton  
CAS - 10 to 12.5 Ton



CAS - 15 to 20 Ton



Certified to ISO 9001

## AHRI\* CAPACITY RATINGS

UNIT	COOLING STAGES	COMPRESSORS	NOM. CAPACITY (TONS)	NET COOLING CAPACITY (MBH)	TOTAL POWER (kW)	EER	IEER	IEER w/ 2-SPEED
CAS072(A,B)/FAS072	1	1	6	71.0	6.2	11.5	12.2	N/A
CAS091(A,B)/FAS091	1	1	7.5	92.0	8.2	11.2	11.8	N/A
CAS121(A,B)/FAS120	1	1	10	117.0	10.4	11.2	12.0	N/A
CAS151(A,B)/FAS150	1	1	12.5	148.0	13.5	11.0	12.0	N/A
CAS181(A,B)/FAS180	1*	2	15	184.0	16.4	11.2	13.2	14.3
CAS241(A,B)/FAS240	1*	2	20	240.0	21.8	11.0	12.5	13.6

\* Single circuit with two (tandem) compressors.

UNIT	COOLING STAGES	COMPRESSORS	NOM. CAPACITY (TONS)	NET COOLING CAPACITY (MBH)	TOTAL POWER (kW)	EER	IEER	IEER w/ 2-SPEED
CAS072(G,H)/FAS072	2	1	6	70.0	5.8	12.0	12.2	14.0
CAS091(G,H)/FAS091	2	1	7.5	92.0	8.2	11.2	11.8	12.9
CAS120(G,H)/FAS120	2	2	10	117.0	10.4	11.2	11.6	13.0
CAS150(G,H)/FAS150	2	2	12.5	148.0	13.5	11.0	12.0	12.5
CAS180(G,H)/FAS180	2	2	15	184.0	16.4	11.2	11.8	12.6
CAS240(G,H)/FAS240	2	2	20	240.0	21.8	11.0	11.2	12.0

### LEGEND

- AHRI – Air Conditioning, Heating and Refrigeration Institute  
 ASHRAE – American Society of Heating, Refrigerating and Air Conditioning, Inc.  
 EER – Energy Efficiency Ratio  
 IEER – Integrated Energy Efficiency Ratio

### NOTES

- Rated in accordance with AHRI Standard 340/360, as appropriate.
- Ratings are based on:  
**Cooling Standard:** 80°F (27°C) db, 67°F (19°C) wb indoor air temp and 95°F (35°C) db outdoor air temp.  
**IEER Standard:** 80°F (27°C) db, 67°F (19°C) wb indoor air temp and 4 various outdoor temperatures.
- All units comply with ASHRAE 90.1 Energy Standard for minimum EER and IEER requirements.

## SOUND POWER LEVELS, dB

UNIT	COOLING CIRCUITS	OUTDOOR SOUND (dB)								
		A-WEIGHTED	63	125	250	500	1000	2000	4000	8000
<b>RTPF – Round Tube/Plate Fin Coil Design</b>										
CAS072	1 & 2	85	89.3	85.0	82.0	82.7	80.2	75.2	71.0	66.0
CAS091	1 & 2	85	89.3	85.0	82.0	82.7	80.2	75.2	71.0	66.0
CAS121	1	83	86.6	81.9	85.7	80.0	77.1	74.6	69.2	65.8
CAS120	2	84	86.3	85.8	81.4	81.9	79.5	75.1	71.9	68.9
CAS151	1	84	89.1	85.7	83.0	81.1	79.3	74.9	69.7	62.2
CAS150	2	83	81.7	80.9	82.2	80.4	78.2	73.6	69.7	65.4
CAS181	1	83	86.7	81.2	78.9	80.4	78.0	74.2	70.2	65.0
CAS180	2	83	86.7	81.2	78.9	80.4	78.0	74.2	70.2	65.0
CAS241	1	85	91.0	85.0	80.0	86.0	79.0	73.0	68.0	63.0
CAS240	2	85	91.0	85.0	80.0	86.0	79.0	73.0	68.0	63.0

### LEGEND

dB = Decibel

**NOTE:** Outdoor sound data is measure in accordance with AHRI standard 270.

# PHYSICAL DATA

Single Circuit Models with RTPF – Round Tube/Plate Fin Coil Design								
	CAS072 (A,B)	CAS072 (G,H)	CAS091 (A,B)	CAS091 (G,H)	CAS121	CAS151	CAS181	CAS241
<b>Refrigeration System</b>								
# Circuits / # Comp. / Type	1 / 1 / Scroll	1 / 1 / 2 Stage Scroll	1 / 1 / Scroll	1 / 1 / Digital Scroll	1 / 1 / Scroll	1 / 1 / Scroll	1 / 2 / Scroll	1 / 2 / Scroll
R-410a charge A/B (lbs)	9.0	9.0	9.0	9.0	9.0	9.0	9.0	9.0
System charge w/ fan coil*	14.0	14.0	17.0	18.0	20.0	43.0	43.0	38.0
Metering device	TXV	TXV	TXV	TXV	TXV	TXV	TXV	TXV
High–press. Trip / Reset (psig)	630 / 505	630 / 505	630 / 505	630 / 505	630 / 505	630 / 505	630 / 505	630 / 505
Low–press. Trip / Reset (psig)	54 / 117	54 / 117	54 / 117	54 / 117	54 / 117	54 / 117	54 / 117	54 / 117
<b>Cond. Coil</b>								
Material (Fin/Tube)	Al/Cu	Al/Cu	Al/Cu	Al/Cu	Al/Cu	Al/Cu	Al/Cu	Al/Cu
Coil type	RTPF	RTPF	RTPF	RTPF	RTPF	RTPF	RTPF	RTPF
Rows / FPI	2 / 17	2 / 17	2 / 17	2 / 17	2 / 17	3 / 17	2 / 17	2 / 17
Total face area (ft2)	17.5	17.5	17.5	23.0	25.1	31.8	23.5 x 2	25.0 x 2
<b>Cond. fan / motor</b>								
Qty / Motor drive type	2 / direct	2 / direct	2 / direct	2 / direct	2 / direct	2 / direct	3 / direct	4 / direct
Motor HP / RPM	1/4 / 1100	1/4 / 1100	1/4 / 1100	1/4 / 1100	1/4 / 1100	1/4 / 1100	1/4 / 1100	1/4 / 1100
Fan diameter (in)	22	22	22	22	22	22	22	22
Nominal Airflow (cfm)	6,000	6,000	6,000	6,000	6,000	6,000	9,000	12,000
Watts (total)	610	610	610	610	610	610	970	1150

\* Approximate system charge with about 25 ft piping of sizes indicated with matched FAS

Dual Circuit Models with RTPF – Round Tube/Plate Fin Coil Design				
	CAS120 (D,E)	CAS150 (D,E)	CAS180 (D,E)	CAS240 (D,E)
<b>Refrigeration System</b>				
# Circuits / # Comp. / Type	2 / 2 / Scroll	2 / 2 / Scroll	2 / 2 / Scroll	2 / 2 / Scroll
R-410a charge A/B (lbs)	9.0 / 9.0	9.0 / 9.0	9.0 / 9.0	9.0 / 9.0
System charge w/ fan coil*	11.0 / 11.0	22.0 / 22.0	22.0 / 22.0	19.0 / 19.0
Metering device	TXV	TXV	TXV	TXV
High–press. Trip / Reset (psig)	630 / 505	630 / 505	630 / 505	630 / 505
Low–press. Trip / Reset (psig)	54 / 117	54 / 117	54 / 117	54 / 117
<b>Cond. Coil</b>				
Material (Fin/Tube)	Al/Cu	Al/Cu	Al/Cu	Al/Cu
Coil type	RTPF	RTPF	RTPF	RTPF
Rows / FPI	2 / 17	3 / 17	2 / 17	2 / 17
total face area (ft2)	25.1	31.8	23.5 x 2	25.0 x 2
<b>Cond. fan / motor</b>				
Qty / Motor drive type	2 / direct	2 / direct	3 / direct	4 / direct
Motor HP / RPM	1/4 / 1100	1/4 / 1100	1/4 / 1100	1/4 / 1100
Fan diameter (in)	22	22	22	22
Nominal Airflow (cfm)	6,000	6,000	9,000	12,000
Watts (total)	610	610	970	1150

\* Approximate system charge with about 25 ft piping of sizes indicated with matched FAS

# DIMENSIONS

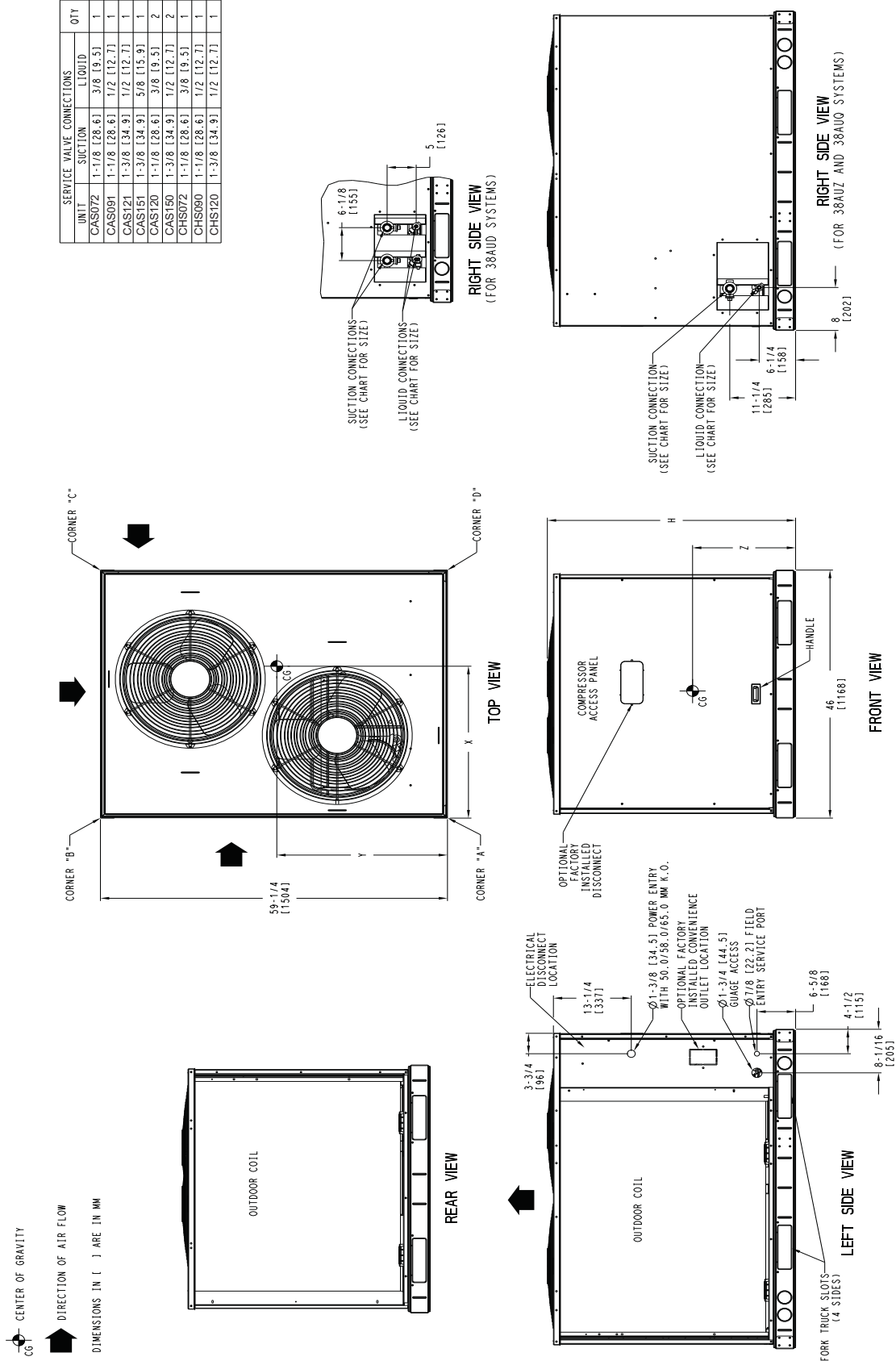

# DIMENSIONS (cont.)

UNIT	ELECTRICAL CHARACTERISTICS	STD. UNIT WT.		CORNER A		CORNER B		CORNER C		CORNER D		CENTER OF GRAVITY			UNIT HEIGHT H			
		LBS.	KG.	LBS.	KG.	LBS.	KG.	LBS.	KG.	LBS.	KG.	X	Y	Z				
CAS072	208/230-3-60,460-3-60,575-3-60	389	176	141	64	96	44	62	28	91	41	18	[457.2]	24	[609.6]	21	[533.4]	42-3/8 [1076.0]
CAS091 (A/B)	208/230-3-60,460-3-60,575-3-60	391	177	142	64	96	44	62	28	91	41	18	[457.2]	24	[609.6]	21	[533.4]	42-3/8 [1076.0]
CAS091 (D/E)	208/230-3-60,460-3-60,575-3-60	430	195	142	64	96	44	76	34	111	50	18	[457.2]	24	[609.6]	21	[533.4]	42-3/8 [1076.0]
CAS121	208/230-3-60,460-3-60,575-3-60	490	222	177	80	120	54	78	35	114	52	18	[457.2]	24	[609.6]	24	[609.6]	50-3/8 [1279.2]
CAS151	208/230-3-60,460-3-60,575-3-60	598	271	195	88	142	64	110	50	151	68	20	[508.0]	25	[635.0]	24	[609.6]	50-3/8 [1279.2]
CAS120	208/230-3-60,460-3-60,575-3-60	516	234	185	84	117	53	83	38	131	59	19	[482.6]	23	[584.2]	24	[609.6]	50-3/8 [1279.2]
CAS150	208/230-3-60,460-3-60,575-3-60	654	297	214	97	155	70	120	54	165	75	20	[508.0]	25	[635.0]	24	[609.6]	50-3/8 [1279.2]
CHS072	208/230-3-60,460-3-60,575-3-60	444	201	134	61	97	44	90	41	123	56	22	[558.8]	25	[635.0]	13	[330.2]	42-3/8 [1076.0]
CHS090 (A/B)	208/230-3-60,460-3-60,575-3-60	483	219	162	74	110	50	85	39	125	57	20	[508.0]	24	[609.6]	21	[533.4]	42-3/8 [1076.0]
CHS090 (D/E)	208/230-3-60,460-3-60,575-3-60	523	237	174	79	118	54	96	44	135	61	21	[533.4]	24	[609.6]	23	[584.2]	50-3/8 [1279.2]
CHS120	208/230-3-60,460-3-60,575-3-60	575	261	186	84	126	57	106	48	157	71	21	[533.4]	24	[609.6]	23	[584.2]	50-3/8 [1279.2]

**NOTES:**

1. MINIMUM CLEARANCE (LOCAL CODES OR JURISDICTION MAY PREVAIL):
  - A. BOTTOM TO COMBUSTIBLE SURFACES: 0 INCHES.
  - B. OUTDOOR COIL, FOR PROPER AIR FLOW: 36 INCHES ONE SIDE, 12 INCHES THE OTHER. THE SIDE GETTING THE GREATER CLEARANCE IS OPTIONAL. STANDARD CLEARANCES ON REMAINING TWO SIDES.
  - C. OVERHEAD: 60 INCHES, TO ASSURE PROPER OUTDOOR FAN OPERATION.
  - D. BETWEEN UNITS: CONTROL BOX SIDE, 42 INCHES PER NEC.
  - E. BETWEEN UNIT AND UNGROUNDED SURFACES: CONTROL BOX SIDE, 36 INCHES PER NEC.
  - F. BETWEEN UNIT AND BLOCK OR CONCRETE WALLS AND OTHER GROUNDED SURFACES: CONTROL BOX SIDE, 42 INCHES PER NEC.
2. WITH EXCEPTION OF THE CLEARANCE FOR THE OUTDOOR COIL AS STATED IN NOTE 1B, A REMOVABLE FENCE OR BARRICADE REQUIRES NO CLEARANCE.
3. UNITS MAY BE INSTALLED ON COMBUSTIBLE FLOORS MADE FROM WOOD OR CLASS A, B OR C ROOF COVERING MATERIAL.

# DIMENSIONS (cont.)

- NOTES:**
- MINIMUM CLEARANCE (LOCAL CODES OR JURISDICTION MAY VARY):
    - A. BOTTOM TO COMBUSTIBLE SURFACES: 0 INCHES.
    - B. OUTDOOR COIL FOR PROPER AIR FLOW: 36 INCHES ONE SIDE, 12 INCHES THE OTHER. THE SIDE GETTING THE GREATER CLEARANCE IS OPTIONAL.
    - C. OVERHEAD: 60 INCHES, TO ASSURE PROPER OUTDOOR FAN OPERATION.
    - D. BETWEEN UNIT AND UNGROUND SURFACES: CONTROL BOX SIDE: 36 INCHES PER NEC.
    - E. BETWEEN UNIT AND UNGROUND SURFACES: CONTROL BOX SIDE: 36 INCHES PER NEC.
    - F. BETWEEN UNIT AND BLOCK OR CONCRETE WALLS AND OTHER GROUNDED SURFACES: CONTROL BOX SIDE, 42 INCHES PER NEC.
  - WITH EXCEPTION OF THE CLEARANCE FOR THE OUTDOOR COIL AS STATED IN NOTE 1B, A REMOVABLE FENCE OR SHIELD REQUIRES NO CLEARANCE.
  - THIS UNIT IS FIELD ASSEMBLED. REMOVABLE FLOORS MADE FROM WOOD OR CLASS A, B OR C ROOF COVERING MATERIAL.

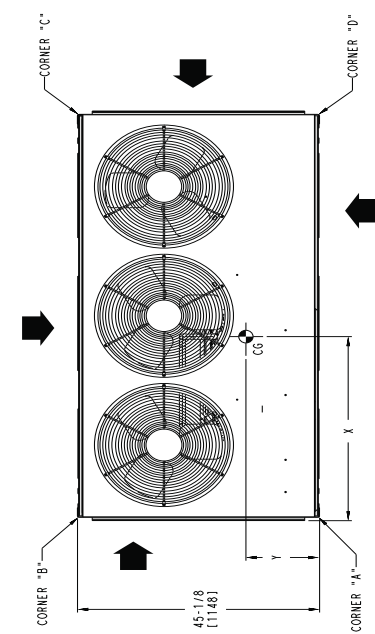

**TOP VIEW**

UNIT	ELECTRICAL CHARACTERISTICS			STD. UNIT WT.			CORNER A			CORNER B			CORNER C			CORNER D			CENTER OF GRAVITY			UNIT HEIGHT						
	LBS.			K.G.			LBS.			K.G.			LBS.			K.G.			X			Y			H			
CAS181	208	230	3-60	460	3-60	575	3-60	731	332	237	107	1172	78	135	61	186	84	38	1965	21	19	1482	61	17	[431.8]	150	378	[1219.2]
CAS180	208	230	3-60	460	3-60	575	3-60	731	332	237	107	1172	78	135	61	186	84	38	1965	21	19	1482	61	17	[431.8]	150	378	[1219.2]

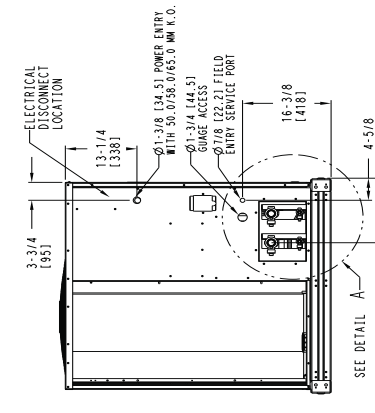

**LEFT SIDE VIEW FOR 38AOLD SYSTEMS**

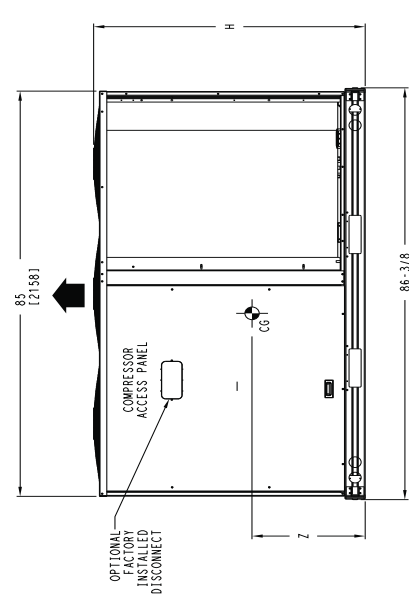

**FRONT VIEW**

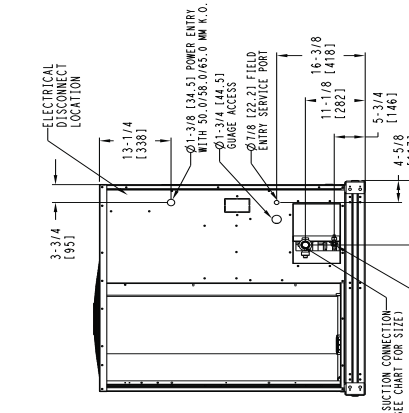

**LEFT SIDE VIEW**

UNIT	SERVICE VALVE CONNECTIONS		QTY
	SUCTON	LIQUID	
CAS181	1-3/8 [34.9]	5/8 [15.9]	1 EA
CAS180	1-3/8 [34.9]	1/2 [12.7]	2 EA

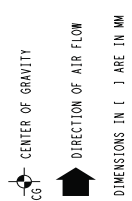

DIMENSIONS IN ( ) ARE IN MM

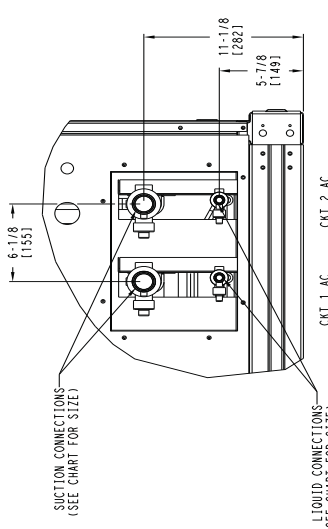

**DETAIL A**  
(NOTE POSITION OF CKT 1)

# DIMENSIONS (cont.)

UNIT	ELECTRICAL CHARACTERISTICS		STD. UNIT WT.				CORNER A				CORNER B				CORNER C				CORNER D				CENTER OF GRAVITY				UNIT HEIGHT			
	LBS.	KG.	LBS.	KG.	LBS.	KG.	LBS.	KG.	LBS.	KG.	LBS.	KG.	LBS.	KG.	LBS.	KG.	LBS.	KG.	LBS.	KG.	X	Y	Z	H	LBS.	KG.	LBS.	KG.	LBS.	KG.
CAS241	208/230-3-60	460-3-60	515-3-60	978	444	360	163	188	85	147	67	283	128	38	1965.2	23	1584.2	21	11	[431.8]	17	[431.8]	150-3/8	[1219.2]						
CAS240	208/230-3-60	460-3-60	515-3-60	978	444	360	163	188	85	147	67	283	128	38	1965.2	23	1584.2	21	11	[431.8]	17	[431.8]	150-3/8	[1219.2]						

- NOTES:
- MINIMUM CLEARANCE (LOCAL CODES OR JURISDICTION MAY APPLY):
    - A. BOTTOM TO COMBUSTIBLE SURFACES: 0 INCHES
    - B. OUTDOOR COIL FOR PROPER AIR FLOW: 36 INCHES ONE SIDE, 12 INCHES THE OTHER, THE SIDE GETTING THE GREATER CLEARANCE IS OPTIONAL.
    - C. OVERHEAD: 60 INCHES, TO ASSURE PROPER OUTDOOR FAN CLEARANCE.
    - D. BETWEEN UNITS: CONTROL BOX SIDE, 42 INCHES PER NEC.
    - E. BETWEEN UNIT AND UNGROUNDED SURFACES: CONTROL BOX SIDE, 36 INCHES PER NEC.
    - F. BETWEEN UNIT AND BLOCK OR CONCRETE WALLS AND OTHER GROUNDED SURFACES: CONTROL BOX SIDE, 42 INCHES PER NEC.
  - WITH EXCESSIVE CLEARANCE OF THE OUTDOOR COIL OR BARRICADE REQUIRES NO CLEARANCE.
  - UNITS MAY BE INSTALLED ON COMBUSTIBLE FLOORS MADE FROM WOOD OR CLASS A, B OR C ROOF COVERING MATERIAL.

SERVICE VALVE CONNECTIONS			
UNIT	SUCTION	LIQUID	QTY
CAS241	1-5/8 [41.3]	5/8 [15.9]	1 EA
CAS240	1-3/8 [34.9]	1/2 [12.7]	2 EA

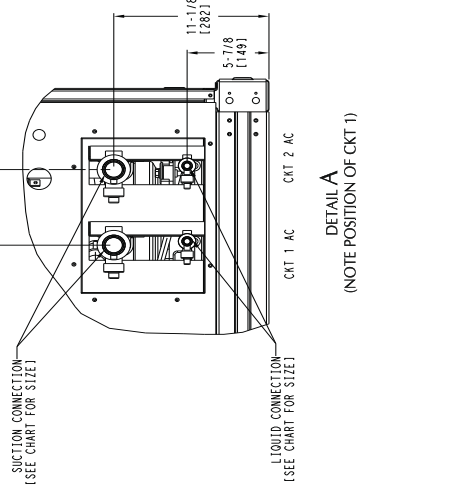
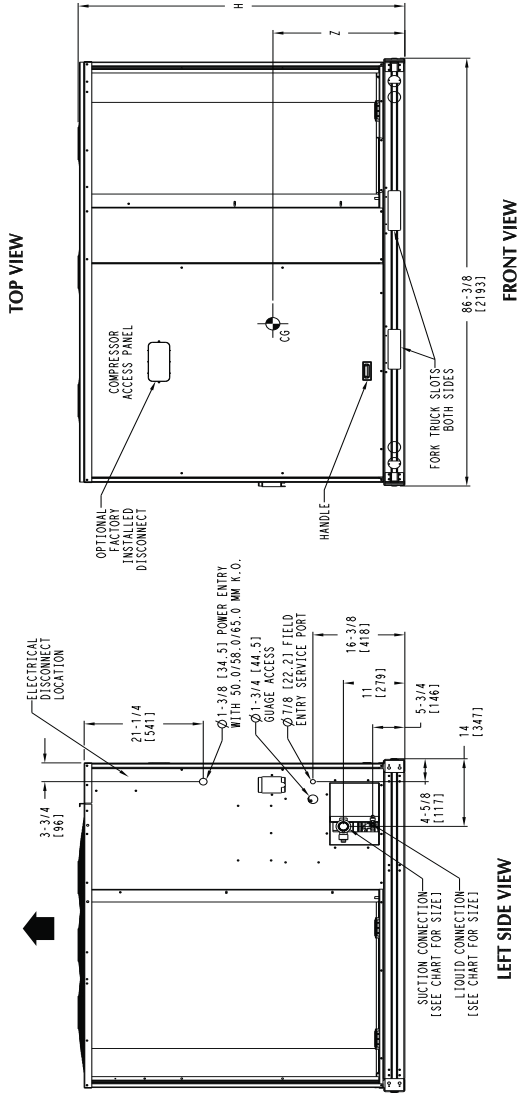
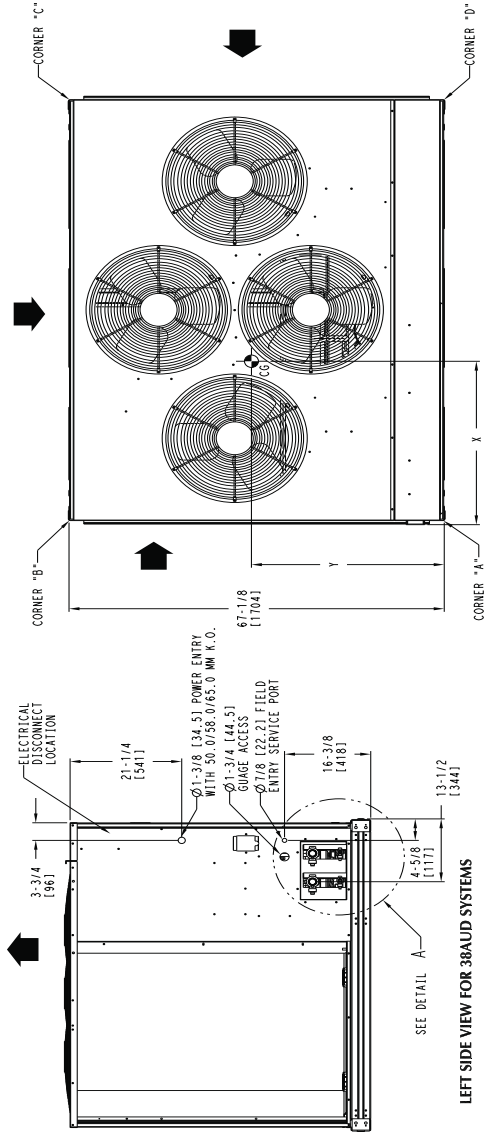
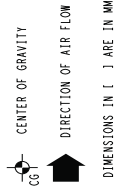



# OPTIONS AND ACCESSORIES

## CAS OPTIONS AND ACCESSORIES

ITEM	OPTION*	ACCESSORY†
Disconnect Switch (non-fused)‡	X	
Special-coated Coil Protection	X	
Convenience Outlet (115-v)**	X	
Low Ambient Temperature MotorMaster I® Control	X	X
Louvered Hail Guard		X
Programmable Thermostats		X

\* Factory-installed option.

† Field-installed accessory.

‡ Non-fused disconnect switch cannot be used when unit MOCP electrical rating exceeds 80 amps.

\*\* Non-powered versions available

## CAS factory-installed options

### CONDENSER COIL OPTIONS

#### Coil Coating Application – Round Tube/Plate Fin Coils

Description	Environment					
	Standard Non-Corrosive	Mild Coastal	Moderate Coastal	Severe Coastal	Industrial	Industrial & Coastal
Alum Fin / Cu Tube	X					
Pre-Coated Al / Cu		X				
E-Coated Al / Cu					X	X
Cu / Cu			X	X		

**NOTE:** Refer to the Guide Specifications for further detail.

**E-coated aluminum-fin coils** have a flexible and durable epoxy coating uniformly applied to all coil surfaces. Unlike brittle phenolic dip and bake coatings, E-coating provides superior protection with unmatched flexibility, edge coverage, metal adhesion, thermal performance, and most importantly, corrosion resistance.

**E-coated coils** provide this protection since all coil surfaces are completely encapsulated from environmental contamination. This coating is especially suitable in industrial environments.

**Pre-coated coils** (RTPF coils only) provide protection in mild coastal environments.

**-20°F (-29°C) low-ambient temperature kit option (MotorMaster I®)** controls outdoor-fan motor operation to maintain the correct head pressure at low outdoor ambient temperatures.

**Louvered hail guard package** protects coils against damage from flying debris and hail.

**115-v convenience outlet** is used to power electric drills, lights, and refrigerant recovery machines. This means that a separate 115-v power supply is no longer necessary.

**Non-fused disconnect switch** is used to remove power locally at the condensing unit. This switch also includes a power lockout capability to protect the service person. This lockout switch saves the service person time and effort because there is no need to access a distant disconnect switch while servicing the unit.

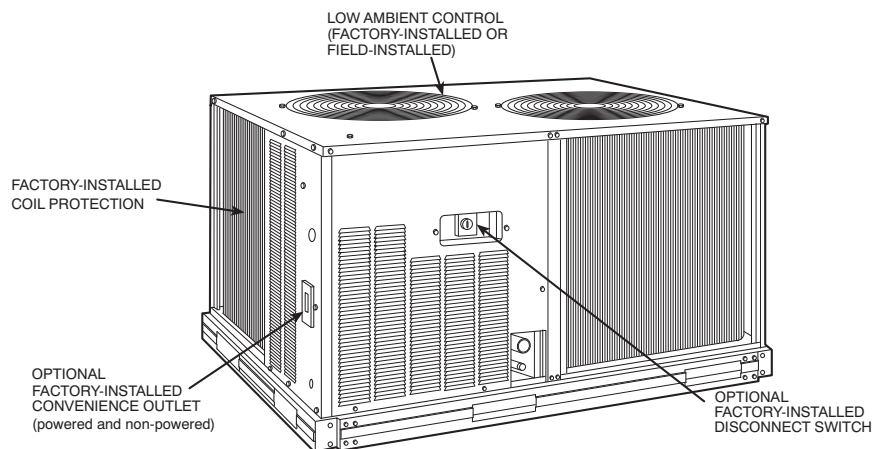

C101216

## OPTIONS AND ACCESSORIES (cont.)

### CAS field-installed accessories

**-20°F (-29°C) low-ambient temperature kit accessory (MotorMaster I®)** controls outdoor-fan motor operation to maintain the correct head pressure at low outdoor ambient temperatures.

**Louvered hail guard package** protects coils against damage from flying debris and hail.

**Condenser coil grille** package protects condensing unit coil from impact by large objects and vandalism.

### FAS OPTIONS AND ACCESSORIES

ITEM	OPTION*	ACCESSORY†
Alternate Fan Motors	X	
Alternate Drives	X	
CO <sub>2</sub> Sensors		X
Condensate Drain Trap		X
Discharge Plenum		X
Economizer		X
Electric Heat		X
Overhead Suspension Package		X
Prepainted Units	X	
Return Air Grille		X
Steam Heating Coil		X
Subbase		X

\* Factory-installed option.

† Field-installed accessory.

### FAS factory-installed options

**Alternate fan motors and drives** are available to provide the widest possible range of performance.

**Units constructed of prepainted steel** are available from the factory for applications that require painted units. Unit color is American Sterling Gray.

### FAS field-installed accessories

**One-row steam coil** has 1-in. OD copper tube and aluminum fins. The Inner Distributing Tube (IDT) design provides uniform temperatures across the coil face. The IDT steam coils are especially suited to applications where sub-freezing air enters the unit.

**Electric resistance heat coils** have an open-wire design and are mounted in a rigid frame. Safety cutouts for high temperature conditions are standard.

**Economizer (enthalpy controlled)** provides ventilation air and provides “free” cooling if the outside ambient temperature and humidity are suitable. The economizer can be used in both vertical and horizontal positions.

**Discharge plenum** directs the air discharge into the occupied space; integral horizontal and vertical louvers enable redirection of airflow. This accessory is available unpainted or painted.

**Return-air grille** provides a protective barrier over the return-air opening and gives a finished appearance to units installed in the occupied space. This accessory is available unpainted or painted.

**Subbase** provides a stable, raised platform and room for condensate drain connection for floor-mounted units. This accessory is available unpainted or painted.

**Overhead suspension package** includes necessary brackets to support units in horizontal installations.

**CO<sub>2</sub> sensors** can be used in conjunction with the economizer accessory to help meet indoor air quality requirements. The sensor signals the economizer to open when the CO<sub>2</sub> level in the space exceeds the setpoint. A programmable thermostat can also be used to override the sensor if the outside-air temperature is too high or too low.

**Condensate drain trap** includes an overflow shutoff switch that can be wired to turn off the unit if the trap becomes plugged. The kit also includes a wire harness that can be connected to an alarm if desired. The transparent trap is designed for easy service and maintenance.

## OPTIONS AND ACCESSORIES (cont.)

ACCESSORIES			
<b>LOW AMBIENT CONTROLS</b>			
PART NUMBER	DESCRIPTION	VOLTAGE	USED ON
CALOWAMB030A00	Motormaster I Combination Kit enables cooling operation down to -20F. Includes: Solid-State Variable Speed Motor Controller, Outdoor Motor, Bracket, Instructions, Wire Ties and time delay relay for timed bypass of low pressure switch on startup.	208/230-3-60	072,091,121, 151 (A,G)
CALOWAMB034A00		208/230-3-60	120, 150 (A,G)
CALOWAMB031A00		460-3-60	072, 091 (A,G)
CALOWAMB032A00		460-3-60	121, 151 (A,G)
CALOWAMB035A00		460-3-60	120, 150 (A,G)
CALOWAMB033A00		575-3-60	072, 091,121,151 (A,G)
CALOWAMB037A00		208/230-3-60	181 (A,G)
CALOWAMB038A00		460-3-60	181 (A,G)
CALOWAMB039A00		575-3-60	181 (A,G)
CALOWAMB018A00		208/230-3-60	241 (A,G)
CALOWAMB019A00		460-3-60	241 (A,G)
CALOWAMB020A00		575-3-60	241 (A,G)
CALOWAMB036A00		575-3-60	120, 150 (D)
CALOWAMB040A00		208/230-3-60	180 (D)
CALOWAMB041A00		460-3-60	180 (D)
CALOWAMB042A00		575-3-60	180 (D)
CALOWAMB021A00		208/230-3-60	240 (D)
CALOWAMB022A00		460-3-60	240 (D)
CALOWAMB023A00		575-3-60	240 (D)
<b>LIQUID LINE SOLENOID VALVE (LLSV) †</b>			
PART NUMBER	DESCRIPTION	USED ON	
1179871/EF680033	Liquid Line Solenoid Valve	Units Requiring (3/8 in) Liquid Lines	
1179872/EF680035	Liquid Line Solenoid Valve	Units Requiring (1/2 in) Liquid Lines	
1179873/EF680036	Liquid Line Solenoid Valve	Units Requiring (5/8 in) Liquid Lines	
1183150/EF680037	Liquid Line Solenoid Valve Coil	All LLSVs listed	
- Contact Application Engineering for refrigerant line lengths greater than 100 ft.			
† LLSV must be installed at the INDOOR unit.			
L - Liquid Line			
<b>SIGHT GLASSES</b>			
PART NUMBER	DESCRIPTION	USED ON	
1179879/KM680008	Sight Glass	Units Requiring (3/8 in.) Liquid Lines	
1179877/KM680004	Sight Glass	Units Requiring (1/2 in.) Liquid Lines	
1179878/KM680005	Sight Glass	Units Requiring (5/8 in.) Liquid Lines	
<b>LOUVERED HAIL GUARDS</b>			
PART NUMBER	DESCRIPTION	APPLICATION USAGE	
CALVHLGD005A00	Louvered Condenser Coil Hail Guard -- Includes louvered panel(s) to protect condenser coil from damage and vandalism	All 072 and 091 (A,B)	
CALVHLGD006A00		091 (G,H)	
CALVHLGD011A00		120, 121	
CALVHLGD012A00		150, 151	
CALVHLGD008A00		180, 181	
CALVHLGD009A00		240, 241	

# OPTIONS AND ACCESSORIES (cont.)

## FAS WITH DISCHARGE PLENUM RETURN-AIR GRILLE AND SUBBASE

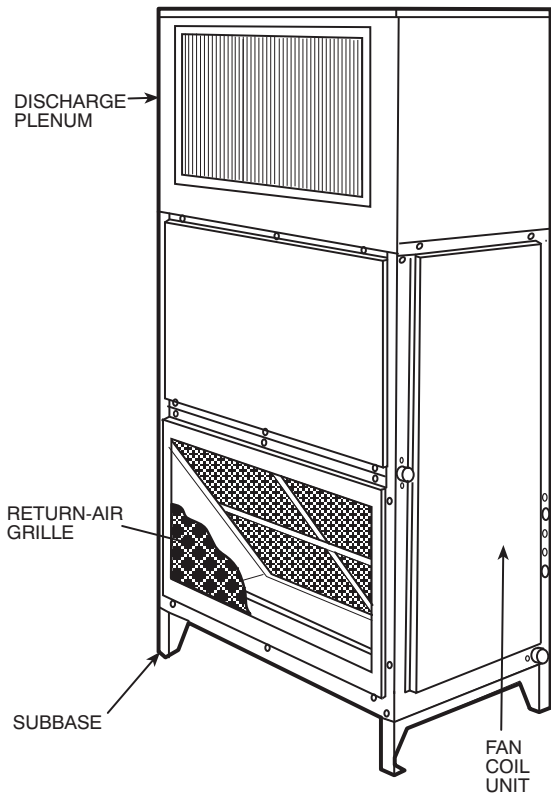

C150211

## FAS WITH CONDENSATE

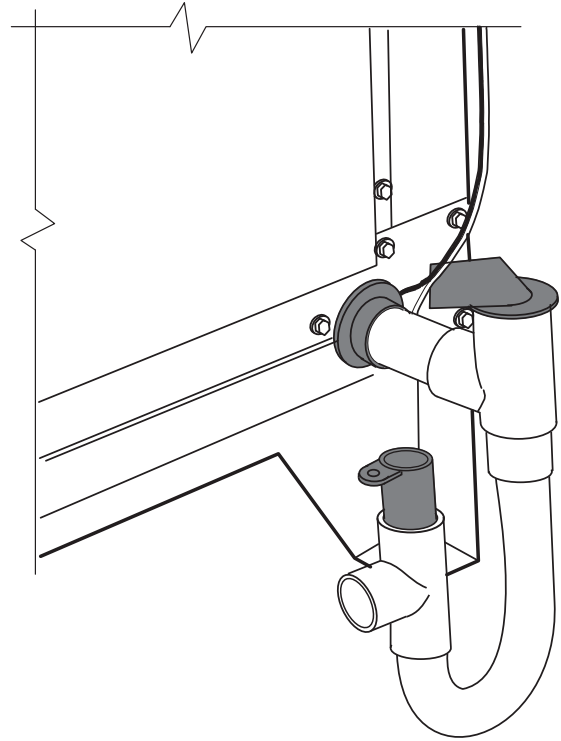

C150218

## FAS WITH ECONOMIZER

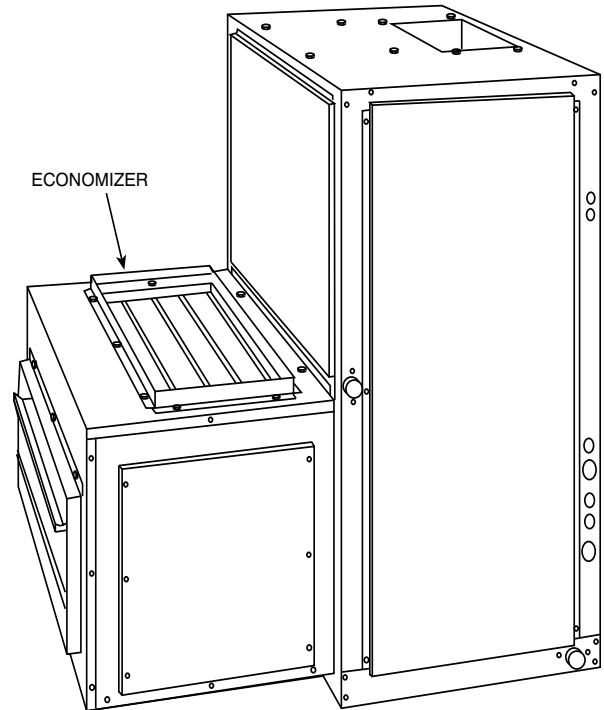

C160002

# SELECTION PROCEDURE

Combination ratings for CAS units matched with FAS Series air handlers are in this book. If unit is used with an air handler, use the ESP selection program to obtain combined ratings.

## I. Determine cooling load, evaporator-air temperature, and quantity.

Given:

Total Cooling Capacity	
Required (TC) .....	121,000 Btuh
Sensible Heat Capacity	
Required (SHC) .....	95,000 Btuh
Compressor Type .....	Scroll
Temperature Air Entering	
Condenser (Edb) .....	95°F
Temperature Air Entering	
Evaporator (db/wb) .....	80°F db, 67°F wb
Evaporator Air Quantity .....	4,000 cfm
External Static Pressure .....	0.4 in. wg
Length of Interconnecting	
Refrigerant Piping .....	25 ft (Linear)
Power Supply (V-Ph-Hz) .....	208/230-3-60

## II. Select condensing unit air-handler combination.

For this example, select a CAS121 matched with a FAS120 coil. This CAS121/FAS120 condensing unit air-handler combination provides 122,000 Btuh of total cooling capacity and 97,200 Btuh of sensible capacity at the given conditions. If other temperatures or airflow values are required, interpolate the values from the combination ratings.

## III. Determine sizes of liquid and suction lines.

Enter Refrigerant Piping Sizes table. The sizes shown are based on an equivalent length of pipe. This equivalent length is equal to the linear length of pipe indicated at the top of each sizing column, plus a 50% allowance for fitting losses. For this example, note in the linear length column that the proper pipe size is  $1\frac{1}{2}$  in. for the liquid line and  $1\frac{3}{8}$  in. for the suction line.

For extended line lengths over 100 feet, contact your ICP representative or application engineer.

## IV. Determine fan rpm and bhp (brake horsepower).

Refer to the FAS Air Handler Catalog – Fan Performance table. Enter the Air Handler Fan Performance table at FAS120 at 4000 cfm and move to the External Static Pressure (ESP) column. Note that the conditions require 803 rpm at 1.77 bhp.

## V. Determine motor and drive.

Enter the Fan Motor Data tables and find the standard motor for FAS120 unit rated at 2.4 Hp. Since the bhp required is 1.77, a standard motor satisfies the requirement and should be used.

Next, find the type of drive that satisfies the 803 rpm requirement in the Drive Data tables. For the FAS120 unit, the Standard Drive table shows an rpm range of 666-863. Since the rpm required is 803, the standard drive satisfies the requirement and should be used.

# CONTROLS

## Operating sequences

When the wall thermostat calls for cooling, terminals G and Y1 are energized. As a result, the indoor fan contactor (IFC) and the compressor contactor (C1) are energized, causing the indoor fan motor (IFM), compressor #1, and outdoor fans (OFM) to start. The field-supplied and field-installed liquid line valve also opens, allowing the system to function in Cooling mode.

If the unit has 2 stages of cooling, the wall thermostat will additionally energize Y2. The Y2 signal will energize compressor contactor #2 (C2), causing compressor #2 to start. For CAS072(G,H), the Compressor Loader Plug is energized, causing the second compressor stage to start.

Regardless of the number of stages, the field-supplied liquid line valve shall open and the outdoor fan motors(OFM) runs continuously while unit is cooling.

When cooling demand decrease, the thermostat will de-energize Y2. Y2 signal will de-energize compressor contactor #2 (C2), causing compressor #2 to stop. For CAS072(G,H), the Compressor Loader Plug is de-energized, causing the second compressor stage to stop.

When cooling demand has been satisfied, the thermostat will de-energize Y1, and G terminals. Y1 and G signal will de-energize compressor contactor #1 (C1), causing compressor #1 to stop. If the wall thermostat is set to continuous (CONT), the indoor fan motor will continue to operate. Otherwise, the indoor fan motor will stop.

The outdoor fan motors (OFM) will turn off and field-supplied liquid line valve shall close, minimizing the potential for refrigerant migration.

# TYPICAL WIRING SCHEMATIC

SCHEMATIC  
15T 460V TANDEM

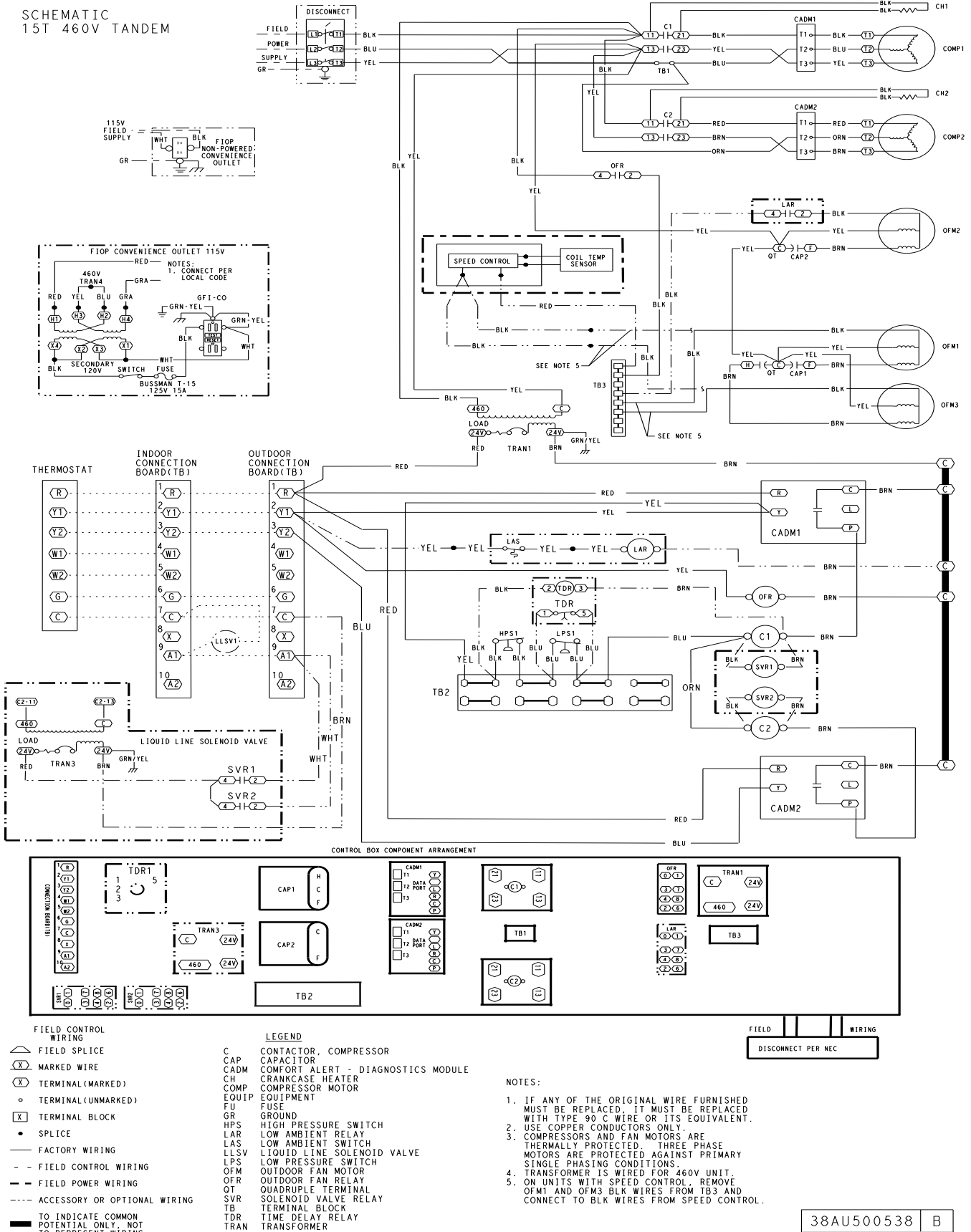

38AU500538 B

C150227

## Typical CAS181 Single Circuit

# TYPICAL WIRING SCHEMATIC (cont.)

SCHEMATIC  
15T 460V DUAL

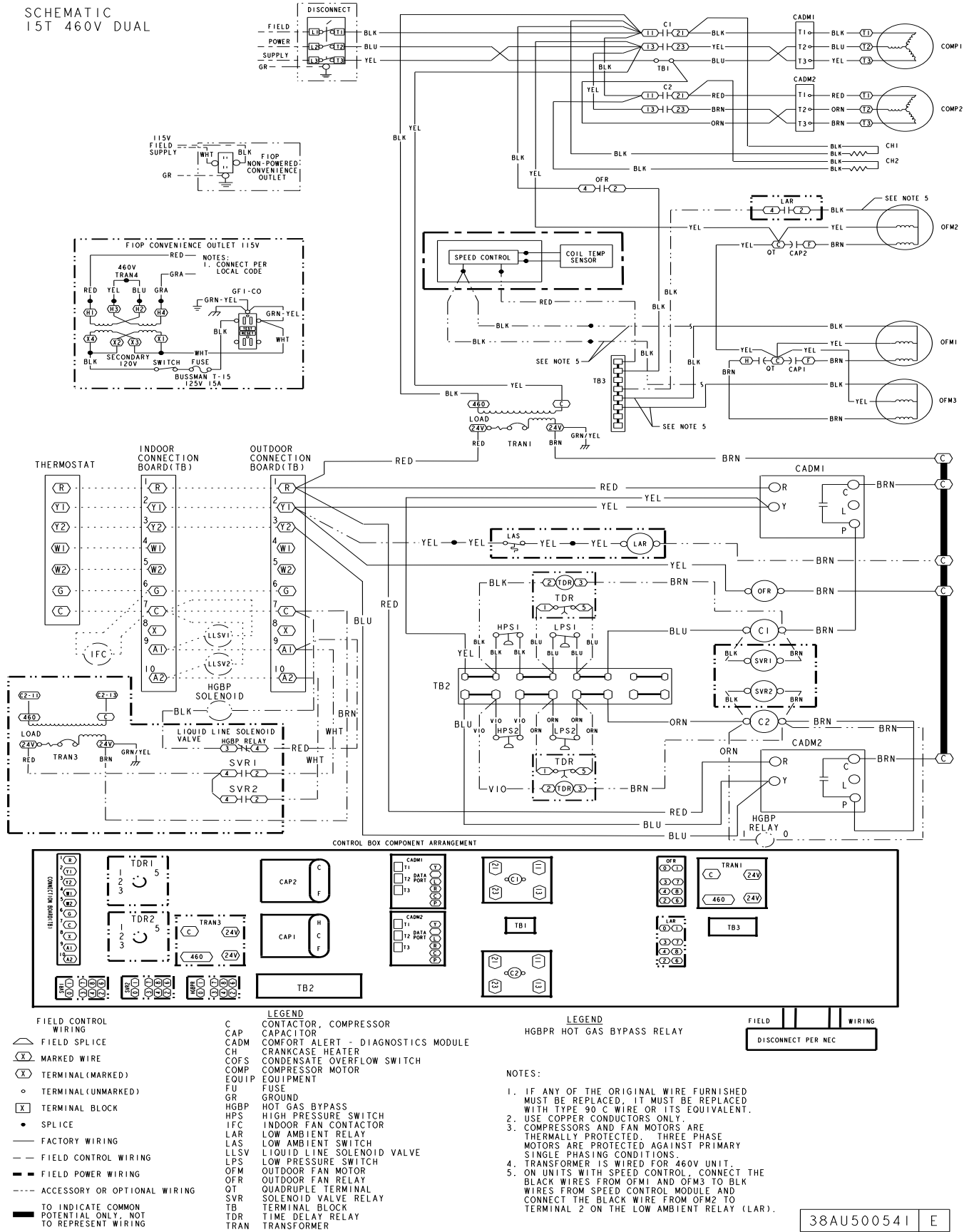

38AU500541 E

C150228

## Typical CAS180 Dual Circuit

# PERFORMANCE DATA

**CAS072**

**CONDENSER ONLY RATINGS**

SST (°F)		AIR TEMPERATURE ENTERING CONDENSER (°F)					
		80	85	95	100	105	115
20	TC	46.7	45.1	41.7	39.8	37.9	33.9
	KW	4.04	4.27	4.77	5.04	5.32	5.93
	SDT	91.6	96.4	105.9	110.6	115.3	124.7
25	TC	51.8	50.0	46.4	44.5	42.5	38.3
	KW	4.06	4.29	4.79	5.05	5.33	5.95
	SDT	92.7	97.5	106.9	111.6	116.3	125.6
30	TC	57.0	55.2	51.4	49.4	47.3	42.9
	KW	4.07	4.30	4.80	5.07	5.35	5.96
	SDT	93.9	98.6	108.1	112.7	117.4	126.7
35	TC	62.7	60.8	56.8	54.6	52.4	47.8
	KW	4.09	4.32	4.81	5.08	5.36	5.98
	SDT	95.1	99.8	109.2	113.9	118.6	127.8
40	TC	68.7	66.7	62.5	60.2	57.9	53.0
	KW	4.11	4.34	4.83	5.10	5.38	5.99
	SDT	96.5	101.1	110.5	115.1	119.7	128.8
45	TC	75.2	73.1	68.5	66.2	63.7	58.6
	KW	4.13	4.36	4.84	5.10	5.38	5.99
	SDT	97.9	102.5	111.8	116.3	120.9	129.9
50	TC	82.2	79.9	75.1	72.5	69.9	64.4
	KW	4.15	4.37	4.85	5.12	5.39	6.00
	SDT	99.4	104.0	113.1	117.6	122.2	131.1

**NOTE:**

Condensing unit only ratings are at 45°F SST and 95°F entering-air temperature. EER = 12.5

**CAS091**

**CONDENSER ONLY RATINGS**

SST (°F)		AIR TEMPERATURE ENTERING CONDENSER (°F)					
		80	85	95	100	105	115
20	TC	65.2	63.2	59.1	57.0	54.8	50.5
	KW	5.04	5.33	5.98	6.34	6.73	7.60
	SDT	95.3	100.2	109.8	114.7	119.5	129.2
25	TC	71.3	69.2	64.8	62.6	60.3	55.7
	KW	5.12	5.42	6.07	6.42	6.81	7.66
	SDT	96.4	101.2	110.8	115.6	120.4	129.9
30	TC	77.8	75.5	70.9	68.5	66.2	61.3
	KW	5.22	5.51	6.16	6.51	6.89	7.74
	SDT	97.6	102.4	111.9	116.6	121.3	130.7
35	TC	84.8	82.4	77.5	75.0	72.4	67.2
	KW	5.32	5.61	6.26	6.61	6.99	7.83
	SDT	98.8	103.5	112.9	117.6	122.3	131.6
40	TC	92.3	89.7	84.5	81.8	79.0	73.5
	KW	5.44	5.73	6.37	6.72	7.10	7.94
	SDT	100.1	104.8	114.2	118.8	123.5	132.7
45	TC	100.3	97.5	91.9	89.0	86.1	80.1
	KW	5.57	5.86	6.50	6.85	7.23	8.07
	SDT	101.6	106.2	115.5	120.2	124.8	133.9
50	TC	108.7	105.8	99.8	96.7	93.6	87.3
	KW	5.71	6.00	6.64	7.00	7.38	8.21
	SDT	103.1	107.8	117.0	121.6	126.2	135.3

**NOTE:**

Condensing unit only ratings are at 45°F SST and 95°F entering-air temperature. EER = 12.9

**LEGEND:**

- kW – Compressor Power
- SDT – Saturated Discharge Temperature at Compressor (°F)
- SST – Saturated Suction Temperature (°F)
- TC – Gross Cooling Capacity (1000 Btuh)



## PERFORMANCE DATA (cont.)

**CAS121**

**CONDENSER ONLY RATINGS**

SST (°F)		AIR TEMPERATURE ENTERING CONDENSER (°F)					
		80	85	95	100	105	115
20	TC	78.0	75.4	70.1	67.3	64.6	58.9
	KW	6.03	6.44	7.31	7.76	8.23	9.21
	SDT	94.0	98.7	108.2	113.0	117.7	127.2
25	TC	86.1	83.3	77.6	74.7	71.7	65.7
	KW	6.11	6.53	7.41	7.87	8.36	9.36
	SDT	95.2	100.0	109.4	114.2	118.9	128.2
30	TC	94.7	91.8	85.6	82.5	79.4	73.0
	KW	6.20	6.62	7.51	7.98	8.47	9.49
	SDT	96.6	101.3	110.7	115.4	120.0	129.2
35	TC	104.0	100.8	94.3	90.9	87.6	80.7
	KW	6.30	6.71	7.61	8.09	8.58	9.62
	SDT	98.1	102.7	112.0	116.6	121.2	130.4
40	TC	113.9	110.4	103.4	99.9	96.2	88.9
	KW	6.39	6.81	7.71	8.20	8.70	9.75
	SDT	99.5	104.2	113.4	117.9	122.5	131.6
45	TC	124.3	120.6	113.1	109.2	105.4	97.5
	KW	6.49	6.92	7.83	8.32	8.82	9.89
	SDT	101.1	105.7	114.8	119.4	123.9	132.9
50	TC	135.4	131.4	123.3	119.2	115.0	106.5
	KW	6.61	7.04	7.96	8.45	8.96	10.03
	SDT	102.8	107.3	116.4	120.9	125.4	134.3

**NOTE:**

Condensing unit only ratings are at 45°F SST and 95°F entering-air temperature. EER = 13.35

**CAS120 Dual Circuit**

**CONDENSER ONLY RATINGS**

SST (°F)		AIR TEMP ENT CONDENSER (°F)					
		85	95	100	105	115	120
20	TC	75.29	69.95	67.18	64.32	58.42	55.21
	KW	6.88	7.89	8.43	8.96	10.04	10.53
	SDT	102.3	111.4	116.1	120.5	129.6	133.7
25	TC	83.12	77.31	74.32	71.28	64.99	61.76
	KW	6.97	7.98	8.53	9.07	10.18	10.73
	SDT	103.6	112.6	117.3	121.8	130.7	135.1
30	TC	91.41	85.21	81.99	78.76	72.08	68.58
	KW	7.06	8.08	8.63	9.18	10.31	10.87
	SDT	104.9	114.0	118.5	122.9	131.8	136.1
35	TC	100.35	93.69	90.26	86.76	85.11	75.65
	KW	7.15	8.18	8.73	9.29	10.42	10.99
	SDT	106.3	115.2	119.8	124.2	132.9	137.1
40	TC	109.90	102.58	98.84	95.06	87.13	83.07
	KW	7.25	8.29	8.83	9.39	10.54	11.12
	SDT	107.6	116.6	121.0	125.4	134.0	138.2
45	TC	119.86	111.84	107.74	103.56	95.02	90.54
	KW	7.36	8.39	8.93	9.49	10.64	11.22
	SDT	109.0	117.9	122.3	126.6	135.1	139.2
50	TC	130.20	121.39	116.90	112.33	103.07	98.17
	KW	7.48	8.51	9.04	9.60	10.75	11.33
	SDT	110.5	119.2	123.5	127.8	136.2	140.2

**NOTE:**

Condensing unit only ratings are at 45°F SST and 95°F entering-air temperature. EER = 11.24

**LEGEND:**

kW - Compressor Power

SDT - Saturated Discharge Temperature at Compressor (°F)

SST - Saturated Suction Temperature (°F)

TC - Gross Cooling Capacity (1000 Btuh)

## PERFORMANCE DATA (cont.)

**CAS151**

**CONDENSER ONLY RATINGS**

SST (°F)		AIR TEMPERATURE ENTERING CONDENSER (°F)					
		80	85	95	100	105	115
20	TC	100.8	97.4	90.3	86.6	83.0	75.5
	KW	8.48	8.97	10.00	10.53	11.07	12.19
	SDT	98.0	102.6	111.8	116.4	120.9	130.0
25	TC	111.5	107.8	100.2	96.3	92.4	84.7
	KW	8.66	9.15	10.20	10.75	11.31	12.47
	SDT	99.6	104.1	113.2	117.7	122.3	131.3
30	TC	122.9	118.9	110.7	106.6	102.4	93.9
	KW	8.84	9.35	10.41	10.97	11.55	12.75
	SDT	101.3	105.8	114.8	119.3	123.8	132.7
35	TC	134.9	130.6	121.9	117.4	113.0	103.8
	KW	9.05	9.55	10.64	11.21	11.80	13.03
	SDT	103.1	107.6	116.5	120.9	125.4	134.2
40	TC	147.7	143.0	133.7	128.9	124.1	114.3
	KW	9.27	9.78	10.88	11.47	12.07	13.32
	SDT	105.1	109.5	118.3	122.8	127.1	135.8
45	TC	161.1	156.2	146.1	141.0	135.8	125.4
	KW	9.51	10.03	11.15	11.73	12.34	13.61
	SDT	107.2	111.6	120.3	124.7	129.0	137.5
50	TC	175.4	170.1	159.3	153.8	148.3	137.1
	KW	9.78	10.30	11.42	12.02	12.63	13.92
	SDT	109.5	113.8	122.4	126.7	130.9	139.4

**NOTE:**

Condensing unit only ratings are at 45°F SST and 95°F entering-air temperature. EER = 12.47

**CAS150 Dual Circuit**

**CONDENSER ONLY RATINGS**

SST (°F)		AIR TEMP ENT CONDENSER (°F)					
		85	95	100	105	115	120
20	TC	93.24	86.18	82.60	78.94	71.54	67.78
	KW	9.22	10.36	10.96	11.56	12.76	13.37
	SDT	104.4	113.3	117.8	122.2	130.9	135.2
25	TC	103.39	95.91	92.05	88.15	80.16	76.08
	KW	9.42	10.60	11.21	11.83	13.10	13.73
	SDT	106.1	114.9	119.3	123.7	132.3	136.6
30	TC	114.29	106.19	102.04	97.79	89.15	84.74
	KW	9.63	10.84	11.46	12.10	13.41	14.07
	SDT	107.8	116.6	120.9	125.3	133.8	138.0
35	TC	125.69	116.93	112.44	107.84	105.72	93.69
	KW	9.84	11.07	11.71	12.36	13.70	14.38
	SDT	109.5	118.2	122.6	126.8	135.2	139.4
40	TC	137.57	128.07	123.21	118.21	108.08	102.90
	KW	10.05	11.30	11.95	12.61	13.98	14.68
	SDT	111.3	119.9	124.2	128.4	136.7	140.8
45	TC	149.86	139.53	134.26	128.83	117.83	112.22
	KW	10.27	11.53	12.18	12.85	14.24	14.95
	SDT	113.1	121.6	125.8	130.0	138.1	142.1
50	TC	162.51	151.29	145.56	139.64	127.71	121.55
	KW	10.50	11.76	12.42	13.09	14.48	15.20
	SDT	114.9	123.3	127.5	131.6	139.6	143.5

**NOTE:**

Condensing unit only ratings are at 45°F SST and 95°F entering-air temperature. EER = 10.5

**LEGEND:**

kW - Compressor Power

SDT - Saturated Discharge Temperature at Compressor (°F)

SST - Saturated Suction Temperature (°F)

TC - Gross Cooling Capacity (1000 Btuh)

## PERFORMANCE DATA (cont.)

### CAS181

### CONDENSER ONLY RATINGS

SST (°F)		AIR TEMPERATURE ENTERING CONDENSER (°F)					
		80	85	95	105	115	125
20	TC	125.5	121.8	114.2	106.6	99.7	79.7
	KW	10.5	11.2	12.6	14.2	16.0	17.5
	SDT	98.6	103.4	113.0	122.7	134.9	136.0
25	TC	138.7	134.7	126.5	118.1	109.3	98.5
	KW	10.7	11.4	12.8	14.3	16.0	17.9
	SDT	100.0	104.7	114.2	123.6	132.9	140.5
30	TC	152.9	148.6	139.8	130.7	120.9	104.9
	KW	10.9	11.6	13.0	14.6	16.2	17.8
	SDT	101.4	106.2	115.5	125.0	133.6	139.4
35	TC	168.2	163.5	154.1	144.2	133.6	121.2
	KW	11.2	11.8	13.2	14.8	16.5	18.1
	SDT	102.9	107.5	117.0	126.2	134.8	142.1
40	TC	184.9	179.4	169.3	158.7	147.6	135.1
	KW	11.5	12.0	13.5	15.1	16.8	18.5
	SDT	105.2	108.9	118.5	127.7	136.7	144.5
45	TC	202.1	196.7	185.7	174.3	162.5	150.4
	KW	11.7	12.4	13.9	15.6	17.5	19.6
	SDT	106.4	111.2	120.9	130.7	140.4	150.2
50	TC	220.6	214.7	202.1	190.0	174.6	159.6
	KW	11.9	12.6	13.9	15.4	16.9	18.5
	SDT	107.2	111.7	120.4	129.4	136.9	144.9

**NOTE:**

Condensing unit only ratings are at 45°F SST and 95°F entering-air temperature. EER = 12.53

### CAS180 Dual Circuit

### CONDENSER ONLY RATINGS

SST (°F)		AIR TEMPERATURE ENTERING CONDENSER (°F)					
		80	85	95	105	115	125
20	TC	127.6	123.7	116.0	108.1	99.7	90.2
	KW	10.0	10.6	11.9	13.4	14.9	16.6
	SDT	96.0	100.5	109.8	119.2	128.3	137.0
25	TC	140.9	136.7	128.3	119.5	110.4	101.2
	KW	10.0	10.6	11.9	13.4	14.9	16.6
	SDT	96.0	100.5	109.8	119.2	128.3	137.0
30	TC	155.0	150.5	141.3	132.0	122.3	111.4
	KW	10.4	11.0	12.3	13.7	15.3	17.0
	SDT	98.7	103.3	112.4	121.5	130.6	139.1
35	TC	170.1	165.3	155.4	145.2	134.4	123.3
	KW	10.6	11.2	12.5	14.0	15.5	17.2
	SDT	100.1	104.7	113.8	122.8	131.7	140.4
40	TC	186.3	181.0	170.3	159.0	147.3	134.9
	KW	10.8	11.4	12.8	14.2	15.8	17.4
	SDT	101.6	106.1	115.1	124.0	132.8	141.4
45	TC	203.4	197.6	185.7	173.5	160.6	147.2
	KW	11.1	11.7	13.0	14.4	16.0	17.6
	SDT	103.2	107.6	116.5	125.4	134.0	142.5
50	TC	221.4	214.9	202.0	188.6	174.5	159.7
	KW	11.4	12.0	13.3	14.7	16.2	17.9
	SDT	104.8	109.2	118.0	126.7	135.2	143.5

**NOTE:**

Condensing unit only ratings are at 45°F SST and 95°F entering-air temperature. EER = 12.52

**LEGEND:**

kW – Compressor Power

SDT – Saturated Discharge Temperature at Compressor (°F)

SST – Saturated Suction Temperature (°F)

TC – Gross Cooling Capacity (1000 Btuh)

## PERFORMANCE DATA (cont.)

### CAS241

### CONDENSER ONLY RATINGS

SST (°F)		AIR TEMPERATURE ENTERING CONDENSER (°F)					
		80	85	95	105	115	125
20	TC	159.2	154.5	144.5	133.9	122.5	110.2
	KW	13.0	13.7	15.3	17.1	19.2	21.5
	SDT	97.3	101.8	110.6	119.3	127.9	136.5
25	TC	176.1	171.0	160.2	148.8	136.5	123.2
	KW	13.2	14.0	15.6	17.4	19.5	21.8
	SDT	98.9	103.3	112.0	120.7	129.2	137.6
30	TC	194.2	188.6	176.9	164.5	151.3	136.9
	KW	13.5	14.3	15.9	17.7	19.7	22.0
	SDT	100.6	104.9	113.6	122.1	130.5	138.8
35	TC	213.5	207.4	194.7	181.2	166.8	151.2
	KW	13.8	14.6	16.2	18.0	20.0	22.3
	SDT	102.4	106.7	115.2	123.6	131.9	140.1
40	TC	234.1	227.4	213.5	198.8	183.1	166.1
	KW	14.2	14.9	16.5	18.3	20.3	22.6
	SDT	104.3	108.5	116.9	125.2	133.3	141.4
45	TC	255.9	248.6	233.3	217.3	200.1	181.7
	KW	14.6	15.3	16.9	18.7	20.7	22.9
	SDT	106.3	110.5	118.7	126.8	134.9	142.7
50	TC	279.0	270.9	254.2	236.7	218.1	197.8
	KW	15.1	15.8	17.3	19.1	21.1	23.2
	SDT	108.5	112.5	120.6	128.6	136.5	144.1

**NOTE:**

Condensing unit only ratings are at 45°F SST and 95°F entering-air temperature. EER = 12.87

### CAS240 Dual Circuit

### CONDENSER ONLY RATINGS

SST (°F)		AIR TEMPERATURE ENTERING CONDENSER (°F)					
		80	85	95	105	115	125
20	TC	160.3	155.5	145.3	134.3	122.5	109.6
	KW	12.7	13.4	15.0	16.8	18.8	21.1
	SDT	97.0	101.5	110.3	119.1	127.7	136.3
25	TC	177.2	171.9	160.8	149.0	136.3	122.3
	KW	12.7	13.4	15.0	16.8	18.8	21.1
	SDT	97.0	101.5	110.3	119.1	127.7	136.3
30	TC	195.1	189.4	177.4	164.5	150.7	135.6
	KW	13.2	13.9	15.5	17.3	19.3	21.5
	SDT	100.3	104.6	113.3	121.8	130.3	138.6
35	TC	214.3	208.0	194.9	180.9	165.9	149.5
	KW	13.5	14.3	15.8	17.6	19.6	21.8
	SDT	102.1	106.3	114.9	123.3	131.7	139.8
40	TC	234.6	227.7	213.4	198.2	181.7	163.9
	KW	13.9	14.6	16.2	17.9	19.9	22.1
	SDT	104.0	108.2	116.6	124.9	133.1	141.1
45	TC	256.3	258.7	242.3	224.9	206.2	186.1
	KW	14.3	15.2	16.7	18.5	20.4	22.5
	SDT	106.0	111.1	119.2	127.4	135.4	143.1
50	TC	279.1	272.0	254.7	236.3	216.6	195.4
	KW	14.7	15.5	17.0	18.7	20.6	22.7
	SDT	108.1	112.3	120.4	128.4	136.4	143.9

**NOTE:**

Condensing unit only ratings are at 45°F SST and 95°F entering-air temperature. EER = 13.55

**LEGEND:**

kW – Compressor Power

SDT – Saturated Discharge Temperature at Compressor (°F)

SST – Saturated Suction Temperature (°F)

TC – Gross Cooling Capacity (1000 Btuh)

# PERFORMANCE DATA (cont.)

CAS072 – FAS072

COMBINATION RATINGS

				AMBIENT TEMPERATURE														
				85			95			105			115			125		
				EA (db)			EA (db)			EA (db)			EA (db)			EA (db)		
				75	80	85	75	80	85	75	80	85	75	80	85	75	80	85
1800 Cfm	58	THC	65.8	65.8	74.1	63.4	63.4	71.4	60.7	60.7	68.3	58.3	58.3	65.7	54.7	54.7	61.6	
		SHC	57.4	65.8	74.1	55.3	63.4	71.4	53.0	60.7	68.3	50.9	58.3	65.7	47.8	54.7	61.6	
	62	THC	68.1	68.1	70.7	65.2	65.2	69.2	62.0	62.0	67.6	58.1	58.1	65.7	54.6	54.6	55.4	
		SHC	51.9	61.3	70.7	50.4	59.8	69.2	48.9	58.3	67.6	47.1	56.4	65.7	36.3	45.9	55.4	
	67	THC	74.0	74.0	74.0	70.9	70.9	70.9	67.3	67.3	67.3	63.4	63.4	63.4	56.7	56.7	56.7	
		SHC	42.3	51.8	61.3	41.0	50.5	59.9	39.5	49.0	58.4	37.9	47.3	56.8	35.3	44.9	54.4	
	72	THC	80.7	80.7	80.7	77.3	77.3	77.3	73.6	73.6	73.6	69.4	69.4	69.4	63.2	63.2	63.2	
		SHC	32.7	42.2	51.8	31.4	40.9	50.4	30.0	39.5	49.0	28.4	37.9	47.4	26.2	35.7	45.3	
	76	THC	–	86.2	86.2	–	82.6	82.6	–	78.6	78.6	–	74.3	74.3	–	70.7	70.7	
		SHC	–	34.5	44.3	–	33.2	43.0	–	31.8	41.6	–	30.3	40.0	–	29.0	38.7	
2100 Cfm	58	THC	69.0	69.0	77.8	66.5	66.5	74.9	63.7	63.7	71.8	61.2	61.2	69.0	–	–	–	
		SHC	60.3	69.0	77.8	58.0	66.5	74.9	55.6	63.7	71.8	53.5	61.2	69.0	–	–	–	
	62	THC	70.2	70.2	77.1	67.2	67.2	75.5	64.0	64.0	73.6	60.4	60.4	70.7	–	–	–	
		SHC	55.7	66.4	77.1	54.2	64.8	75.5	52.5	63.0	73.6	50.2	60.4	70.7	–	–	–	
	67	THC	75.9	75.9	75.9	72.6	72.6	72.6	68.9	68.9	68.9	64.8	64.8	64.8	59.1	59.1	59.9	
		SHC	44.8	55.7	66.5	43.4	54.3	65.1	41.9	52.8	63.6	40.3	51.1	62.0	38.1	49.0	59.9	
	72	THC	82.5	82.5	82.5	79.0	79.0	79.0	75.2	75.2	75.2	70.9	70.9	70.9	63.9	63.9	63.9	
		SHC	33.7	44.6	55.5	32.4	43.3	54.2	31.0	41.8	52.7	29.4	40.3	51.1	26.9	37.9	48.8	
	76	THC	–	88.1	88.1	–	84.3	84.3	–	80.2	80.2	–	75.5	75.5	–	71.8	71.8	
		SHC	–	35.8	47.0	–	34.5	45.6	–	33.0	44.2	–	31.4	42.5	–	30.2	41.2	
2400 Cfm	58	THC	71.7	71.7	80.8	69.0	69.0	77.8	66.1	66.1	74.5	62.6	62.6	70.6	58.9	58.9	66.3	
		SHC	62.6	71.7	80.8	60.3	69.0	77.8	57.7	66.1	74.5	54.7	62.6	70.6	51.4	58.9	66.3	
	62	THC	72.0	72.0	82.7	69.1	69.1	80.8	66.2	66.2	77.4	63.0	63.0	73.6	–	–	–	
		SHC	59.0	70.9	82.7	57.4	69.1	80.8	55.0	66.2	77.4	52.3	63.0	73.6	–	–	–	
	67	THC	77.3	77.3	77.3	74.0	74.0	74.0	70.2	70.2	70.2	66.1	66.1	66.9	62.5	62.5	65.0	
		SHC	47.1	59.3	71.5	45.7	57.9	70.1	44.2	56.4	68.6	42.6	54.7	66.9	41.0	53.0	65.0	
	72	THC	84.0	84.0	84.0	80.4	80.4	80.4	76.4	76.4	76.4	71.8	71.8	71.8	67.5	67.5	67.5	
		SHC	34.6	46.9	59.1	33.3	45.5	57.8	31.9	44.1	56.3	30.2	42.4	54.6	28.7	40.8	52.9	
	76	THC	–	89.5	89.5	–	85.7	85.7	–	81.4	81.4	–	76.7	76.7	–	–	–	
		SHC	–	36.9	49.4	–	35.6	48.1	–	34.2	46.6	–	32.6	45.0	–	–	–	
2700 Cfm	58	THC	73.9	73.9	83.3	71.2	71.2	80.2	68.1	68.1	76.7	64.8	64.8	73.0	58.6	58.6	66.0	
		SHC	64.6	73.9	83.3	62.2	71.2	80.2	59.5	68.1	76.7	56.5	64.8	73.0	51.2	58.6	66.0	
	62	THC	74.0	74.0	86.5	71.3	71.3	83.3	68.2	68.2	79.7	64.8	64.8	75.8	–	–	–	
		SHC	61.5	74.0	86.5	59.2	71.3	83.3	56.6	68.2	79.7	53.8	64.8	75.8	–	–	–	
	67	THC	78.5	78.5	78.5	75.1	75.1	75.1	71.2	71.2	73.2	67.0	67.0	71.5	63.2	63.2	69.4	
		SHC	49.3	62.7	76.2	47.9	61.3	74.8	46.4	59.8	73.2	44.7	58.1	71.5	43.0	56.2	69.4	
	72	THC	85.1	85.1	85.1	81.4	81.4	81.4	77.3	77.3	77.3	72.6	72.6	72.6	65.3	65.3	65.3	
		SHC	35.5	49.0	62.5	34.2	47.6	61.1	32.7	46.1	59.6	31.1	44.5	57.9	28.6	42.2	55.7	
	76	THC	–	90.7	90.7	–	86.7	86.7	–	82.3	82.3	–	–	–	–	–	–	
		SHC	–	38.1	51.8	–	36.7	50.4	–	35.3	48.9	–	–	–	–	–	–	
3000 Cfm	58	THC	75.9	75.9	85.5	73.0	73.0	82.3	69.8	69.8	78.7	66.3	66.3	74.7	62.4	62.4	70.4	
		SHC	66.3	75.9	85.5	63.8	73.0	82.3	61.0	69.8	78.7	57.9	66.3	74.7	54.5	62.4	70.4	
	62	THC	75.9	75.9	88.8	73.1	73.1	85.4	69.9	69.9	81.7	66.4	66.4	77.6	60.2	60.2	70.4	
		SHC	63.1	75.9	88.8	60.7	73.1	85.4	58.0	69.9	81.7	55.1	66.4	77.6	50.0	60.2	70.4	
	67	THC	79.5	79.5	80.7	76.0	76.0	79.3	72.1	72.1	77.6	67.9	67.9	75.7	63.7	63.7	73.5	
		SHC	51.4	66.0	80.7	49.9	64.6	79.3	48.4	63.0	77.6	46.7	61.2	75.7	44.8	59.2	73.5	
	72	THC	86.1	86.1	86.1	82.3	82.3	82.3	78.0	78.0	78.0	73.3	73.3	73.3	69.6	69.6	69.6	
		SHC	36.3	51.0	65.8	35.0	49.7	64.4	33.5	48.1	62.8	31.9	46.5	61.1	30.5	44.9	59.3	
	76	THC	–	91.6	91.6	–	87.6	87.6	–	–	–	–	–	–	–	–	–	
		SHC	–	39.1	54.0	–	37.8	52.7	–	–	–	–	–	–	–	–	–	

– Not operational

THC – Total Cooling Capacity, Gross (1,000 Btuh)

SHC – Sensible Cooling Capacity, Gross (1,000 Btuh)

# PERFORMANCE DATA (cont.)

CAS072 – FAS091

COMBINATION RATINGS

			AMBIENT TEMPERATURE														
			85			95			105			115			125		
			EA (db)			EA (db)			EA (db)			EA (db)			EA (db)		
			75	80	85	75	80	85	75	80	85	75	80	85	75	80	85
2250 Cfm	58	THC	71.6	71.6	80.7	69.1	69.1	77.9	66.2	66.2	74.6	63.2	63.2	72.2	–	–	–
		SHC	62.5	71.6	80.7	60.3	69.1	77.9	57.8	66.2	74.6	55.0	63.2	72.2	–	–	–
	62	THC	72.5	72.5	81.5	69.6	69.6	79.6	66.6	66.6	76.6	63.2	63.2	73.2	–	–	–
		SHC	58.5	70.0	81.5	56.9	68.2	79.6	54.6	65.6	76.6	52.1	62.7	73.2	–	–	–
	67	THC	78.1	78.1	78.1	74.8	74.8	74.8	71.2	71.2	71.2	67.0	67.0	67.7	60.9	60.9	64.5
		SHC	46.9	58.7	70.5	45.6	57.4	69.1	44.1	55.9	67.6	42.4	54.2	66.0	40.1	52.0	63.8
72	THC	84.9	84.9	84.9	81.4	81.4	81.4	77.4	77.4	77.4	73.1	73.1	73.1	68.9	68.9	68.9	
	SHC	34.9	46.7	58.6	33.6	45.4	57.3	32.1	43.9	55.8	30.5	42.3	54.1	29.0	40.7	52.5	
76	THC	–	90.6	90.6	–	86.9	86.9	–	82.5	82.5	–	77.1	77.1	–	–	–	
	SHC	–	37.1	49.1	–	35.9	47.9	–	33.5	43.4	–	31.9	41.8	–	–	–	
2600 Cfm	58	THC	74.8	74.8	84.2	72.1	72.1	81.3	69.0	69.0	77.8	65.7	65.7	74.0	62.2	62.2	70.0
		SHC	65.3	74.8	84.2	62.9	72.1	81.3	60.3	69.0	77.8	57.3	65.7	74.0	54.3	62.2	70.0
	62	THC	74.9	74.9	87.2	72.1	72.1	84.3	69.1	69.1	80.8	65.7	65.7	76.8	61.7	61.7	72.1
		SHC	62.0	74.6	87.2	60.0	72.1	84.3	57.4	69.1	80.8	54.6	65.7	76.8	51.2	61.7	72.1
	67	THC	79.8	79.8	79.8	76.3	76.3	76.4	72.6	72.6	74.2	68.4	68.4	71.9	63.9	63.9	69.8
		SHC	49.7	63.1	76.5	48.3	61.8	75.1	46.8	60.2	73.6	45.1	58.5	71.9	43.3	56.5	69.8
72	THC	86.5	86.5	86.5	82.9	82.9	82.9	78.8	78.8	78.8	74.3	74.3	74.3	69.5	69.5	69.5	
	SHC	36.0	49.4	62.9	34.7	48.1	61.6	33.2	46.6	60.1	31.6	45.0	58.4	29.9	43.3	56.7	
76	THC	–	92.3	92.3	–	87.7	87.7	–	–	–	–	–	–	–	–	–	
	SHC	–	38.5	52.2	–	36.5	49.2	–	–	–	–	–	–	–	–	–	
3000 Cfm	58	THC	77.6	77.6	87.4	74.8	74.8	84.2	71.5	71.5	80.6	67.9	67.9	76.5	64.9	64.9	73.1
		SHC	67.7	77.6	87.4	65.3	74.8	84.2	62.5	71.5	80.6	59.3	67.9	76.5	56.7	64.9	73.1
	62	THC	77.7	77.7	90.8	74.8	74.8	87.5	71.6	71.6	83.7	67.9	67.9	79.4	64.9	64.9	75.9
		SHC	64.5	77.7	90.8	62.1	74.8	87.5	59.5	71.6	83.7	56.4	67.9	79.4	53.9	64.9	75.9
	67	THC	81.2	81.2	83.0	77.7	77.7	81.6	73.9	73.9	80.0	69.6	69.6	78.0	65.3	65.3	74.4
		SHC	52.7	67.8	83.0	51.3	66.4	81.6	49.8	64.9	80.0	48.0	63.0	78.0	44.5	59.4	74.4
72	THC	87.9	87.9	87.9	84.2	84.2	84.2	80.0	80.0	80.0	75.3	75.3	75.3	70.2	70.2	70.2	
	SHC	37.1	52.3	67.6	35.8	51.0	66.2	34.3	49.5	64.7	32.7	47.9	63.0	31.0	46.1	61.2	
76	THC	–	–	–	–	–	–	–	–	–	–	–	–	–	–	–	
	SHC	–	–	–	–	–	–	–	–	–	–	–	–	–	–	–	
3400 Cfm	58	THC	79.7	79.7	89.8	76.8	76.8	86.4	73.4	73.4	82.7	69.6	69.6	78.4	64.8	64.8	73.0
		SHC	69.6	79.7	89.8	67.0	76.8	86.4	64.1	73.4	82.7	60.8	69.6	78.4	56.6	64.8	73.0
	62	THC	79.8	79.8	93.3	76.8	76.8	89.8	73.5	73.5	85.9	69.7	69.7	81.4	65.6	65.6	76.8
		SHC	66.3	79.8	93.3	63.8	76.8	89.8	61.0	73.5	85.9	57.8	69.7	81.4	54.5	65.6	76.8
	67	THC	82.3	82.3	88.8	78.8	78.8	87.3	74.9	74.9	85.5	70.6	70.6	83.2	–	–	–
		SHC	55.4	72.1	88.8	53.9	70.6	87.3	52.4	68.9	85.5	50.5	66.8	83.2	–	–	–
72	THC	88.9	88.9	88.9	85.1	85.1	85.1	80.8	80.8	80.8	76.1	76.1	76.1	–	–	–	
	SHC	38.2	55.0	71.9	36.9	53.7	70.5	35.4	52.2	69.0	33.8	50.5	67.3	–	–	–	
76	THC	–	–	–	–	–	–	–	–	–	–	–	–	–	–	–	
	SHC	–	–	–	–	–	–	–	–	–	–	–	–	–	–	–	
3750 Cfm	58	THC	81.5	81.5	91.9	78.5	78.5	88.4	75.0	75.0	84.5	71.1	71.1	80.1	64.7	64.7	72.9
		SHC	71.2	81.5	91.9	68.5	78.5	88.4	65.5	75.0	84.5	62.1	71.1	80.1	56.5	64.7	72.9
	62	THC	81.6	81.6	95.4	78.5	78.5	91.8	75.1	75.1	87.8	71.2	71.2	83.2	66.3	66.3	77.5
		SHC	67.8	81.6	95.4	65.2	78.5	91.8	62.4	75.1	87.8	59.1	71.2	83.2	55.1	66.3	77.5
	67	THC	83.2	83.2	93.9	79.7	79.7	92.2	75.8	75.8	90.3	71.5	71.5	87.7	–	–	–
		SHC	57.7	75.8	93.9	56.2	74.2	92.2	54.6	72.4	90.3	52.6	70.2	87.7	–	–	–
72	THC	89.7	89.7	89.7	85.8	85.8	85.8	81.5	81.5	81.5	76.8	76.8	76.8	–	–	–	
	SHC	39.1	57.4	75.7	37.8	56.0	74.3	36.3	54.5	72.7	34.7	52.8	71.0	–	–	–	
76	THC	–	–	–	–	–	–	–	–	–	–	–	–	–	–	–	
	SHC	–	–	–	–	–	–	–	–	–	–	–	–	–	–	–	

– Not operational

THC – Total Cooling Capacity, Gross (1,000 Btuh)

SHC – Sensible Cooling Capacity, Gross (1,000 Btuh)

# PERFORMANCE DATA (cont.)

CAS091 – FAS091

COMBINATION RATINGS

			AMBIENT TEMPERATURE															
			85			95			105			115			125			
			EA (db)			EA (db)			EA (db)			EA (db)			EA (db)			
			75	80	85	75	80	85	75	80	85	75	80	85	75	80	85	
2250 Cfm	EA (wb)	58	THC	84.6	84.6	95.4	81.7	81.7	92.1	78.5	78.5	88.5	75.5	75.5	85.1	70.7	70.7	79.7
		SHC	73.9	84.6	95.4	71.3	81.7	92.1	68.5	78.5	88.5	65.9	75.5	85.1	61.7	70.7	79.7	
	62	THC	88.2	88.2	89.4	84.6	84.6	87.6	80.7	80.7	85.6	76.9	76.9	83.6	73.2	73.2	81.3	
		SHC	66.1	77.7	89.4	64.3	75.9	87.6	62.4	74.0	85.6	60.5	72.0	83.6	58.5	69.9	81.3	
	67	THC	95.5	95.5	95.5	91.5	91.5	91.5	87.3	87.3	87.3	82.7	82.7	82.7	76.1	76.1	76.1	
		SHC	54.1	65.8	77.5	52.3	64.1	75.8	50.5	62.2	74.0	48.6	60.3	72.0	46.0	57.8	69.5	
	72	THC	103.4	103.4	103.4	99.2	99.2	99.2	94.6	94.6	94.6	89.6	89.6	89.6	82.3	82.3	82.3	
		SHC	41.8	53.7	65.5	40.2	52.0	63.8	38.4	50.2	62.0	36.6	48.3	60.1	33.8	45.6	57.4	
	76	THC	–	109.9	109.9	–	105.4	105.4	–	100.6	100.6	–	95.3	95.3	–	87.8	87.8	
		SHC	–	43.9	56.2	–	42.3	54.7	–	40.6	52.8	–	38.7	50.9	–	36.1	48.3	
2625 Cfm	EA (wb)	58	THC	88.7	88.7	99.9	85.6	85.6	96.4	82.1	82.1	92.5	78.7	78.7	88.7	75.4	75.4	85.0
		SHC	77.4	88.7	99.9	74.7	85.6	96.4	71.7	82.1	92.5	68.8	78.7	88.7	65.8	75.4	85.0	
	62	THC	90.7	90.7	97.2	87.0	87.0	95.3	83.0	83.0	93.1	78.9	78.9	90.6	75.3	75.3	86.4	
		SHC	70.7	84.0	97.2	68.8	82.1	95.3	66.9	80.0	93.1	64.7	77.6	90.6	61.7	74.0	86.4	
	67	THC	97.8	97.8	97.8	93.7	93.7	93.7	89.2	89.2	89.2	84.4	84.4	84.4	76.7	76.7	76.7	
		SHC	57.0	70.4	83.8	55.3	68.7	82.1	53.4	66.8	80.2	51.5	64.8	78.2	48.6	62.0	75.5	
	72	THC	105.7	105.7	105.7	101.3	101.3	101.3	96.5	96.5	96.5	91.5	91.5	91.5	86.2	86.2	86.2	
		SHC	43.0	56.5	70.0	41.4	54.9	68.3	39.6	53.0	66.5	37.8	51.2	64.5	35.8	49.2	62.5	
	76	THC	–	112.2	112.2	–	107.6	107.6	–	102.5	102.5	–	97.0	97.0	–	–	–	
		SHC	–	45.4	59.5	–	43.8	57.8	–	42.0	55.9	–	40.2	54.0	–	–	–	
3000 Cfm	EA (wb)	58	THC	92.0	92.0	103.7	88.7	88.7	99.9	85.1	85.1	95.9	81.2	81.2	91.5	76.0	76.0	85.7
		SHC	80.3	92.0	103.7	77.4	88.7	99.9	74.3	85.1	95.9	70.9	81.2	91.5	66.4	76.0	85.7	
	62	THC	92.9	92.9	104.3	89.2	89.2	102.0	85.1	85.1	99.5	81.4	81.4	95.1	–	–	–	
		SHC	74.9	89.6	104.3	72.9	87.4	102.0	70.7	85.1	99.5	67.6	81.4	95.1	–	–	–	
	67	THC	99.6	99.6	99.6	95.3	95.3	95.3	90.8	90.8	90.8	86.0	86.0	86.0	79.1	79.1	81.7	
		SHC	59.7	74.7	89.8	58.0	73.0	88.0	56.1	71.1	86.1	54.2	69.1	84.1	51.7	66.7	81.7	
	72	THC	107.5	107.5	107.5	103.0	103.0	103.0	98.0	98.0	98.0	92.9	92.9	92.9	88.0	88.0	88.0	
		SHC	44.1	59.2	74.3	42.5	57.5	72.6	40.7	55.7	70.7	38.8	53.8	68.7	37.0	51.8	66.7	
	76	THC	–	114.0	114.0	–	109.1	109.1	–	103.9	103.9	–	98.3	98.3	–	–	–	
		SHC	–	46.9	62.4	–	45.2	60.7	–	43.4	58.8	–	41.5	56.8	–	–	–	
3375 Cfm	EA (wb)	58	THC	94.8	94.8	106.8	91.3	91.3	102.9	87.5	87.5	98.6	83.4	83.4	94.0	77.9	77.9	87.8
		SHC	82.8	94.8	106.8	79.7	91.3	102.9	76.4	87.5	98.6	72.9	83.4	94.0	68.0	77.9	87.8	
	62	THC	94.8	94.8	110.9	91.4	91.4	106.8	87.6	87.6	102.4	83.5	83.5	97.6	79.3	79.3	92.7	
		SHC	78.8	94.8	110.9	75.9	91.4	106.8	72.8	87.6	102.4	69.3	83.5	97.6	65.9	79.3	92.7	
	67	THC	101.0	101.0	101.0	96.6	96.6	96.6	92.0	92.0	92.0	87.0	87.0	89.6	82.8	82.8	87.3	
		SHC	62.3	78.9	95.4	60.6	77.1	93.7	58.7	75.2	91.7	56.7	73.2	89.6	54.8	71.0	87.3	
	72	THC	108.9	108.9	108.9	104.3	104.3	104.3	99.2	99.2	99.2	93.8	93.8	93.8	86.1	86.1	86.1	
		SHC	45.2	61.7	78.3	43.5	60.0	76.6	41.7	58.2	74.7	39.7	56.2	72.6	37.1	53.6	70.0	
	76	THC	–	115.4	115.4	–	110.4	110.4	–	105.1	105.1	–	99.3	99.3	–	92.2	92.2	
		SHC	–	48.2	65.2	–	46.5	63.4	–	44.7	61.6	–	42.7	59.5	–	40.4	57.1	
3750 Cfm	EA (wb)	58	THC	97.1	97.1	109.5	93.5	93.5	105.4	89.6	89.6	101.0	85.3	85.3	96.1	–	–	–
		SHC	84.8	97.1	109.5	81.7	93.5	105.4	78.2	89.6	101.0	74.5	85.3	96.1	–	–	–	
	62	THC	97.2	97.2	113.7	93.6	93.6	109.5	89.7	89.7	104.8	85.5	85.5	100.0	78.2	78.2	91.4	
		SHC	80.8	97.2	113.7	77.8	93.6	109.5	74.5	89.7	104.8	71.1	85.5	100.0	64.9	78.2	91.4	
	67	THC	102.2	102.2	102.2	97.7	97.7	99.0	93.1	93.1	97.0	88.1	88.1	94.8	–	–	–	
		SHC	64.8	82.8	100.8	63.0	81.0	99.0	61.1	79.1	97.0	59.1	77.0	94.8	–	–	–	
	72	THC	110.1	110.1	110.1	105.3	105.3	105.3	100.2	100.2	100.2	94.7	94.7	94.7	90.0	90.0	90.0	
		SHC	46.1	64.2	82.2	44.4	62.4	80.4	42.6	60.5	78.4	40.7	58.5	76.4	38.9	56.6	74.2	
	76	THC	–	116.5	116.5	–	111.5	111.5	–	106.0	106.0	–	100.1	100.1	–	90.8	90.8	
		SHC	–	49.4	67.8	–	47.7	66.0	–	45.9	64.1	–	43.9	62.0	–	40.8	58.8	

– Not operational

THC – Total Cooling Capacity, Gross (1,000 Btuh)

SHC – Sensible Cooling Capacity, Gross (1,000 Btuh)

# PERFORMANCE DATA (cont.)

CAS091 – FAS120

COMBINATION RATINGS

			AMBIENT TEMPERATURE														
			85			95			105			115			125		
			EA (db)			EA (db)			EA (db)			EA (db)			EA (db)		
			75	80	85	75	80	85	75	80	85	75	80	85	75	80	85
3000 Cfm	58	THC	93.7	93.7	105.5	90.3	90.3	101.8	86.7	86.7	97.7	82.7	82.7	93.2	–	–	–
		SHC	81.8	93.7	105.5	78.9	90.3	101.8	75.7	86.7	97.7	72.2	82.7	93.2	–	–	–
	62	THC	94.5	94.5	106.5	90.8	90.8	104.2	86.8	86.8	101.5	83.0	83.0	97.0	78.0	78.0	91.2
		SHC	76.4	91.4	106.5	74.4	89.3	104.2	72.1	86.8	101.5	68.9	83.0	97.0	64.8	78.0	91.2
	67	THC	101.3	101.3	101.3	97.0	97.0	97.0	92.4	92.4	92.4	87.7	87.7	87.7	80.4	80.4	83.5
		SHC	60.9	76.3	91.7	59.2	74.5	89.9	57.3	72.7	88.0	55.4	70.7	86.0	52.7	68.1	83.5
72	THC	109.4	109.4	109.4	104.9	104.9	104.9	100.0	100.0	100.0	94.7	94.7	94.7	87.1	87.1	87.1	
	SHC	44.9	60.4	75.8	43.3	58.7	74.1	41.5	56.9	72.2	39.6	54.9	70.2	36.9	52.2	67.6	
76	THC	–	116.1	116.1	–	111.3	111.3	–	106.1	106.1	–	100.4	100.4	–	–	–	
	SHC	–	47.7	63.5	–	46.0	61.8	–	44.3	60.0	–	42.3	57.9	–	–	–	
3500 Cfm	58	THC	97.4	97.4	109.7	93.9	93.9	105.8	90.0	90.0	101.4	85.9	85.9	96.8	79.7	79.7	89.8
		SHC	85.0	97.4	109.7	82.0	93.9	105.8	78.6	90.0	101.4	75.0	85.9	96.8	69.6	79.7	89.8
	62	THC	97.5	97.5	114.0	93.9	93.9	109.9	90.1	90.1	105.4	86.0	86.0	100.5	82.6	82.6	96.6
		SHC	81.0	97.5	114.0	78.0	93.9	109.9	74.8	90.1	105.4	71.4	86.0	100.5	68.6	82.6	96.6
	67	THC	103.2	103.2	103.2	98.8	98.8	98.8	94.2	94.2	95.8	89.1	89.1	93.7	82.7	82.7	91.4
		SHC	64.5	82.1	99.6	62.8	80.3	97.8	60.9	78.4	95.8	58.9	76.3	93.7	56.5	73.9	91.4
72	THC	111.2	111.2	111.2	106.6	106.6	106.6	101.6	101.6	101.6	96.2	96.2	96.2	88.8	88.8	88.8	
	SHC	46.3	63.9	81.4	44.7	62.2	79.7	42.9	60.3	77.8	40.9	58.3	75.8	38.4	55.8	73.2	
76	THC	–	117.9	117.9	–	113.0	113.0	–	107.6	107.6	–	101.8	101.8	–	–	–	
	SHC	–	49.5	67.4	–	47.8	65.6	–	46.0	63.7	–	44.0	61.6	–	–	–	
4000 Cfm	58	THC	100.4	100.4	113.1	96.7	96.7	109.0	92.7	92.7	104.5	88.4	88.4	99.6	82.0	82.0	92.4
		SHC	87.7	100.4	113.1	84.4	96.7	109.0	80.9	92.7	104.5	77.2	88.4	99.6	71.6	82.0	92.4
	62	THC	100.4	100.4	117.4	96.8	96.8	113.2	92.8	92.8	108.5	88.4	88.4	103.4	81.7	81.7	95.5
		SHC	83.4	100.4	117.4	80.4	96.8	113.2	77.1	92.8	108.5	73.5	88.4	103.4	67.8	81.7	95.5
	67	THC	104.7	104.7	107.0	100.3	100.3	105.1	95.5	95.5	103.1	90.4	90.4	100.8	82.8	82.8	94.5
		SHC	67.9	87.5	107.0	66.1	85.6	105.1	64.2	83.6	103.1	62.2	81.5	100.8	54.7	74.6	94.5
72	THC	112.7	112.7	112.7	108.0	108.0	108.0	102.8	102.8	102.8	97.3	97.3	97.3	89.9	89.9	89.9	
	SHC	47.7	67.2	86.7	46.0	65.5	84.9	44.1	63.6	83.0	42.2	61.6	80.9	39.7	59.0	78.4	
76	THC	–	119.4	119.4	–	114.3	114.3	–	108.7	108.7	–	103.0	103.0	–	94.3	94.3	
	SHC	–	51.2	71.0	–	49.5	69.2	–	47.6	67.2	–	45.6	65.1	–	42.8	62.0	
4500 Cfm	58	THC	102.7	102.7	115.7	98.9	98.9	111.5	94.8	94.8	106.8	90.3	90.3	101.7	85.1	85.1	95.9
		SHC	89.7	102.7	115.7	86.3	98.9	111.5	82.7	94.8	106.8	78.9	90.3	101.7	74.3	85.1	95.9
	62	THC	102.8	102.8	120.2	99.0	99.0	115.7	94.8	94.8	110.9	90.3	90.3	105.6	83.6	83.6	97.8
		SHC	85.4	102.8	120.2	82.2	99.0	115.7	78.8	94.8	110.9	75.1	90.3	105.6	69.5	83.6	97.8
	67	THC	105.9	105.9	113.8	101.5	101.5	111.7	96.7	96.7	109.5	91.6	91.6	106.8	84.0	84.0	100.0
		SHC	71.0	92.4	113.8	69.2	90.5	111.7	67.2	88.3	109.5	65.0	85.9	106.8	57.0	76.0	100.0
72	THC	113.8	113.8	113.8	109.0	109.0	109.0	103.7	103.7	103.7	98.1	98.1	98.1	89.5	89.5	89.5	
	SHC	48.9	70.3	91.7	47.2	68.6	89.9	45.3	66.6	87.9	43.4	64.6	85.7	40.6	61.8	83.1	
76	THC	–	120.4	120.4	–	115.3	115.3	–	109.6	109.6	–	103.9	103.9	–	–	–	
	SHC	–	52.7	74.3	–	51.0	72.4	–	49.1	70.3	–	47.1	68.1	–	–	–	
5000 Cfm	58	THC	105.0	105.0	118.3	101.0	101.0	113.9	96.8	96.8	109.0	92.1	92.1	103.8	88.1	88.1	99.3
		SHC	91.7	105.0	118.3	88.2	101.0	113.9	84.5	96.8	109.0	80.5	92.1	103.8	76.9	88.1	99.3
	62	THC	105.1	105.1	122.9	101.1	101.1	118.2	96.8	96.8	113.2	92.2	92.2	107.8	85.5	85.5	100.0
		SHC	87.3	105.1	122.9	84.0	101.1	118.2	80.4	96.8	113.2	76.6	92.2	107.8	71.1	85.5	100.0
	67	THC	107.1	107.1	120.5	102.6	102.6	118.3	97.8	97.8	115.8	92.7	92.7	112.8	–	–	–
		SHC	74.1	97.3	120.5	72.2	95.3	118.3	70.1	93.0	115.8	67.8	90.3	112.8	–	–	–
72	THC	114.9	114.9	114.9	109.9	109.9	109.9	104.6	104.6	104.6	98.9	98.9	98.9	–	–	–	
	SHC	50.1	73.4	96.7	48.4	71.6	94.8	46.5	69.6	92.7	44.6	67.5	90.5	–	–	–	
76	THC	–	121.4	121.4	–	116.2	116.2	–	110.4	110.4	–	104.7	104.7	–	–	–	
	SHC	–	54.2	77.5	–	52.4	75.6	–	50.5	73.4	–	48.5	71.1	–	–	–	

– Not operational

THC – Total Cooling Capacity, Gross (1,000 Btuh)

SHC – Sensible Cooling Capacity, Gross (1,000 Btuh)



# PERFORMANCE DATA (cont.)

CAS121 – FAS120

COMBINATION RATINGS

			AMBIENT TEMPERATURE														
			85			95			105			115			125		
			EA (db)			EA (db)			EA (db)			EA (db)			EA (db)		
			75	80	85	75	80	85	75	80	85	75	80	85	75	80	85
3000 Cfm	58	THC	110.5	110.5	121.5	106.2	106.2	117.1	101.6	101.6	112.4	96.9	96.9	107.5	92.5	92.5	102.9
		SHC	99.4	110.5	121.5	95.3	106.2	117.1	90.9	101.6	112.4	86.3	96.9	107.5	82.0	92.5	102.9
	62	THC	114.0	114.0	114.0	108.8	108.8	111.4	103.3	103.3	108.7	97.6	97.6	105.6	91.2	91.2	101.6
		SHC	92.3	103.2	114.0	89.9	100.6	111.4	87.3	98.0	108.7	84.5	95.1	105.6	80.8	91.2	101.6
	67	THC	123.2	123.2	123.2	117.4	117.4	117.4	111.5	111.5	111.5	105.1	105.1	105.1	–	–	–
		SHC	76.4	86.8	97.2	74.1	84.4	94.7	71.7	81.9	92.1	69.1	79.3	89.4	–	–	–
	72	THC	133.0	133.0	133.0	126.8	126.8	126.8	120.4	120.4	120.4	113.5	113.5	113.5	106.0	106.0	106.0
		SHC	60.2	70.1	79.9	57.9	67.7	77.5	55.6	65.3	74.9	53.2	62.7	72.3	50.5	60.0	69.4
	76	THC	–	140.7	140.7	–	134.2	134.2	–	127.6	127.6	–	120.2	120.2	–	112.3	112.3
		SHC	–	56.4	65.8	–	54.1	63.4	–	51.8	61.0	–	49.3	58.4	–	46.6	55.6
3500 Cfm	58	THC	115.8	115.8	128.4	111.2	111.2	123.6	106.3	106.3	118.6	101.1	101.1	113.2	94.3	94.3	106.2
		SHC	103.3	115.8	128.4	98.8	111.2	123.6	94.1	106.3	118.6	89.0	101.1	113.2	82.5	94.3	106.2
	62	THC	117.4	117.4	124.5	112.0	112.0	121.6	106.6	106.6	118.3	101.1	101.1	113.2	93.0	93.0	104.8
		SHC	99.5	112.0	124.5	96.9	109.2	121.6	93.8	106.0	118.3	89.0	101.1	113.2	81.2	93.0	104.8
	67	THC	126.1	126.1	126.1	120.0	120.0	120.0	113.8	113.8	113.8	107.2	107.2	107.2	101.0	101.0	101.0
		SHC	81.5	93.4	105.4	79.1	91.0	102.8	76.7	88.4	100.2	74.1	85.8	97.4	71.6	83.2	94.7
	72	THC	135.6	135.6	135.6	129.2	129.2	129.2	122.6	122.6	122.6	115.5	115.5	115.5	108.0	108.0	108.0
		SHC	62.8	74.1	85.4	60.5	71.7	82.9	58.2	69.3	80.4	55.7	66.7	77.7	53.2	64.0	74.9
	76	THC	–	143.2	143.2	–	136.5	136.5	–	129.7	129.7	–	122.1	122.1	–	–	–
		SHC	–	58.4	69.2	–	56.1	66.8	–	53.8	64.4	–	51.3	61.8	–	–	–
4000 Cfm	58	THC	120.2	120.2	134.3	115.3	115.3	129.2	110.1	110.1	123.8	104.5	104.5	118.0	97.1	97.1	110.4
		SHC	106.1	120.2	134.3	101.4	115.3	129.2	96.4	110.1	123.8	91.0	104.5	118.0	83.9	97.1	110.4
	62	THC	120.5	120.5	133.7	115.3	115.3	129.2	110.2	110.2	123.9	104.6	104.6	118.1	97.0	97.0	110.3
		SHC	105.6	119.7	133.7	101.4	115.3	129.2	96.5	110.2	123.9	91.1	104.6	118.1	83.8	97.0	110.3
	67	THC	128.2	128.2	128.2	122.0	122.0	122.0	115.6	115.6	115.6	108.8	108.8	108.8	101.3	101.3	102.0
		SHC	86.2	99.7	113.2	83.9	97.2	110.6	81.4	94.7	108.0	78.8	92.0	105.1	76.0	89.0	102.0
	72	THC	137.6	137.6	137.6	131.0	131.0	131.0	124.2	124.2	124.2	116.9	116.9	116.9	109.3	109.3	109.3
		SHC	65.2	78.0	90.7	62.9	75.6	88.2	60.6	73.1	85.7	58.1	70.6	83.0	55.6	67.8	80.1
	76	THC	–	145.0	145.0	–	138.2	138.2	–	131.2	131.2	–	–	–	–	–	–
		SHC	–	60.3	72.5	–	58.1	70.1	–	55.8	67.7	–	–	–	–	–	–
4500 Cfm	58	THC	123.8	123.8	139.3	118.6	118.6	134.0	113.2	113.2	128.4	107.3	107.3	122.2	102.3	102.3	117.1
		SHC	108.2	123.8	139.3	103.2	118.6	134.0	98.0	113.2	128.4	92.4	107.3	122.2	87.6	102.3	117.1
	62	THC	123.9	123.9	139.4	118.7	118.7	134.1	113.3	113.3	128.4	107.4	107.4	122.3	101.8	101.8	116.5
		SHC	108.3	123.9	139.4	103.3	118.7	134.1	98.1	113.3	128.4	92.5	107.4	122.3	87.1	101.8	116.5
	67	THC	130.0	130.0	130.0	123.6	123.6	123.6	117.1	117.1	117.1	110.2	110.2	112.5	102.8	102.8	109.3
		SHC	90.8	105.8	120.9	88.3	103.2	118.2	85.8	100.6	115.4	83.2	97.8	112.5	80.3	94.8	109.3
	72	THC	139.1	139.1	139.1	132.4	132.4	132.4	125.5	125.5	125.5	118.1	118.1	118.1	110.3	110.3	110.3
		SHC	67.4	81.7	95.9	65.2	79.3	93.3	62.9	76.8	90.8	60.4	74.2	88.1	57.8	71.5	85.2
	76	THC	–	146.4	146.4	–	139.6	139.6	–	–	–	–	–	–	–	–	–
		SHC	–	62.2	75.7	–	59.9	73.3	–	–	–	–	–	–	–	–	–
5000 Cfm	58	THC	126.8	126.8	143.8	121.4	121.4	138.2	115.8	115.8	132.3	109.8	109.8	126.1	103.0	103.0	119.1
		SHC	109.8	126.8	143.8	104.5	121.4	138.2	99.2	115.8	132.3	93.4	109.8	126.1	86.9	103.0	119.1
	62	THC	126.9	126.9	143.9	121.4	121.4	138.2	115.9	115.9	132.4	109.8	109.8	126.2	103.1	103.1	119.2
		SHC	109.8	126.9	143.9	104.6	121.4	138.2	99.3	115.9	132.4	93.5	109.8	126.2	87.0	103.1	119.2
	67	THC	131.4	131.4	131.4	125.0	125.0	125.5	118.4	118.4	122.7	111.5	111.5	119.6	104.1	104.1	116.1
		SHC	95.1	111.7	128.2	92.6	109.1	125.5	90.1	106.4	122.7	87.3	103.4	119.6	84.2	100.1	116.1
	72	THC	140.3	140.3	140.3	133.5	133.5	133.5	126.6	126.6	126.6	119.0	119.0	119.0	111.1	111.1	111.1
		SHC	69.6	85.3	100.9	67.4	82.9	98.4	65.1	80.5	95.9	62.6	77.9	93.2	60.0	75.1	90.3
	76	THC	–	147.6	147.6	–	–	–	–	–	–	–	–	–	–	–	–
		SHC	–	64.0	78.8	–	–	–	–	–	–	–	–	–	–	–	–

– Not operational

THC – Total Cooling Capacity, Gross (1,000 Btuh)

SHC – Sensible Cooling Capacity, Gross (1,000 Btuh)

# PERFORMANCE DATA (cont.)

CAS121 – FAS150

COMBINATION RATINGS

			AMBIENT TEMPERATURE															
			85			95			105			115			125			
			EA (db)			EA (db)			EA (db)			EA (db)			EA (db)			
			75	80	85	75	80	85	75	80	85	75	80	85	75	80	85	
3750 Cfm	EA (wb)	58	THC	119.7	119.7	132.9	115.2	115.2	128.3	110.5	110.5	123.4	105.3	105.3	118.0	97.9	97.9	110.4
			SHC	106.5	119.7	132.9	102.2	115.2	128.3	97.6	110.5	123.4	92.6	105.3	118.0	85.5	97.9	110.4
		62	THC	121.2	121.2	130.3	116.0	116.0	127.0	110.8	110.8	122.9	105.4	105.4	118.1	98.7	98.7	111.1
			SHC	104.0	117.2	130.3	101.0	114.0	127.0	97.2	110.1	122.9	92.7	105.4	118.1	86.2	98.7	111.1
		67	THC	130.0	130.0	130.0	124.4	124.4	124.4	118.5	118.5	118.5	112.0	112.0	112.0	104.9	104.9	104.9
		SHC	85.3	97.8	110.3	83.1	95.5	108.0	80.8	93.1	105.5	78.3	90.5	102.7	75.6	87.7	99.8	
	72	THC	139.4	139.4	139.4	133.7	133.7	133.7	127.7	127.7	127.7	120.9	120.9	120.9	113.5	113.5	113.5	
		SHC	65.3	77.1	88.8	63.3	75.0	86.7	61.2	72.8	84.4	58.9	70.4	81.8	56.3	67.7	79.0	
		76	THC	–	–	–	–	–	–	–	–	–	–	–	–	–	–	–
			SHC	–	–	–	–	–	–	–	–	–	–	–	–	–	–	–
4300 Cfm	EA (wb)	58	THC	124.1	124.1	138.8	119.4	119.4	134.1	114.5	114.5	128.9	109.0	109.0	123.2	100.5	100.5	114.4
			SHC	109.2	124.1	138.8	104.8	119.4	134.1	100.0	114.5	128.9	94.8	109.0	123.2	86.6	100.5	114.4
		62	THC	124.5	124.5	138.3	119.5	119.5	134.1	114.5	114.5	128.9	109.1	109.1	123.3	101.0	101.0	114.9
			SHC	108.7	123.5	138.3	104.9	119.5	134.1	100.1	114.5	128.9	94.9	109.1	123.3	87.1	101.0	114.9
		67	THC	132.1	132.1	132.1	126.4	126.4	126.4	120.4	120.4	121.1	113.8	113.8	115.6	106.5	106.5	109.5
		SHC	90.7	104.9	119.0	88.5	102.5	116.6	86.1	100.1	114.1	83.6	97.4	111.2	80.7	94.5	108.1	
	72	THC	141.3	141.3	141.3	135.5	135.5	135.5	129.5	129.5	129.5	122.6	122.6	122.6	114.3	114.3	114.3	
		SHC	68.1	81.4	94.7	66.1	79.3	92.6	64.0	77.1	90.3	61.7	74.7	87.7	57.6	69.7	81.7	
		76	THC	–	–	–	–	–	–	–	–	–	–	–	–	–	–	–
			SHC	–	–	–	–	–	–	–	–	–	–	–	–	–	–	–
5000 Cfm	EA (wb)	58	THC	128.9	128.9	145.7	124.1	124.1	140.7	118.9	118.9	135.3	113.2	113.2	129.3	106.8	106.8	122.7
			SHC	112.1	128.9	145.7	107.5	124.1	140.7	102.5	118.9	135.3	97.0	113.2	129.3	90.9	106.8	122.7
		62	THC	129.0	129.0	145.8	124.2	124.2	140.7	119.0	119.0	135.3	113.3	113.3	129.4	106.8	106.8	122.7
			SHC	112.2	129.0	145.8	107.6	124.2	140.7	102.6	119.0	135.3	97.1	113.3	129.4	91.0	106.8	122.7
		67	THC	134.4	134.4	134.4	128.6	128.6	128.6	122.5	122.5	124.7	115.8	115.8	121.8	108.4	108.4	118.5
		SHC	97.3	113.6	129.8	95.1	111.2	127.4	92.7	108.7	124.7	90.1	105.9	121.8	87.0	102.8	118.5	
	72	THC	143.4	143.4	143.4	137.5	137.5	137.5	131.3	131.3	131.3	124.3	124.3	124.3	–	–	–	
		SHC	71.6	86.8	102.0	69.6	84.7	99.9	67.5	82.6	97.6	65.2	80.1	95.0	–	–	–	
		76	THC	–	–	–	–	–	–	–	–	–	–	–	–	–	–	–
			SHC	–	–	–	–	–	–	–	–	–	–	–	–	–	–	–
5700 Cfm	EA (wb)	58	THC	132.3	132.3	151.0	127.3	127.3	145.8	122.0	122.0	140.3	116.1	116.1	134.1	109.5	109.5	127.2
			SHC	113.6	132.3	151.0	108.8	127.3	145.8	103.7	122.0	140.3	98.1	116.1	134.1	91.8	109.5	127.2
		62	THC	132.4	132.4	151.1	127.4	127.4	145.9	122.1	122.1	140.3	116.2	116.2	134.2	109.5	109.5	127.3
			SHC	113.7	132.4	151.1	108.9	127.4	145.9	103.8	122.1	140.3	98.1	116.2	134.2	91.8	109.5	127.3
		67	THC	136.0	136.0	141.8	130.2	130.2	137.7	124.1	124.1	134.2	117.4	117.4	130.6	110.3	110.3	125.5
		SHC	103.2	121.5	139.8	100.8	119.0	137.2	98.1	116.1	134.2	94.9	112.7	130.6	90.2	107.8	125.5	
	72	THC	144.7	144.7	144.7	138.8	138.8	138.8	132.0	132.0	140.6	126.0	126.0	133.0	–	–	–	
		SHC	74.8	92.0	109.1	72.8	89.9	107.0	71.4	88.0	81.8	68.7	85.2	101.8	–	–	–	
		76	THC	–	–	–	–	–	–	–	–	–	–	–	–	–	–	–
			SHC	–	–	–	–	–	–	–	–	–	–	–	–	–	–	–
6250 Cfm	EA (wb)	58	THC	134.9	134.9	155.1	129.8	129.8	149.8	124.4	124.4	144.2	118.3	118.3	137.8	111.6	111.6	130.8
			SHC	114.7	134.9	155.1	109.9	129.8	149.8	104.7	124.4	144.2	98.9	118.3	137.8	92.5	111.6	130.8
		62	THC	135.0	135.0	155.2	129.9	129.9	149.9	124.5	124.5	144.2	118.4	118.4	137.9	111.7	111.7	130.9
			SHC	114.8	135.0	155.2	109.9	129.9	149.9	104.7	124.5	144.2	98.9	118.4	137.9	92.5	111.7	130.9
		67	THC	137.2	137.2	147.6	131.4	131.4	144.9	125.3	125.3	141.6	118.7	118.7	137.5	111.8	111.8	131.0
		SHC	107.8	127.7	147.6	105.3	125.1	144.9	102.4	122.0	141.6	98.6	118.1	137.5	92.7	111.8	131.0	
	72	THC	145.7	145.7	145.7	139.9	139.9	139.9	–	–	–	–	–	–	–	–	–	
		SHC	77.3	96.0	114.7	75.4	94.0	112.6	–	–	–	–	–	–	–	–	–	
		76	THC	–	–	–	–	–	–	–	–	–	–	–	–	–	–	–
			SHC	–	–	–	–	–	–	–	–	–	–	–	–	–	–	–

– Not operational

THC – Total Cooling Capacity, Gross (1,000 Btuh)

SHC – Sensible Cooling Capacity, Gross (1,000 Btuh)

# PERFORMANCE DATA (cont.)

CAS120 – FAS120

COMBINATION RATINGS

			AMBIENT TEMPERATURE														
			85			95			105			115			125		
			EA (db)			EA (db)			EA (db)			EA (db)			EA (db)		
			75	80	85	75	80	85	75	80	85	75	80	85	75	80	85
3000 Cfm	58	THC	111.6	111.6	125.3	107.3	107.3	120.5	102.6	102.6	115.2	97.3	97.3	109.4	91.7	91.7	103.0
		SHC	97.9	111.6	125.3	94.1	107.3	120.5	89.9	102.6	115.2	85.3	97.3	109.4	80.3	91.7	103.0
	62	THC	115.9	115.9	119.8	110.5	110.5	117.1	104.8	104.8	114.2	98.3	98.3	110.7	92.4	92.4	106.2
		SHC	88.6	104.2	119.8	86.0	101.5	117.1	83.2	98.7	114.2	79.9	95.3	110.7	76.2	91.2	106.2
	67	THC	125.6	125.6	125.6	119.9	119.9	119.9	113.7	113.7	113.7	107.1	107.1	107.1	99.6	99.6	99.6
		SHC	71.9	87.6	103.3	69.4	85.1	100.8	66.8	82.5	98.1	63.9	79.6	95.3	60.8	76.5	92.2
	72	THC	135.6	135.6	135.6	129.6	129.6	129.6	123.1	123.1	123.1	116.1	116.1	116.1	108.4	108.4	108.4
		SHC	55.0	70.8	86.6	52.6	68.4	84.2	50.1	65.9	81.7	47.4	63.2	79.0	44.5	60.3	76.1
	76	THC	–	143.6	143.6	–	137.4	137.4	–	130.7	130.7	–	123.3	123.3	–	115.2	115.2
		SHC	–	57.3	73.6	–	55.1	71.4	–	52.7	68.9	–	50.1	66.2	–	47.4	63.4
3500 Cfm	58	THC	117.1	117.1	131.6	112.5	112.5	126.4	107.5	107.5	120.8	102.0	102.0	114.7	95.7	95.7	107.7
		SHC	102.6	117.1	131.6	98.6	112.5	126.4	94.2	107.5	120.8	89.4	102.0	114.7	83.8	95.7	107.7
	62	THC	119.3	119.3	130.8	113.8	113.8	127.8	108.1	108.1	123.7	102.1	102.1	119.1	95.7	95.7	111.7
		SHC	95.1	112.9	130.8	92.3	110.0	127.8	88.9	106.3	123.7	85.1	102.1	119.1	79.7	95.7	111.7
	67	THC	128.8	128.8	128.8	122.8	122.8	122.8	116.4	116.4	116.4	109.5	109.5	109.5	101.9	101.9	101.9
		SHC	76.0	94.1	112.2	73.5	91.6	109.7	70.8	88.9	107.0	68.0	86.1	104.2	64.9	82.9	101.0
	72	THC	138.6	138.6	138.6	132.5	132.5	132.5	125.8	125.8	125.8	118.4	118.4	118.4	110.5	110.5	110.5
		SHC	56.5	74.8	93.0	54.2	72.4	90.6	51.7	69.9	88.1	48.9	67.1	85.3	46.0	64.2	82.4
	76	THC	–	146.6	146.6	–	140.2	140.2	–	133.2	133.2	–	125.6	125.6	–	–	–
		SHC	–	59.4	78.0	–	57.1	75.7	–	54.7	73.3	–	52.2	70.6	–	–	–
4000 Cfm	58	THC	121.6	121.6	136.6	116.7	116.7	131.2	111.4	111.4	125.3	105.7	105.7	118.9	99.2	99.2	111.7
		SHC	106.5	121.6	136.6	102.2	116.7	131.2	97.6	111.4	125.3	92.5	105.7	118.9	86.8	99.2	111.7
	62	THC	122.2	122.2	140.3	117.0	117.0	135.6	111.4	111.4	130.0	105.7	105.7	123.4	99.2	99.2	115.9
		SHC	100.7	120.5	140.3	97.0	116.3	135.6	92.8	111.4	130.0	88.0	105.7	123.4	82.6	99.2	115.9
	67	THC	131.1	131.1	131.1	125.0	125.0	125.0	118.5	118.5	118.5	111.4	111.4	112.6	103.7	103.7	109.4
		SHC	79.9	100.4	120.8	77.4	97.8	118.3	74.7	95.1	115.6	71.8	92.2	112.6	68.7	89.0	109.4
	72	THC	140.9	140.9	140.9	134.6	134.6	134.6	127.7	127.7	127.7	120.3	120.3	120.3	112.1	112.1	112.1
		SHC	57.9	78.6	99.2	55.6	76.2	96.8	53.1	73.7	94.2	50.4	70.9	91.5	47.5	68.0	88.5
	76	THC	–	148.8	148.8	–	142.3	142.3	–	135.2	135.2	–	–	–	–	–	–
		SHC	–	61.3	82.2	–	59.1	80.0	–	56.7	77.5	–	–	–	–	–	–
4500 Cfm	58	THC	125.3	125.3	140.9	120.2	120.2	135.3	114.8	114.8	129.1	108.8	108.8	122.4	102.4	102.4	115.2
		SHC	109.7	125.3	140.9	105.2	120.2	135.3	100.4	114.8	129.1	95.2	108.8	122.4	89.5	102.4	115.2
	62	THC	125.3	125.3	146.2	120.2	120.2	140.3	114.7	114.7	134.0	108.8	108.8	127.1	102.4	102.4	119.6
		SHC	104.4	125.3	146.2	100.1	120.2	140.3	95.5	114.7	134.0	90.5	108.8	127.1	85.1	102.4	119.6
	67	THC	133.0	133.0	133.0	126.8	126.8	126.8	120.1	120.1	123.8	112.9	112.9	120.7	105.1	105.1	117.3
		SHC	83.6	106.4	129.2	81.1	103.8	126.6	78.3	101.0	123.8	75.4	98.0	120.7	72.2	94.8	117.3
	72	THC	142.8	142.8	142.8	136.3	136.3	136.3	129.3	129.3	129.3	121.7	121.7	121.7	113.3	113.3	113.3
		SHC	59.3	82.2	105.1	57.0	79.9	102.8	54.4	77.3	100.2	51.7	74.6	97.5	48.8	71.6	94.5
	76	THC	–	150.5	150.5	–	143.9	143.9	–	–	–	–	–	–	–	–	–
		SHC	–	63.1	86.4	–	60.9	84.1	–	–	–	–	–	–	–	–	–
5000 Cfm	58	THC	128.4	128.4	144.5	123.2	123.2	138.7	117.6	117.6	132.3	111.4	111.4	125.4	104.7	104.7	117.9
		SHC	112.4	128.4	144.5	107.8	123.2	138.7	102.8	117.6	132.3	97.4	111.4	125.4	91.5	104.7	117.9
	62	THC	128.4	128.4	149.9	123.2	123.2	143.9	117.5	117.5	137.3	111.4	111.4	130.2	104.7	104.7	122.4
		SHC	106.9	128.4	149.9	102.5	123.2	143.9	97.8	117.5	137.3	92.6	111.4	130.2	87.0	104.7	122.4
	67	THC	134.6	134.6	137.2	128.3	128.3	134.5	121.5	121.5	131.6	114.2	114.2	128.3	106.3	106.3	124.6
		SHC	87.1	112.2	137.2	84.6	109.5	134.5	81.8	106.7	131.6	78.8	103.6	128.3	75.5	100.1	124.6
	72	THC	144.2	144.2	144.2	137.7	137.7	137.7	130.6	130.6	130.6	122.8	122.8	122.8	114.4	114.4	114.4
		SHC	60.6	85.8	111.0	58.3	83.5	108.6	55.8	80.9	106.1	53.0	78.2	103.3	50.1	75.2	100.3
	76	THC	–	151.9	151.9	–	–	–	–	–	–	–	–	–	–	–	–
		SHC	–	64.9	90.4	–	–	–	–	–	–	–	–	–	–	–	–

– Not operational

THC – Total Cooling Capacity, Gross (1,000 Btuh)

SHC – Sensible Cooling Capacity, Gross (1,000 Btuh)

# PERFORMANCE DATA (cont.)

CAS120 – FAS150

COMBINATION RATINGS

			AMBIENT TEMPERATURE														
			85			95			105			115			125		
			EA (db)			EA (db)			EA (db)			EA (db)			EA (db)		
			75	80	85	75	80	85	75	80	85	75	80	85	75	80	85
3750 Cfm	58	THC	118.1	118.1	133.1	113.8	113.8	128.3	109.1	109.1	123.0	103.9	103.9	117.1	98.2	98.2	110.7
		SHC	103.1	118.1	133.1	99.4	113.8	128.3	95.3	109.1	123.0	90.7	103.9	117.1	85.8	98.2	110.7
	62	THC	120.1	120.1	133.8	115.0	115.0	130.9	109.5	109.5	127.1	104.1	104.1	121.7	98.3	98.3	115.0
		SHC	96.2	115.0	133.8	93.6	112.3	130.9	90.5	108.8	127.1	86.4	104.1	121.7	81.7	98.3	115.0
	67	THC	130.2	130.2	130.2	124.8	124.8	124.8	118.7	118.7	118.7	112.0	112.0	112.0	104.6	104.6	105.5
		SHC	77.7	96.9	116.0	75.5	94.6	113.8	73.0	92.2	111.3	70.4	89.5	108.6	67.4	86.4	105.5
72	THC	140.9	140.9	140.9	135.4	135.4	135.4	129.2	129.2	129.2	122.3	122.3	122.3	114.6	114.6	114.6	
	SHC	58.0	77.3	96.6	56.0	75.3	94.5	53.7	73.0	92.2	51.2	70.4	89.7	48.4	67.6	86.8	
76	THC	–	149.8	149.8	–	144.2	144.2	–	137.8	137.8	–	130.6	130.6	–	122.6	122.6	
	SHC	–	61.4	81.1	–	59.4	79.1	–	57.3	76.9	–	54.9	74.5	–	52.2	71.7	
4300 Cfm	58	THC	122.7	122.7	138.2	118.2	118.2	133.2	113.3	113.3	127.7	107.9	107.9	121.5	101.8	101.8	114.7
		SHC	107.1	122.7	138.2	103.3	118.2	133.2	98.9	113.3	127.7	94.1	107.9	121.5	88.9	101.8	114.7
	62	THC	123.2	123.2	142.6	118.4	118.4	138.1	113.4	113.4	132.5	108.0	108.0	126.2	101.9	101.9	119.1
		SHC	101.5	122.0	142.6	98.2	118.1	138.1	94.1	113.3	132.5	89.7	108.0	126.2	84.6	101.9	119.1
	67	THC	132.3	132.3	132.3	126.8	126.8	126.8	120.6	120.6	121.3	113.8	113.8	118.1	106.3	106.3	114.4
		SHC	81.8	103.6	125.2	79.6	101.3	123.0	77.1	98.8	120.5	74.4	96.0	117.7	71.4	92.9	114.4
72	THC	143.1	143.1	143.1	137.4	137.4	137.4	131.0	131.0	131.0	124.0	124.0	124.0	116.1	116.1	116.1	
	SHC	59.7	81.4	103.3	57.7	79.4	101.2	55.4	77.1	98.9	52.9	74.6	96.3	50.1	71.8	93.5	
76	THC	–	–	–	–	–	–	–	–	–	–	–	–	–	–	–	
	SHC	–	–	–	–	–	–	–	–	–	–	–	–	–	–	–	
5000 Cfm	58	THC	127.4	127.4	143.6	122.8	122.8	138.4	117.7	117.7	132.6	111.9	111.9	126.1	105.5	105.5	118.9
		SHC	111.3	127.4	143.6	107.2	122.8	138.4	102.7	117.7	132.6	97.7	111.9	126.1	92.1	105.5	118.9
	62	THC	127.5	127.5	149.1	122.9	122.9	143.7	117.7	117.7	137.7	112.0	112.0	131.0	105.6	105.6	123.5
		SHC	105.9	127.5	149.1	102.1	122.9	143.7	97.8	117.7	137.7	93.0	112.0	131.0	87.7	105.6	123.5
	67	THC	134.4	134.4	136.4	128.9	128.9	134.1	122.6	122.6	131.4	115.7	115.7	128.4	108.0	108.0	124.8
		SHC	86.9	111.7	136.4	84.7	109.4	134.1	82.2	106.8	131.4	79.3	103.8	128.4	76.2	100.5	124.8
72	THC	145.1	145.1	145.1	139.4	139.4	139.4	132.9	132.9	132.9	125.7	125.7	125.7	117.6	117.6	117.6	
	SHC	61.7	86.6	111.5	59.6	84.6	109.5	57.4	82.3	107.2	54.8	79.7	104.6	52.1	76.9	101.7	
76	THC	–	–	–	–	–	–	–	–	–	–	–	–	–	–	–	
	SHC	–	–	–	–	–	–	–	–	–	–	–	–	–	–	–	
5700 Cfm	58	THC	131.2	131.2	147.9	126.4	126.4	142.4	121.1	121.1	136.4	115.1	115.1	129.8	108.5	108.5	122.4
		SHC	114.5	131.2	147.9	110.3	126.4	142.4	105.7	121.1	136.4	100.5	115.1	129.8	94.8	108.5	122.4
	62	THC	131.3	131.3	153.5	126.5	126.5	148.0	121.2	121.2	141.7	115.2	115.2	134.7	108.6	108.6	127.1
		SHC	109.0	131.3	153.5	105.1	126.5	148.0	100.6	121.2	141.7	95.7	115.2	134.7	90.3	108.6	127.1
	67	THC	136.1	136.1	146.9	130.5	130.5	144.4	124.2	124.2	141.6	117.2	117.2	138.0	109.6	109.6	133.8
		SHC	91.6	119.3	146.9	89.3	116.9	144.4	86.7	114.2	141.6	83.8	111.0	138.0	80.2	107.0	133.8
72	THC	146.6	146.6	146.6	140.9	140.9	140.9	134.2	134.2	134.2	126.9	126.9	126.9	118.7	118.7	118.7	
	SHC	63.5	91.5	119.6	61.5	89.5	117.5	59.3	87.2	115.2	56.7	84.6	112.6	54.0	81.8	109.7	
76	THC	–	–	–	–	–	–	–	–	–	–	–	–	–	–	–	
	SHC	–	–	–	–	–	–	–	–	–	–	–	–	–	–	–	
6250 Cfm	58	THC	133.5	133.5	150.5	128.7	128.7	145.0	123.3	123.3	138.9	117.2	117.2	132.1	110.5	110.5	124.5
		SHC	116.6	133.5	150.5	112.4	128.7	145.0	107.6	123.3	138.9	102.3	117.2	132.1	96.4	110.5	124.5
	62	THC	133.6	133.6	156.3	128.8	128.8	150.6	123.3	123.3	144.2	117.3	117.3	137.1	110.5	110.5	129.2
		SHC	111.0	133.6	156.3	107.0	128.8	150.6	102.5	123.3	144.2	97.4	117.3	137.1	91.8	110.5	129.2
	67	THC	137.1	137.1	154.6	131.5	131.5	151.9	125.1	125.1	148.6	118.2	118.2	144.5	110.8	110.8	138.2
		SHC	95.1	124.8	154.6	92.7	122.3	151.9	89.9	119.3	148.6	86.7	115.6	144.5	82.4	110.3	138.2
72	THC	147.5	147.5	147.5	141.7	141.7	141.7	135.0	135.0	135.0	127.6	127.6	127.6	119.4	119.4	119.4	
	SHC	65.0	95.3	125.6	63.0	93.3	123.6	60.7	91.0	121.2	58.2	88.4	118.6	55.4	85.6	115.8	
76	THC	–	–	–	–	–	–	–	–	–	–	–	–	–	–	–	
	SHC	–	–	–	–	–	–	–	–	–	–	–	–	–	–	–	

– Not operational

THC – Total Cooling Capacity, Gross (1,000 Btuh)

SHC – Sensible Cooling Capacity, Gross (1,000 Btuh)

# PERFORMANCE DATA (cont.)

CAS151 – FAS150

COMBINATION RATINGS

			AMBIENT TEMPERATURE														
			85			95			105			115			125		
			EA (db)			EA (db)			EA (db)			EA (db)			EA (db)		
			75	80	85	75	80	85	75	80	85	75	80	85	75	80	85
3750 Cfm	58	THC	138.4	138.4	152.4	133.2	133.2	147.0	127.6	127.6	141.2	121.6	121.6	135.0	113.3	113.3	126.5
		SHC	124.5	138.4	152.4	119.4	133.2	147.0	114.0	127.6	141.2	108.2	121.6	135.0	100.2	113.3	126.5
	62	THC	144.5	144.5	144.5	137.9	137.9	138.9	131.0	131.0	135.4	123.7	123.7	131.6	–	–	–
		SHC	114.9	128.6	142.3	111.8	125.4	138.9	108.6	122.0	135.4	105.0	118.3	131.6	–	–	–
	67	THC	156.4	156.4	156.4	149.4	149.4	149.4	141.9	141.9	141.9	134.0	134.0	134.0	125.3	125.3	125.3
		SHC	95.6	108.7	121.7	92.7	105.7	118.6	89.7	102.5	115.3	86.5	99.2	111.9	83.1	95.7	108.2
	72	THC	168.6	168.6	168.6	161.2	161.2	161.2	153.4	153.4	153.4	144.8	144.8	144.8	135.6	135.6	135.6
		SHC	75.7	88.1	100.4	73.0	85.2	97.5	70.1	82.2	94.3	67.0	79.0	91.0	63.8	75.6	87.4
	76	THC	–	178.5	178.5	–	170.8	170.8	–	162.6	162.6	–	153.6	153.6	–	143.9	143.9
		SHC	–	71.4	83.2	–	68.7	80.3	–	65.8	77.3	–	62.7	74.0	–	59.4	70.6
4375 Cfm	58	THC	145.4	145.4	161.2	139.7	139.7	155.4	133.7	133.7	149.2	127.3	127.3	142.6	121.3	121.3	136.3
		SHC	129.5	145.4	161.2	124.0	139.7	155.4	118.3	133.7	149.2	112.1	127.3	142.6	106.3	121.3	136.3
	62	THC	148.6	148.6	155.2	141.9	141.9	151.6	134.8	134.8	147.6	127.5	127.5	142.8	121.2	121.2	136.1
		SHC	123.8	139.5	155.2	120.5	136.0	151.6	116.8	132.2	147.6	112.3	127.5	142.8	106.1	121.1	136.1
	67	THC	160.2	160.2	160.2	152.9	152.9	152.9	145.2	145.2	145.2	136.9	136.9	136.9	127.9	127.9	127.9
		SHC	101.9	116.9	131.8	99.0	113.8	128.7	96.0	110.7	125.4	92.8	107.3	121.9	89.3	103.7	118.1
	72	THC	172.3	172.3	172.3	164.7	164.7	164.7	156.5	156.5	156.5	147.7	147.7	147.7	138.1	138.1	138.1
		SHC	79.0	93.2	107.3	76.3	90.3	104.3	73.4	87.3	101.1	70.3	84.0	97.8	67.0	80.6	94.2
	76	THC	–	182.1	182.1	–	174.2	174.2	–	165.6	165.6	–	156.4	156.4	–	146.3	146.3
		SHC	–	74.0	87.5	–	71.3	84.6	–	68.4	81.5	–	65.3	78.3	–	61.9	74.8
5000 Cfm	58	THC	151.0	151.0	168.8	145.0	145.0	162.6	138.7	138.7	156.0	131.9	131.9	149.0	124.6	124.6	141.4
		SHC	133.2	151.0	168.8	127.5	145.0	162.6	121.4	138.7	156.0	114.9	131.9	149.0	107.9	124.6	141.4
	62	THC	152.2	152.2	166.8	145.3	145.3	162.8	138.9	138.9	156.2	132.0	132.0	149.1	124.7	124.7	141.5
		SHC	131.5	149.1	166.8	127.8	145.3	162.8	121.5	138.9	156.2	115.0	132.0	149.1	107.9	124.7	141.5
	67	THC	163.1	163.1	163.1	155.6	155.6	155.6	147.6	147.6	147.6	139.1	139.1	139.1	130.1	130.1	130.1
		SHC	107.9	124.8	141.6	105.0	121.7	138.5	101.9	118.5	135.1	98.6	115.1	131.5	95.1	111.4	127.7
	72	THC	175.0	175.0	175.0	167.3	167.3	167.3	158.8	158.8	158.8	149.8	149.8	149.8	140.0	140.0	140.0
		SHC	82.1	98.0	113.9	79.4	95.2	111.0	76.5	92.1	107.8	73.4	88.9	104.4	70.1	85.4	100.7
	76	THC	–	184.8	184.8	–	176.6	176.6	–	167.9	167.9	–	158.4	158.4	–	–	–
		SHC	–	76.5	91.6	–	73.8	88.8	–	70.8	85.7	–	67.7	82.4	–	–	–
5625 Cfm	58	THC	155.6	155.6	175.2	149.4	149.4	168.8	142.8	142.8	161.9	135.7	135.7	154.5	127.9	127.9	146.4
		SHC	136.0	155.6	175.2	130.0	149.4	168.8	123.7	142.8	161.9	116.8	135.7	154.5	109.4	127.9	146.4
	62	THC	155.7	155.7	175.3	149.5	149.5	168.8	142.9	142.9	162.0	135.8	135.8	154.6	128.0	128.0	146.5
		SHC	136.1	155.7	175.3	130.1	149.5	168.8	123.8	142.9	162.0	117.0	135.8	154.6	109.5	128.0	146.5
	67	THC	165.3	165.3	165.3	157.8	157.8	157.8	149.6	149.6	149.6	140.9	140.9	140.9	131.7	131.7	136.8
		SHC	113.6	132.4	151.2	110.7	129.3	148.0	107.5	126.0	144.5	104.1	122.5	140.8	100.5	118.6	136.8
	72	THC	177.3	177.3	177.3	169.3	169.3	169.3	160.7	160.7	160.7	151.5	151.5	151.5	141.6	141.6	141.6
		SHC	85.0	102.7	120.5	82.3	99.9	117.4	79.4	96.8	114.2	76.3	93.6	110.8	73.0	90.1	107.2
	76	THC	–	187.0	187.0	–	178.7	178.7	–	169.7	169.7	–	–	–	–	–	–
		SHC	–	78.9	95.7	–	76.2	92.8	–	73.2	89.8	–	–	–	–	–	–
6250 Cfm	58	THC	159.5	159.5	180.9	153.1	153.1	174.3	146.2	146.2	167.1	138.9	138.9	159.5	131.0	131.0	151.2
		SHC	138.0	159.5	180.9	131.9	153.1	174.3	125.3	146.2	167.1	118.3	138.9	159.5	110.7	131.0	151.2
	62	THC	159.6	159.6	181.0	153.2	153.2	174.4	146.3	146.3	167.2	139.0	139.0	159.5	131.0	131.0	151.2
		SHC	138.2	159.6	181.0	132.0	153.2	174.4	125.5	146.3	167.2	118.4	139.0	159.5	110.7	131.0	151.2
	67	THC	167.2	167.2	167.2	159.5	159.5	159.5	151.2	151.2	153.5	142.5	142.5	149.6	133.1	133.1	145.3
		SHC	119.0	139.7	160.4	116.0	136.6	157.1	112.8	133.1	153.5	109.2	129.4	149.6	105.3	125.3	145.3
	72	THC	179.0	179.0	179.0	170.9	170.9	170.9	162.2	162.2	162.2	152.8	152.8	152.8	142.6	142.6	142.6
		SHC	87.9	107.4	126.8	85.1	104.5	123.8	82.2	101.4	120.6	79.1	98.2	117.2	75.9	94.7	113.5
	76	THC	–	188.7	188.7	–	180.2	180.2	–	–	–	–	–	–	–	–	–
		SHC	–	81.3	99.8	–	78.5	96.9	–	–	–	–	–	–	–	–	–

– Not operational

THC – Total Cooling Capacity, Gross (1,000 Btuh)

SHC – Sensible Cooling Capacity, Gross (1,000 Btuh)

# PERFORMANCE DATA (cont.)

CAS151 – FAS180

COMBINATION RATINGS

			AMBIENT TEMPERATURE														
			85			95			105			115			125		
			EA (db)			EA (db)			EA (db)			EA (db)			EA (db)		
			75	80	85	75	80	85	75	80	85	75	80	85	75	80	85
4500 Cfm	58	THC	149.9	149.9	166.0	144.0	144.0	160.0	137.7	137.7	153.4	130.8	130.8	146.3	122.9	122.9	138.1
		SHC	133.8	149.9	166.0	128.1	144.0	160.0	122.0	137.7	153.4	115.3	130.8	146.3	107.8	122.9	138.1
	62	THC	152.8	152.8	160.5	145.8	145.8	156.7	138.6	138.6	152.1	131.1	131.1	146.5	122.0	122.0	137.1
		SHC	128.7	144.6	160.5	125.2	141.0	156.7	120.8	136.5	152.1	115.6	131.1	146.5	106.8	122.0	137.1
	67	THC	164.6	164.6	164.6	157.1	157.1	157.1	149.0	149.0	149.0	140.3	140.3	140.3	–	–	–
		SHC	105.8	120.9	136.1	102.8	117.8	132.9	99.7	114.5	129.5	96.2	111.0	125.8	–	–	–
	72	THC	176.9	176.9	176.9	169.1	169.1	169.1	160.6	160.6	160.6	151.4	151.4	151.4	–	–	–
		SHC	81.9	96.2	110.5	79.1	93.3	107.5	76.1	90.1	104.2	72.9	86.7	100.7	–	–	–
	76	THC	–	187.1	187.1	–	179.0	179.0	–	169.7	169.7	–	–	–	–	–	–
		SHC	–	76.2	89.7	–	73.4	86.9	–	69.9	82.9	–	–	–	–	–	–
5300 Cfm	58	THC	156.6	156.6	175.0	150.4	150.4	168.6	143.7	143.7	161.7	136.4	136.4	154.1	124.7	124.7	141.2
		SHC	138.2	156.6	175.0	132.2	150.4	168.6	125.8	143.7	161.7	118.8	136.4	154.1	108.2	124.7	141.2
	62	THC	157.6	157.6	173.5	150.7	150.7	168.8	143.8	143.8	161.7	136.5	136.5	154.2	125.1	125.1	141.6
		SHC	136.9	155.2	173.5	132.5	150.7	168.8	125.9	143.8	161.7	118.9	136.5	154.2	108.6	125.1	141.6
	67	THC	167.9	167.9	167.9	160.2	160.2	160.2	151.8	151.8	152.2	142.9	142.9	144.4	–	–	–
		SHC	113.4	131.0	148.5	110.5	127.9	145.3	107.3	124.5	141.7	103.8	120.9	138.0	–	–	–
	72	THC	180.2	180.2	180.2	172.1	172.1	172.1	163.4	163.4	163.4	153.9	153.9	153.9	–	–	–
		SHC	85.9	102.4	118.8	83.1	99.5	115.8	80.1	96.3	112.5	76.9	92.9	109.0	–	–	–
	76	THC	–	189.4	189.4	–	181.2	181.2	–	–	–	–	–	–	–	–	–
		SHC	–	78.2	93.1	–	75.5	90.3	–	–	–	–	–	–	–	–	–
6000 Cfm	58	THC	161.3	161.3	181.5	154.9	154.9	174.9	147.8	147.8	167.6	140.3	140.3	159.7	–	–	–
		SHC	141.1	161.3	181.5	134.9	154.9	174.9	128.1	147.8	167.6	120.9	140.3	159.7	–	–	–
	62	THC	161.7	161.7	181.1	155.0	155.0	175.0	148.0	148.0	167.7	140.4	140.4	159.8	–	–	–
		SHC	140.7	160.9	181.1	135.0	155.0	175.0	128.2	148.0	167.7	121.0	140.4	159.8	–	–	–
	67	THC	170.1	170.1	170.1	162.3	162.3	162.3	153.8	153.8	155.1	144.7	144.7	149.9	–	–	–
		SHC	119.6	139.1	158.6	116.6	136.0	155.3	113.3	132.5	151.6	109.7	128.7	147.7	–	–	–
	72	THC	182.3	182.3	182.3	174.1	174.1	174.1	165.2	165.2	165.2	155.4	155.4	155.4	–	–	–
		SHC	89.1	107.4	125.7	86.3	104.5	122.7	83.3	101.3	119.4	80.1	97.9	115.8	–	–	–
	76	THC	–	–	–	–	–	–	–	–	–	–	–	–	–	–	–
		SHC	–	–	–	–	–	–	–	–	–	–	–	–	–	–	–
6800 Cfm	58	THC	166.2	166.2	188.7	159.5	159.5	181.8	152.2	152.2	174.2	144.3	144.3	165.9	–	–	–
		SHC	143.6	166.2	188.7	137.2	159.5	181.8	130.2	152.2	174.2	122.6	144.3	165.9	–	–	–
	62	THC	166.3	166.3	188.8	159.6	159.6	181.9	152.3	152.3	174.3	144.4	144.4	166.0	–	–	–
		SHC	143.8	166.3	188.8	137.4	159.6	181.9	130.3	152.3	174.3	122.7	144.4	166.0	–	–	–
	67	THC	172.4	172.4	175.3	164.5	164.5	169.2	155.9	155.9	163.4	146.7	146.7	159.1	–	–	–
		SHC	126.9	148.8	170.7	123.8	145.5	167.3	120.3	141.9	163.4	116.3	137.6	159.1	–	–	–
	72	THC	184.4	184.4	184.4	176.1	176.1	176.1	167.0	167.0	167.0	157.1	157.1	157.1	–	–	–
		SHC	93.0	113.5	134.1	90.2	110.6	131.1	87.2	107.5	127.8	84.0	104.1	124.2	–	–	–
	76	THC	–	–	–	–	–	–	–	–	–	–	–	–	–	–	–
		SHC	–	–	–	–	–	–	–	–	–	–	–	–	–	–	–
7500 Cfm	58	THC	170.1	170.1	194.7	163.2	163.2	187.6	155.7	155.7	179.7	147.5	147.5	171.2	–	–	–
		SHC	145.4	170.1	194.7	138.8	163.2	187.6	131.6	155.7	179.7	123.8	147.5	171.2	–	–	–
	62	THC	170.2	170.2	194.8	163.3	163.3	187.7	155.8	155.8	179.8	147.6	147.6	171.3	–	–	–
		SHC	145.6	170.2	194.8	139.0	163.3	187.7	131.7	155.8	179.8	123.9	147.6	171.3	–	–	–
	67	THC	174.3	174.3	181.8	166.3	166.3	178.1	157.7	157.7	174.0	148.4	148.4	169.1	–	–	–
		SHC	133.4	157.6	181.8	130.1	154.1	178.1	126.4	150.2	174.0	122.0	145.5	169.1	–	–	–
	72	THC	186.0	186.0	186.0	177.6	177.6	177.6	168.4	168.4	168.4	158.4	158.4	158.4	–	–	–
		SHC	96.5	119.2	141.9	93.8	116.3	138.9	90.8	113.2	135.6	87.6	109.8	132.0	–	–	–
	76	THC	–	–	–	–	–	–	–	–	–	–	–	–	–	–	–
		SHC	–	–	–	–	–	–	–	–	–	–	–	–	–	–	–

– Not operational

THC – Total Cooling Capacity, Gross (1,000 Btuh)

SHC – Sensible Cooling Capacity, Gross (1,000 Btuh)

# PERFORMANCE DATA (cont.)

CAS150 – FAS150

COMBINATION RATINGS

			AMBIENT TEMPERATURE														
			85			95			105			115			125		
			EA (db)			EA (db)			EA (db)			EA (db)			EA (db)		
			75	80	85	75	80	85	75	80	85	75	80	85	75	80	85
3750 Cfm	58	THC	137.2	137.2	152.7	132.4	132.4	147.9	127.1	127.1	142.6	121.2	121.2	136.7	114.7	114.7	130.2
		SHC	121.7	137.2	152.7	117.0	132.4	147.9	111.6	127.1	142.6	105.8	121.2	136.7	99.3	114.7	130.2
	62	THC	143.2	143.2	143.2	137.3	137.3	140.1	130.6	130.6	136.8	123.3	123.3	133.1	115.5	115.5	128.8
		SHC	112.0	127.5	142.9	109.1	124.6	140.1	105.9	121.3	136.8	102.2	117.7	133.1	97.9	113.3	128.8
	67	THC	154.9	154.9	154.9	148.6	148.6	148.6	141.6	141.6	141.6	133.9	133.9	133.9	125.4	125.4	125.4
		SHC	91.1	106.5	122.0	88.4	103.9	119.4	85.5	101.0	116.5	82.3	97.8	113.3	78.9	94.3	109.8
	72	THC	166.4	166.4	166.4	160.0	160.0	160.0	152.9	152.9	152.9	144.8	144.8	144.8	135.8	135.8	135.8
		SHC	69.8	85.3	100.7	67.4	82.9	98.4	64.8	80.3	95.7	61.8	77.3	92.8	58.6	74.0	89.5
	76	THC	–	175.4	175.4	–	169.0	169.0	–	161.5	161.5	–	153.2	153.2	–	–	–
		SHC	–	67.2	82.7	–	65.5	81.0	–	63.3	78.8	–	60.7	76.2	–	–	–
4375 Cfm	58	THC	143.6	143.6	161.7	138.6	138.6	156.7	133.0	133.0	151.0	126.7	126.7	144.8	119.9	119.9	137.9
		SHC	125.6	143.6	161.7	120.6	138.6	156.7	114.9	133.0	151.0	108.7	126.7	144.8	101.8	119.9	137.9
	62	THC	147.0	147.0	155.9	140.8	140.8	152.8	134.1	134.1	149.0	127.7	127.7	141.1	120.7	120.7	134.7
		SHC	119.8	137.9	155.9	116.7	134.7	152.8	112.9	130.9	149.0	105.0	123.1	141.1	98.6	116.6	134.7
	67	THC	158.8	158.8	158.8	152.3	152.3	152.3	145.0	145.0	145.0	137.0	137.0	137.0	128.1	128.1	128.1
		SHC	96.4	114.4	132.5	93.7	111.8	129.8	90.8	108.9	126.9	87.6	105.6	123.7	84.1	102.1	120.2
	72	THC	170.6	170.6	170.6	163.9	163.9	163.9	156.3	156.3	156.3	147.8	147.8	147.8	138.6	138.6	138.6
		SHC	72.3	90.3	108.4	69.8	87.9	105.9	67.1	85.1	103.2	64.1	82.1	100.2	60.8	78.8	96.9
	76	THC	–	179.7	179.7	–	172.7	172.7	–	165.0	165.0	–	–	–	–	–	–
		SHC	–	70.7	88.7	–	68.5	86.6	–	66.1	84.1	–	–	–	–	–	–
5000 Cfm	58	THC	148.9	148.9	169.6	143.7	143.7	164.3	137.8	137.8	158.4	131.3	131.3	151.9	124.0	124.0	144.7
		SHC	128.3	148.9	169.6	123.1	143.7	164.3	117.2	137.8	158.4	110.6	131.3	151.9	103.4	124.0	144.7
	62	THC	149.9	149.9	167.0	144.2	144.2	160.8	138.6	138.6	154.4	131.8	131.8	149.5	124.0	124.0	144.7
		SHC	125.8	146.4	167.0	119.6	140.2	160.8	113.1	133.8	154.4	108.3	128.9	149.5	103.4	124.0	144.7
	67	THC	161.8	161.8	161.8	155.1	155.1	155.1	147.6	147.6	147.6	139.3	139.3	139.3	130.2	130.2	130.2
		SHC	101.4	122.0	142.6	98.7	119.3	139.9	95.7	116.3	137.0	92.4	113.0	133.7	88.8	109.5	130.1
	72	THC	173.7	173.7	173.7	166.7	166.7	166.7	158.9	158.9	158.9	150.2	150.2	150.2	140.7	140.7	140.7
		SHC	74.4	95.0	115.7	71.9	92.5	113.2	69.2	89.8	110.4	66.1	86.7	107.4	62.8	83.4	104.1
	76	THC	–	183.0	183.0	–	175.8	175.8	–	–	–	–	–	–	–	–	–
		SHC	–	73.4	94.1	–	71.2	91.8	–	–	–	–	–	–	–	–	–
5625 Cfm	58	THC	153.5	153.5	176.7	148.0	148.0	171.2	141.9	141.9	165.1	135.1	135.1	158.3	127.5	127.5	150.8
		SHC	130.2	153.5	176.7	124.8	148.0	171.2	118.7	141.9	165.1	111.9	135.1	158.3	104.3	127.5	150.8
	62	THC	153.9	153.9	171.9	148.3	148.3	168.2	141.9	141.9	165.0	135.1	135.1	158.3	127.5	127.5	150.7
		SHC	125.5	148.7	171.9	121.8	145.0	168.2	118.6	141.8	165.0	111.9	135.1	158.3	104.3	127.5	150.7
	67	THC	164.1	164.1	164.1	157.3	157.3	157.3	149.7	149.7	149.7	141.2	141.2	143.4	131.9	131.9	139.7
		SHC	106.0	129.2	152.4	103.3	126.5	149.7	100.3	123.5	146.7	97.0	120.2	143.4	93.3	116.5	139.7
	72	THC	176.2	176.2	176.2	169.0	169.0	169.0	161.0	161.0	161.0	152.1	152.1	152.1	142.4	142.4	142.4
		SHC	76.4	99.6	122.8	73.8	97.1	120.3	71.1	94.3	117.5	68.0	91.2	114.4	64.7	87.9	111.1
	76	THC	–	–	–	–	–	–	–	–	–	–	–	–	–	–	–
		SHC	–	–	–	–	–	–	–	–	–	–	–	–	–	–	–
6250 Cfm	58	THC	157.3	157.3	183.1	151.7	151.7	177.5	145.4	145.4	171.2	138.3	138.3	164.1	130.5	130.5	156.3
		SHC	131.6	157.3	183.1	125.9	151.7	177.5	119.6	145.4	171.2	112.5	138.3	164.1	104.7	130.5	156.3
	62	THC	157.3	157.3	183.1	151.7	151.7	177.5	145.4	145.4	171.1	138.3	138.3	164.1	130.5	130.5	156.3
		SHC	131.6	157.3	183.1	125.9	151.7	177.5	119.6	145.4	171.1	112.5	138.3	164.1	104.7	130.5	156.3
	67	THC	166.1	166.1	166.1	159.2	159.2	159.3	151.3	151.3	156.2	142.7	142.7	152.8	133.2	133.2	149.0
		SHC	110.5	136.3	162.0	107.8	133.5	159.3	104.7	130.5	156.2	101.3	127.0	152.8	97.4	123.2	149.0
	72	THC	178.3	178.3	178.3	170.9	170.9	170.9	162.7	162.7	162.7	153.7	153.7	153.7	143.8	143.8	143.8
		SHC	78.1	103.9	129.7	75.6	101.4	127.2	72.8	98.6	124.4	69.8	95.5	121.3	66.4	92.2	118.0
	76	THC	–	–	–	–	–	–	–	–	–	–	–	–	–	–	–
		SHC	–	–	–	–	–	–	–	–	–	–	–	–	–	–	–

– Not operational

THC – Total Cooling Capacity, Gross (1,000 Btuh)

SHC – Sensible Cooling Capacity, Gross (1,000 Btuh)

# PERFORMANCE DATA (cont.)

CAS150 – FAS180

COMBINATION RATINGS

			AMBIENT TEMPERATURE															
			85			95			105			115			125			
			EA (db)			EA (db)			EA (db)			EA (db)			EA (db)			
			75	80	85	75	80	85	75	80	85	75	80	85	75	80	85	
4500 Cfm	EA (wb)	58	THC	145.6	145.6	164.1	140.4	140.4	158.2	134.6	134.6	151.7	128.4	128.4	144.6	121.6	121.6	137.0
			SHC	127.1	145.6	164.1	122.5	140.4	158.2	117.5	134.6	151.7	112.1	128.4	144.6	106.2	121.6	137.0
		62	THC	149.1	149.1	162.7	142.7	142.7	159.2	135.8	135.8	155.2	128.8	128.8	149.6	121.7	121.7	142.3
			SHC	117.6	140.1	162.7	114.5	136.8	159.2	110.9	133.1	155.2	106.4	128.0	149.6	101.1	121.7	142.3
		67	THC	161.2	161.2	161.2	154.4	154.4	154.4	147.0	147.0	147.0	138.8	138.8	138.8	130.1	130.1	130.1
		SHC	94.6	117.4	140.3	91.8	114.6	137.5	88.8	111.6	134.5	85.6	108.4	131.2	82.1	104.9	127.7	
	72	THC	174.0	174.0	174.0	167.0	167.0	167.0	159.1	159.1	159.1	150.6	150.6	150.6	141.2	141.2	141.2	
		SHC	70.0	93.0	116.1	67.4	90.4	113.4	64.6	87.6	110.6	61.6	84.5	107.5	58.3	81.2	104.1	
		76	THC	–	184.6	184.6	–	177.3	177.3	–	169.1	169.1	–	160.1	160.1	–	150.3	150.3
			SHC	–	72.9	96.6	–	70.5	94.0	–	67.7	91.2	–	64.8	88.2	–	61.6	85.0
5300 Cfm	EA (wb)	58	THC	152.7	152.7	172.0	147.0	147.0	165.7	140.9	140.9	158.8	134.3	134.3	151.3	127.0	127.0	143.1
			SHC	133.2	152.7	172.0	128.4	147.0	165.7	123.1	140.9	158.8	117.3	134.3	151.3	110.8	127.0	143.1
		62	THC	153.6	153.6	176.8	147.4	147.4	171.5	141.0	141.0	165.0	134.4	134.4	157.2	127.1	127.1	148.6
			SHC	126.2	151.5	176.8	122.0	146.8	171.5	117.2	141.0	165.0	111.6	134.4	157.2	105.6	127.1	148.6
		67	THC	164.9	164.9	164.9	157.8	157.8	157.9	150.2	150.2	150.6	141.7	141.7	144.5	132.6	132.6	140.7
		SHC	100.8	127.3	153.7	98.0	124.5	150.9	95.0	121.4	147.8	91.7	118.1	144.5	88.1	114.4	140.7	
	72	THC	177.6	177.6	177.6	170.3	170.3	170.3	162.2	162.2	162.2	153.3	153.3	153.3	143.7	143.7	143.7	
		SHC	72.4	99.1	125.7	69.9	96.5	123.1	67.0	93.7	120.2	64.0	90.6	117.1	60.6	87.2	113.7	
		76	THC	–	188.2	188.2	–	180.6	180.6	–	172.1	172.1	–	162.9	162.9	–	152.8	152.8
			SHC	–	76.0	103.2	–	73.5	100.6	–	70.8	97.9	–	67.9	94.9	–	64.7	91.6
6000 Cfm	EA (wb)	58	THC	157.7	157.7	177.7	151.8	151.8	171.1	145.5	145.5	163.9	138.5	138.5	156.1	130.9	130.9	147.5
			SHC	137.6	157.7	177.7	132.6	151.8	171.1	127.0	145.5	163.9	120.9	138.5	156.1	114.3	130.9	147.5
		62	THC	157.8	157.8	184.5	152.0	152.0	177.7	145.6	145.6	170.2	138.6	138.6	162.1	131.0	131.0	153.2
			SHC	131.1	157.8	184.5	126.2	152.0	177.7	120.9	145.6	170.2	115.1	138.6	162.1	108.8	131.0	153.2
		67	THC	167.2	167.2	167.2	160.1	160.1	162.1	152.3	152.3	158.9	143.7	143.7	155.3	134.6	134.6	151.3
		SHC	105.9	135.5	165.0	103.1	132.6	162.1	100.0	129.5	158.9	96.7	126.0	155.3	93.0	122.1	151.3	
	72	THC	180.0	180.0	180.0	172.6	172.6	172.6	164.3	164.3	164.3	155.3	155.3	155.3	145.4	145.4	145.4	
		SHC	74.5	104.3	134.0	72.0	101.6	131.3	69.1	98.8	128.4	66.1	95.7	125.3	62.7	92.3	121.9	
		76	THC	–	190.6	190.6	–	182.8	182.8	–	174.2	174.2	–	164.8	164.8	–	154.6	154.6
			SHC	–	78.6	108.9	–	76.1	106.3	–	73.4	103.5	–	70.5	100.5	–	67.3	97.3
6800 Cfm	EA (wb)	58	THC	162.2	162.2	182.9	156.2	156.2	176.1	149.6	149.6	168.6	142.4	142.4	160.4	134.5	134.5	151.5
			SHC	141.7	162.2	182.9	136.4	156.2	176.1	130.7	149.6	168.6	124.3	142.4	160.4	117.4	134.5	151.5
		62	THC	162.4	162.4	190.0	156.3	156.3	182.9	149.7	149.7	175.1	142.5	142.5	166.6	134.6	134.6	157.3
			SHC	134.9	162.4	190.0	129.9	156.3	182.9	124.4	149.7	175.1	118.4	142.5	166.6	111.8	134.6	157.3
		67	THC	169.5	169.5	177.2	162.2	162.2	174.2	154.3	154.3	170.7	145.7	145.7	166.7	136.4	136.4	162.1
		SHC	111.5	144.4	177.2	108.6	141.4	174.2	105.5	138.1	170.7	101.9	134.4	166.7	98.1	130.0	162.1	
	72	THC	182.2	182.2	182.2	174.6	174.6	174.6	166.2	166.2	166.2	157.0	157.0	157.0	146.9	146.9	146.9	
		SHC	76.8	109.9	143.1	74.2	107.3	140.5	71.4	104.4	137.6	68.3	101.3	134.5	65.0	97.9	131.0	
		76	THC	–	–	–	–	–	–	–	–	–	–	–	–	–	–	–
			SHC	–	–	–	–	–	–	–	–	–	–	–	–	–	–	–
7500 Cfm	EA (wb)	58	THC	165.7	165.7	186.8	159.6	159.6	179.8	152.7	152.7	172.1	145.2	145.2	163.7	137.1	137.1	154.5
			SHC	144.7	165.7	186.8	139.3	159.6	179.8	133.4	152.7	172.1	126.8	145.2	163.7	119.7	137.1	154.5
		62	THC	165.9	165.9	193.9	159.6	159.6	186.7	152.8	152.8	178.7	145.3	145.3	169.9	137.2	137.2	160.4
			SHC	137.8	165.9	193.9	132.6	159.6	186.7	126.9	152.8	178.7	120.7	145.3	169.9	113.9	137.2	160.4
		67	THC	171.2	171.2	187.4	163.9	163.9	184.1	155.9	155.9	180.3	147.2	147.2	175.8	137.9	137.9	170.1
		SHC	116.2	151.8	187.4	113.2	148.7	184.1	109.9	145.1	180.3	106.2	141.0	175.8	101.8	135.9	170.1	
	72	THC	183.8	183.8	183.8	176.0	176.0	176.0	167.5	167.5	167.5	158.2	158.2	158.2	148.0	148.0	148.0	
		SHC	78.7	114.8	150.9	76.1	112.2	148.3	73.3	109.3	145.4	70.2	106.2	142.2	66.9	102.8	138.7	
		76	THC	–	–	–	–	–	–	–	–	–	–	–	–	–	–	–
			SHC	–	–	–	–	–	–	–	–	–	–	–	–	–	–	–

– Not operational

THC – Total Cooling Capacity, Gross (1,000 Btuh)

SHC – Sensible Cooling Capacity, Gross (1,000 Btuh)



# PERFORMANCE DATA (cont.)

CAS181 – FAS180

COMBINATION RATINGS

			AMBIENT TEMPERATURE														
			85			95			105			115			125		
			EA (db)			EA (db)			EA (db)			EA (db)			EA (db)		
			75	80	85	75	80	85	75	80	85	75	80	85	75	80	85
4500 Cfm	58	THC	169.9	169.9	190.5	164.1	164.1	184.2	157.5	157.5	176.8	151.4	151.4	170.0	–	–	–
		SHC	148.9	169.7	190.5	143.9	164.1	184.2	138.1	157.5	176.8	132.7	151.4	170.0	–	–	–
	62	THC	178.8	178.8	178.8	171.5	171.5	174.3	163.3	163.3	170.5	155.3	155.3	166.3	146.7	146.7	161.9
		SHC	133.1	155.4	177.8	129.5	151.9	174.3	125.7	148.1	170.5	121.7	144.0	166.3	117.4	139.7	161.9
	67	THC	193.8	193.8	193.8	186.0	186.0	186.0	177.5	177.5	177.5	168.6	168.6	168.6	–	–	–
		SHC	108.6	130.7	152.8	105.2	127.4	149.5	101.6	123.8	146.0	97.8	120.1	142.4	–	–	–
	72	THC	210.1	210.1	210.1	201.7	201.7	201.7	192.6	192.6	192.6	182.7	182.7	182.7	–	–	–
		SHC	85.0	106.1	127.1	81.6	103.0	124.3	77.9	99.5	121.1	74.0	95.9	117.7	–	–	–
	76	THC	–	223.4	223.4	–	215.0	215.0	–	205.5	205.5	–	194.8	194.8	–	–	–
		SHC	–	86.6	111.3	–	82.8	107.5	–	79.6	104.3	–	76.5	101.3	–	–	–
5250 Cfm	58	THC	178.2	178.2	200.2	172.0	172.0	193.3	164.8	164.8	185.2	158.4	158.4	178.0	150.6	150.6	169.3
		SHC	156.3	178.2	200.2	150.8	172.0	193.3	144.4	164.8	185.2	138.7	158.4	178.0	131.9	150.6	169.3
	62	THC	184.0	184.0	193.8	176.0	176.0	189.8	167.6	167.6	185.5	159.7	159.7	180.7	151.0	151.0	174.3
		SHC	142.4	168.1	193.8	138.5	164.1	189.8	134.4	160.0	185.5	130.1	155.4	180.7	124.8	149.6	174.3
	67	THC	199.0	199.0	199.0	190.8	190.8	190.8	181.6	181.6	181.6	172.6	172.6	172.6	–	–	–
		SHC	114.5	140.0	165.6	111.0	136.6	162.2	107.2	132.9	158.6	103.5	129.2	154.9	–	–	–
	72	THC	215.3	215.3	215.3	206.5	206.5	206.5	196.9	196.9	196.9	186.7	186.7	186.7	–	–	–
		SHC	87.1	111.9	136.7	83.7	108.7	133.7	80.0	105.2	130.3	76.2	101.4	126.7	–	–	–
	76	THC	–	229.0	229.0	–	219.8	219.8	–	209.6	209.6	–	198.7	198.7	–	–	–
		SHC	–	89.0	117.8	–	86.3	115.2	–	83.2	105.2	–	79.7	103.1	–	–	–
6000 Cfm	58	THC	185.2	185.2	208.1	178.7	178.7	200.8	170.9	170.9	192.2	164.2	164.2	184.6	156.1	156.1	175.6
		SHC	162.2	185.2	208.1	156.5	178.7	200.8	149.6	170.9	192.2	143.7	164.2	184.6	136.6	156.1	175.6
	62	THC	188.1	188.1	208.1	180.3	180.3	203.5	–	–	–	164.5	164.5	189.5	156.3	156.3	181.6
		SHC	150.7	179.4	208.1	146.6	175.1	203.5	–	–	–	135.6	162.5	189.5	129.7	155.6	181.6
	67	THC	203.1	203.1	203.1	194.6	194.6	194.6	185.6	185.6	185.6	175.8	175.8	175.8	–	–	–
		SHC	120.0	148.9	177.8	116.6	145.5	174.4	112.8	141.8	170.8	108.9	137.9	166.9	–	–	–
	72	THC	219.3	219.3	219.3	210.2	210.2	210.2	200.2	200.2	200.2	189.8	189.8	189.8	–	–	–
		SHC	89.2	117.4	145.7	85.8	114.2	142.6	82.0	110.6	139.1	78.2	106.8	135.5	–	–	–
	76	THC	–	232.9	232.9	–	223.4	223.4	–	213.1	213.1	–	201.9	201.9	–	–	–
		SHC	–	92.4	116.9	–	89.4	115.2	–	86.2	112.9	–	82.6	110.0	–	–	–
6750 Cfm	58	THC	191.0	191.0	214.8	184.2	184.2	207.2	176.6	176.6	198.6	169.0	169.0	190.1	160.6	160.6	180.7
		SHC	167.3	191.0	214.8	161.2	184.2	207.2	154.5	176.6	198.6	147.8	169.0	190.1	140.5	160.6	180.7
	62	THC	192.1	192.1	219.7	184.5	184.5	212.5	177.8	177.8	202.9	168.9	168.9	197.3	160.6	160.6	187.6
		SHC	157.7	188.7	219.7	152.1	182.3	212.5	145.5	174.2	202.9	140.6	168.9	197.3	133.6	160.6	187.6
	67	THC	206.4	206.4	206.4	197.7	197.7	197.7	188.2	188.2	188.2	178.4	178.4	178.5	–	–	–
		SHC	125.4	157.5	189.7	121.8	154.0	186.2	118.0	150.2	182.5	114.1	146.3	178.5	–	–	–
	72	THC	222.5	222.5	222.5	213.1	213.1	213.1	203.1	203.1	203.1	192.4	192.4	192.4	–	–	–
		SHC	91.1	122.7	154.3	87.7	119.4	151.1	84.0	115.8	147.5	80.2	112.1	144.0	–	–	–
	76	THC	–	236.1	236.1	–	226.5	226.5	–	215.9	215.9	–	204.4	204.4	–	–	–
		SHC	–	95.3	124.6	–	92.3	122.2	–	89.0	119.5	–	85.4	116.3	–	–	–
7500 Cfm	58	THC	196.0	196.0	220.5	189.0	189.0	212.6	181.2	181.2	204.0	173.1	173.1	194.8	–	–	–
		SHC	171.5	196.0	220.5	165.3	189.0	212.6	158.5	181.2	204.0	151.4	173.1	194.8	–	–	–
	62	THC	196.1	196.1	228.2	189.0	189.0	220.6	182.3	182.3	207.2	173.1	173.1	202.2	–	–	–
		SHC	162.9	195.5	228.2	157.3	189.0	220.6	148.6	177.9	207.2	144.0	173.1	202.2	–	–	–
	67	THC	209.1	209.1	209.1	200.2	200.2	200.2	190.5	190.5	193.8	180.5	180.5	189.7	–	–	–
		SHC	130.5	165.8	201.1	126.9	162.2	197.6	123.1	158.4	193.8	119.1	154.4	189.7	–	–	–
	72	THC	225.2	225.2	225.2	215.6	215.6	215.6	205.4	205.4	205.4	194.4	194.4	194.4	–	–	–
		SHC	93.0	127.9	162.7	89.6	124.5	159.4	85.9	120.9	155.9	82.0	117.1	152.2	–	–	–
	76	THC	–	238.9	238.9	–	229.0	229.0	–	218.1	218.1	–	206.4	206.4	–	–	–
		SHC	–	98.1	131.2	–	95.0	128.6	–	91.6	125.6	–	88.0	122.3	–	–	–

– Not operational

THC – Total Cooling Capacity, Gross (1,000 Btuh)

SHC – Sensible Cooling Capacity, Gross (1,000 Btuh)

# PERFORMANCE DATA (cont.)

CAS181 – FAS240

COMBINATION RATINGS

			AMBIENT TEMPERATURE															
			85			95			105			115			125			
			EA (db)			EA (db)			EA (db)			EA (db)			EA (db)			
			75	80	85	75	80	85	75	80	85	75	80	85	75	80	85	
6000 Cfm	EA (wb)	58	THC	188.1	188.1	211.9	181.9	181.9	205.0	175.2	175.2	197.4	167.8	167.8	189.1	159.7	159.7	180.0
			SHC	164.2	188.1	211.9	158.8	181.9	205.0	153.0	175.2	197.4	146.5	167.8	189.1	139.4	159.7	180.0
		62	THC	189.5	189.5	216.5	182.5	182.5	212.0	175.4	175.4	205.1	168.0	168.0	196.4	159.8	159.8	186.9
			SHC	154.7	185.6	216.5	150.8	181.4	212.0	145.7	175.4	205.1	139.5	168.0	196.4	132.7	159.8	186.9
		67	THC	203.3	203.3	203.3	195.6	195.6	195.6	187.2	187.2	187.2	177.9	177.9	177.9	167.8	167.8	172.0
		SHC	123.2	154.9	186.5	120.1	151.7	183.3	116.7	148.3	179.9	113.0	144.6	176.1	109.0	140.5	172.0	
	72	THC	218.9	218.9	218.9	210.9	210.9	210.9	202.0	202.0	202.0	192.1	192.1	192.1	181.3	181.3	181.3	
		SHC	90.2	122.0	153.8	87.2	119.0	150.8	84.0	115.8	147.5	80.5	112.2	143.9	76.7	108.3	140.0	
		76	THC	–	232.4	232.4	–	224.0	224.0	–	214.7	214.7	–	–	–	–	–	–
			SHC	–	95.8	128.2	–	92.9	125.2	–	89.8	122.0	–	–	–	–	–	–
7000 Cfm	EA (wb)	58	THC	195.8	195.8	220.6	189.4	189.4	213.4	182.3	182.3	205.4	174.5	174.5	196.6	165.8	165.8	186.9
			SHC	171.0	195.8	220.6	165.3	189.4	213.4	159.1	182.3	205.4	152.4	174.5	196.6	144.8	165.8	186.9
		62	THC	196.0	196.0	229.2	189.5	189.5	221.6	182.4	182.4	213.3	174.6	174.6	204.2	166.0	166.0	194.1
			SHC	162.8	196.0	229.2	157.4	189.5	221.6	151.5	182.4	213.3	145.1	174.6	204.2	137.9	166.0	194.1
		67	THC	207.2	207.2	207.2	199.2	199.2	201.0	190.5	190.5	197.4	181.1	181.1	193.5	170.7	170.7	189.2
		SHC	131.3	167.8	204.3	128.1	164.6	201.0	124.6	161.0	197.4	120.9	157.2	193.5	116.8	153.0	189.2	
	72	THC	222.7	222.7	222.7	214.4	214.4	214.4	205.4	205.4	205.4	195.2	195.2	195.2	184.1	184.1	184.1	
		SHC	93.3	130.0	166.6	90.3	127.0	163.6	87.1	123.7	160.3	83.6	120.1	156.7	79.7	116.2	152.7	
		76	THC	–	236.5	236.5	–	–	–	–	–	–	–	–	–	–	–	–
			SHC	–	100.0	137.1	–	–	–	–	–	–	–	–	–	–	–	–
8000 Cfm	EA (wb)	58	THC	202.0	202.0	227.6	195.3	195.3	220.1	187.9	187.9	211.8	179.8	179.8	202.6	170.7	170.7	192.4
			SHC	176.4	202.0	227.6	170.5	195.3	220.1	164.1	187.9	211.8	157.0	179.8	202.6	149.1	170.7	192.4
		62	THC	202.1	202.1	236.4	195.4	195.4	228.5	188.0	188.0	219.9	179.9	179.9	210.4	170.8	170.8	199.8
			SHC	167.9	202.1	236.4	162.3	195.4	228.5	156.2	188.0	219.9	149.4	179.9	210.4	141.9	170.8	199.8
		67	THC	210.1	210.1	221.2	202.1	202.1	217.8	193.3	193.3	214.0	183.7	183.7	209.7	173.2	173.2	204.8
		SHC	138.9	180.0	221.2	135.7	176.7	217.8	132.2	173.1	214.0	128.3	169.0	209.7	124.0	164.4	204.8	
	72	THC	225.7	225.7	225.7	217.3	217.3	217.3	207.9	207.9	207.9	197.6	197.6	197.6	186.2	186.2	186.2	
		SHC	96.3	137.7	179.1	93.4	134.7	176.1	90.1	131.4	172.8	86.6	127.8	169.1	82.7	123.9	165.1	
		76	THC	–	–	–	–	–	–	–	–	–	–	–	–	–	–	–
			SHC	–	–	–	–	–	–	–	–	–	–	–	–	–	–	–
9000 Cfm	EA (wb)	58	THC	207.1	207.1	233.4	200.2	200.2	225.6	192.6	192.6	217.0	184.1	184.1	207.4	174.8	174.8	196.9
			SHC	180.8	207.1	233.4	174.8	200.2	225.6	168.2	192.6	217.0	160.7	184.1	207.4	152.6	174.8	196.9
		62	THC	207.2	207.2	242.3	200.3	200.3	234.2	192.7	192.7	225.3	184.2	184.2	215.4	174.9	174.9	204.5
			SHC	172.1	207.2	242.3	166.4	200.3	234.2	160.1	192.7	225.3	153.0	184.2	215.4	145.3	174.9	204.5
		67	THC	212.6	212.6	237.2	204.5	204.5	233.5	195.6	195.6	229.3	186.0	186.0	224.4	175.5	175.5	217.9
		SHC	146.2	191.7	237.2	142.9	188.2	233.5	139.2	184.3	229.3	135.1	179.7	224.4	130.1	174.0	217.9	
	72	THC	228.0	228.0	228.0	219.4	219.4	219.4	209.9	209.9	209.9	199.5	199.5	199.5	187.9	187.9	187.9	
		SHC	99.2	145.3	191.4	96.3	142.3	188.3	93.0	139.0	184.9	89.5	135.4	181.2	85.6	131.4	177.2	
		76	THC	–	–	–	–	–	–	–	–	–	–	–	–	–	–	–
			SHC	–	–	–	–	–	–	–	–	–	–	–	–	–	–	–
10,000 Cfm	EA (wb)	58	THC	211.4	211.4	238.2	204.3	204.3	230.2	196.4	196.4	221.4	187.8	187.8	211.6	178.1	178.1	200.7
			SHC	184.6	211.4	238.2	178.4	204.3	230.2	171.5	196.4	221.4	164.0	187.8	211.6	155.5	178.1	200.7
		62	THC	211.5	211.5	247.3	204.4	204.4	239.0	196.6	196.6	229.8	187.9	187.9	219.7	178.2	178.2	208.3
			SHC	175.7	211.5	247.3	169.8	204.4	239.0	163.3	196.6	229.8	156.1	187.9	219.7	148.0	178.2	208.3
		67	THC	214.6	214.6	251.9	206.6	206.6	247.8	197.8	197.8	242.7	188.2	188.2	235.9	178.3	178.3	223.5
		SHC	152.9	202.4	251.9	149.4	198.6	247.8	145.4	194.0	242.7	140.5	188.2	235.9	133.1	178.3	223.5	
	72	THC	229.9	229.9	229.9	221.2	221.2	221.2	211.6	211.6	211.6	201.0	201.0	201.0	–	–	–	
		SHC	102.1	152.7	203.3	99.1	149.7	200.2	95.9	146.4	196.9	92.3	142.7	193.1	–	–	–	
		76	THC	–	–	–	–	–	–	–	–	–	–	–	–	–	–	–
			SHC	–	–	–	–	–	–	–	–	–	–	–	–	–	–	–

– Not operational

THC – Total Cooling Capacity, Gross (1,000 Btuh)

SHC – Sensible Cooling Capacity, Gross (1,000 Btuh)

# PERFORMANCE DATA (cont.)

CAS180 – FAS180

COMBINATION RATINGS

			AMBIENT TEMPERATURE														
			85			95			105			115			125		
			EA (db)			EA (db)			EA (db)			EA (db)			EA (db)		
			75	80	85	75	80	85	75	80	85	75	80	85	75	80	85
4500 Cfm	58	THC	168.2	168.2	185.7	161.9	161.9	181.8	156.0	156.0	175.2	149.4	149.4	167.8	143.0	143.0	160.7
		SHC	145.7	165.7	185.7	142.0	161.9	181.8	136.7	156.0	175.2	130.9	149.4	167.8	125.3	143.0	160.7
	62	THC	176.6	176.6	176.6	169.7	169.7	172.9	162.2	162.2	169.3	153.7	153.7	165.1	145.0	145.0	160.6
		SHC	131.8	154.0	176.2	128.4	150.7	172.9	124.8	147.0	169.3	120.7	142.9	165.1	116.4	138.5	160.6
	67	THC	192.7	192.7	192.7	185.3	185.3	185.3	177.2	177.2	177.2	168.0	168.0	168.0	158.8	158.8	158.8
		SHC	108.2	130.1	151.9	104.9	126.9	148.9	101.5	123.5	145.5	97.6	119.7	141.8	93.7	115.9	138.1
	72	THC	210.4	210.4	210.4	202.4	202.4	202.4	193.7	193.7	193.7	184.1	184.1	184.1	173.7	173.7	173.7
		SHC	85.4	106.0	126.6	82.1	103.1	124.0	78.6	99.8	121.1	74.9	96.3	117.8	70.9	92.5	114.2
	76	THC	–	224.8	224.8	–	216.8	216.8	–	207.7	207.7	–	197.7	197.7	–	186.5	186.5
		SHC	–	86.9	111.7	–	83.2	107.9	–	80.0	104.8	–	77.2	102.0	–	73.8	96.1
5250 Cfm	58	THC	175.7	175.7	197.4	169.9	169.9	190.9	163.6	163.6	183.9	157.0	157.0	176.5	148.9	148.9	167.4
		SHC	154.0	175.7	197.4	148.9	169.9	190.9	143.3	163.6	183.9	137.5	157.0	176.5	130.3	148.9	167.4
	62	THC	181.7	181.7	192.0	174.2	174.2	188.1	166.6	166.6	184.0	157.8	157.8	179.0	149.9	149.9	172.2
		SHC	141.0	166.5	192.0	137.2	162.7	188.1	133.4	158.7	184.0	128.8	153.9	179.0	123.4	147.8	172.2
	67	THC	198.0	198.0	198.0	190.1	190.1	190.1	181.6	181.6	181.6	172.0	172.0	172.0	162.6	162.6	162.6
		SHC	114.1	139.4	164.7	110.7	136.1	161.5	107.2	132.6	158.1	103.3	128.8	154.3	99.4	124.9	150.4
	72	THC	215.8	215.8	215.8	207.4	207.4	207.4	198.2	198.2	198.2	188.3	188.3	188.3	177.5	177.5	177.5
		SHC	87.6	112.0	136.4	84.4	108.9	133.5	80.8	105.6	130.4	77.1	102.0	127.0	73.1	98.2	123.3
	76	THC	–	230.9	230.9	–	222.1	222.1	–	212.5	212.5	–	202.0	202.0	–	190.4	190.4
		SHC	–	89.4	118.3	–	86.8	115.7	–	83.9	109.4	–	80.7	103.0	–	77.0	100.5
6000 Cfm	58	THC	182.7	182.7	205.3	176.5	176.5	198.5	169.9	169.9	191.0	162.2	162.2	182.4	154.7	154.7	174.0
		SHC	160.0	182.7	205.3	154.6	176.5	198.5	148.7	169.9	191.0	142.0	162.2	182.4	135.3	154.7	174.0
	62	THC	185.8	185.8	205.9	178.6	178.6	200.2	170.8	170.8	195.6	163.3	163.3	186.9	155.9	155.9	177.2
		SHC	149.1	177.5	205.9	144.4	172.3	200.2	140.3	167.9	195.6	134.0	160.5	186.9	127.2	152.2	177.2
	67	THC	202.0	202.0	202.0	193.9	193.9	193.9	185.0	185.0	185.0	175.4	175.4	175.4	165.2	165.2	165.2
		SHC	119.6	148.2	176.9	116.3	144.9	173.6	112.6	141.3	170.1	108.7	137.5	166.3	104.6	133.4	162.2
	72	THC	219.9	219.9	219.9	211.2	211.2	211.2	201.7	201.7	201.7	191.8	191.8	191.8	180.4	180.4	180.4
		SHC	89.8	117.6	145.4	86.5	114.5	142.5	82.9	111.1	139.2	79.2	107.3	135.4	75.1	103.6	132.0
	76	THC	–	235.1	235.1	–	226.2	226.2	–	216.2	216.2	–	205.2	205.2	–	193.3	193.3
		SHC	–	92.9	121.7	–	90.2	114.7	–	87.1	112.8	–	83.7	110.2	–	79.9	107.2
6750 Cfm	58	THC	188.5	188.5	212.0	182.1	182.1	204.8	175.1	175.1	197.0	167.0	167.0	187.9	159.2	159.2	179.2
		SHC	165.0	188.5	212.0	159.4	182.1	204.8	153.2	175.1	197.0	146.1	167.0	187.9	139.2	159.2	179.2
	62	THC	189.7	189.7	216.7	183.3	183.3	208.6	176.4	176.4	200.6	168.7	168.7	191.6	159.2	159.2	185.9
		SHC	155.5	186.1	216.7	149.8	179.2	208.6	144.0	172.3	200.6	137.5	164.6	191.6	132.4	159.2	185.9
	67	THC	205.3	205.3	205.3	196.8	196.8	196.8	187.8	187.8	187.8	178.1	178.1	178.1	167.5	167.5	173.4
		SHC	124.9	156.7	188.6	121.5	153.3	185.2	117.8	149.7	181.6	113.9	145.7	177.6	109.6	141.5	173.4
	72	THC	223.3	223.3	223.3	214.3	214.3	214.3	204.6	204.6	204.6	194.2	194.2	194.2	182.6	182.6	182.6
		SHC	91.8	122.9	154.0	88.5	119.7	151.0	84.9	116.3	147.7	81.2	112.7	144.2	77.1	108.7	140.3
	76	THC	–	238.8	238.8	–	229.4	229.4	–	219.1	219.1	–	207.9	207.9	–	195.4	195.4
		SHC	–	96.1	124.2	–	93.2	122.1	–	90.0	119.6	–	86.5	116.7	–	82.6	113.3
7500 Cfm	58	THC	193.5	193.5	217.7	186.9	186.9	210.2	179.6	179.6	202.1	171.5	171.5	193.1	163.1	163.1	183.6
		SHC	169.3	193.5	217.7	163.5	186.9	210.2	157.1	179.6	202.1	150.0	171.5	193.1	142.6	163.1	183.6
	62	THC	194.9	194.9	221.2	188.2	188.2	213.2	180.1	180.1	207.5	171.5	171.5	200.4	163.1	163.1	190.6
		SHC	158.8	190.0	221.2	153.1	183.2	213.2	148.3	177.9	207.5	142.6	171.5	200.4	135.6	163.1	190.6
	67	THC	207.9	207.9	207.9	199.3	199.3	199.3	190.0	190.0	192.6	180.1	180.1	188.7	169.2	169.2	184.2
		SHC	129.9	164.9	199.8	126.4	161.4	196.4	122.7	157.7	192.6	118.7	153.7	188.7	114.4	149.3	184.2
	72	THC	226.0	226.0	226.0	216.9	216.9	216.9	207.0	207.0	207.0	196.3	196.3	196.3	184.4	184.4	184.4
		SHC	93.7	128.1	162.4	90.4	124.9	159.3	86.9	121.5	156.0	83.1	117.7	152.4	78.9	113.6	148.4
	76	THC	–	241.7	241.7	–	232.1	232.1	–	221.6	221.6	–	210.1	210.1	–	197.2	197.2
		SHC	–	98.9	131.0	–	96.0	128.6	–	92.7	125.9	–	89.2	122.7	–	85.2	119.2

– Not operational

THC – Total Cooling Capacity, Gross (1,000 Btuh)

SHC – Sensible Cooling Capacity, Gross (1,000 Btuh)

# PERFORMANCE DATA (cont.)

CAS180 – FAS240

COMBINATION RATINGS

			AMBIENT TEMPERATURE														
			85			95			105			115			125		
			EA (db)			EA (db)			EA (db)			EA (db)			EA (db)		
			75	80	85	75	80	85	75	80	85	75	80	85	75	80	85
6000 Cfm	58	THC	189.5	189.5	213.0	182.9	182.9	205.6	175.8	175.8	197.7	168.1	168.1	189.0	159.8	159.8	179.8
		SHC	166.0	189.5	213.0	160.2	182.9	205.6	154.0	175.8	197.7	147.1	168.1	189.0	139.9	159.8	179.8
	62	THC	191.7	191.7	215.9	184.0	184.0	211.1	176.3	176.3	203.9	168.3	168.3	196.3	159.8	159.8	186.5
		SHC	155.8	185.8	215.9	151.6	181.3	211.1	146.0	174.9	203.9	140.1	168.2	196.3	133.1	159.8	186.5
	67	THC	207.6	207.6	207.6	199.1	199.1	199.1	189.8	189.8	189.8	180.1	180.1	180.1	169.2	169.2	170.3
		SHC	124.8	155.7	186.5	121.3	152.1	182.9	117.4	148.2	179.0	113.5	144.3	175.1	108.9	139.6	170.3
	72	THC	225.6	225.6	225.6	216.6	216.6	216.6	206.8	206.8	206.8	196.1	196.1	196.1	184.7	184.7	184.7
		SHC	92.7	123.8	154.8	89.3	120.4	151.4	85.7	116.7	147.7	81.8	112.7	143.7	77.6	108.5	139.5
	76	THC	–	240.7	240.7	–	231.2	231.2	–	220.8	220.8	–	209.6	209.6	–	–	–
		SHC	–	98.4	130.4	–	95.2	127.1	–	91.6	123.4	–	87.8	119.4	–	–	–
7000 Cfm	58	THC	197.6	197.6	222.2	190.6	190.6	214.3	183.0	183.0	205.9	174.8	174.8	196.7	165.9	165.9	186.6
		SHC	173.0	197.6	222.2	166.8	190.6	214.3	160.1	183.0	205.9	152.9	174.8	196.7	145.2	165.9	186.6
	62	THC	197.6	197.6	230.6	190.6	190.6	222.5	183.0	183.0	213.6	174.8	174.8	204.1	165.8	165.8	193.7
		SHC	164.6	197.6	230.6	158.8	190.6	222.5	152.3	183.0	213.6	145.5	174.8	204.1	138.0	165.8	193.7
	67	THC	211.7	211.7	211.7	202.9	202.9	202.9	193.4	193.4	195.5	183.1	183.1	191.2	172.1	172.1	186.3
		SHC	132.4	167.8	203.3	128.7	164.1	199.6	124.8	160.2	195.5	120.6	155.9	191.2	116.0	151.2	186.3
	72	THC	229.8	229.8	229.8	220.5	220.5	220.5	210.3	210.3	210.3	199.3	199.3	199.3	187.6	187.6	187.6
		SHC	95.6	131.3	167.0	92.2	127.9	163.6	88.5	124.2	159.8	84.6	120.1	155.7	80.4	115.8	151.3
	76	THC	–	245.1	245.1	–	235.3	235.3	–	224.5	224.5	–	–	–	–	–	–
		SHC	–	102.4	138.9	–	99.1	135.5	–	95.5	131.8	–	–	–	–	–	–
8000 Cfm	58	THC	204.0	204.0	229.5	196.7	196.7	221.4	188.8	188.8	212.5	180.1	180.1	202.8	170.9	170.9	192.3
		SHC	178.5	204.0	229.5	172.1	196.7	221.4	165.1	188.8	212.5	157.5	180.1	202.8	149.4	170.9	192.3
	62	THC	204.0	204.0	238.2	196.6	196.6	229.7	188.7	188.7	220.5	180.2	180.2	210.5	170.8	170.8	199.6
		SHC	169.8	204.0	238.2	163.6	196.6	229.7	157.0	188.7	220.5	149.8	180.2	210.5	142.0	170.8	199.6
	67	THC	214.7	214.7	219.1	205.8	205.8	215.2	196.1	196.1	211.0	185.7	185.7	206.3	174.5	174.5	201.0
		SHC	139.4	179.2	219.1	135.7	175.5	215.2	131.7	171.3	211.0	127.3	166.8	206.3	122.6	161.8	201.0
	72	THC	232.9	232.9	232.9	223.4	223.4	223.4	213.0	213.0	213.0	201.7	201.7	201.7	189.2	189.2	189.2
		SHC	98.4	138.6	178.8	94.9	135.1	175.3	91.2	131.3	171.4	87.2	127.2	167.3	82.8	122.8	162.7
	76	THC	–	248.6	248.6	–	–	–	–	–	–	–	–	–	–	–	–
		SHC	–	106.2	147.2	–	–	–	–	–	–	–	–	–	–	–	–
9000 Cfm	58	THC	209.3	209.3	235.6	201.8	201.8	227.2	193.6	193.6	217.9	184.6	184.6	207.9	174.9	174.9	197.0
		SHC	183.0	209.3	235.6	176.5	201.8	227.2	169.2	193.6	217.9	161.3	184.6	207.9	152.8	174.9	197.0
	62	THC	209.3	209.3	244.5	201.7	201.7	235.7	193.5	193.5	226.2	184.6	184.6	215.8	174.9	174.9	204.5
		SHC	174.1	209.3	244.5	167.8	201.7	235.7	160.9	193.5	226.2	153.4	184.6	215.8	145.3	174.9	204.5
	67	THC	217.2	217.2	234.0	208.2	208.2	230.1	198.2	198.2	225.4	187.7	187.7	220.1	176.6	176.6	213.6
		SHC	145.9	190.0	234.0	142.2	186.1	230.1	138.0	181.7	225.4	133.4	176.7	220.1	128.2	170.9	213.6
	72	THC	235.4	235.4	235.4	225.7	225.7	225.7	215.1	215.1	215.1	203.7	203.7	203.7	191.4	191.4	191.4
		SHC	100.9	145.5	190.0	97.5	142.0	186.5	93.7	138.1	182.6	89.7	134.0	178.3	85.4	129.6	173.7
	76	THC	–	–	–	–	–	–	–	–	–	–	–	–	–	–	–
		SHC	–	–	–	–	–	–	–	–	–	–	–	–	–	–	–
10,000 Cfm	58	THC	213.8	213.8	240.8	206.1	206.1	232.1	197.6	197.6	222.6	188.3	188.3	212.1	178.4	178.4	201.0
		SHC	186.9	213.8	240.8	180.1	206.1	232.1	172.7	197.6	222.6	164.5	188.3	212.1	155.8	178.4	201.0
	62	THC	213.8	213.8	249.9	206.0	206.0	240.8	197.6	197.6	231.0	188.3	188.3	220.3	178.3	178.3	208.6
		SHC	177.8	213.8	249.9	171.2	206.0	240.8	164.1	197.6	231.0	156.4	188.3	220.3	148.0	178.3	208.6
	67	THC	219.3	219.3	248.2	210.1	210.1	243.6	200.2	200.2	238.3	189.7	189.7	232.2	178.9	178.9	222.0
		SHC	152.2	200.2	248.2	148.2	195.9	243.6	143.7	191.0	238.3	138.8	185.5	232.2	132.0	177.0	222.0
	72	THC	237.4	237.4	237.4	227.6	227.6	227.6	216.8	216.8	216.8	205.2	205.2	205.2	192.7	192.7	192.7
		SHC	103.4	152.2	201.1	99.9	148.7	197.5	96.1	144.8	193.5	92.1	140.7	189.2	87.7	136.1	184.5
	76	THC	–	–	–	–	–	–	–	–	–	–	–	–	–	–	–
		SHC	–	–	–	–	–	–	–	–	–	–	–	–	–	–	–

– Not operational

THC – Total Cooling Capacity, Gross (1,000 Btuh)

SHC – Sensible Cooling Capacity, Gross (1,000 Btuh)

# PERFORMANCE DATA (cont.)

CAS241 – FAS240

COMBINATION RATINGS

			AMBIENT TEMPERATURE															
			85			95			105			115			125			
			EA (db)			EA (db)			EA (db)			EA (db)			EA (db)			
			75	80	85	75	80	85	75	80	85	75	80	85	75	80	85	
6000 Cfm	EA (wb)	58	THC	221.5	221.5	248.3	213.5	213.5	239.8	204.9	204.9	230.0	195.3	195.3	219.4	184.5	184.5	207.4
		SHC	194.2	221.2	248.3	187.3	213.5	239.8	179.7	204.9	230.0	171.2	195.3	219.4	161.7	184.5	207.4	
	62	THC	232.4	232.4	232.9	222.4	222.4	228.1	211.4	211.4	222.6	199.4	199.4	216.7	186.5	186.5	209.6	
		SHC	173.9	203.4	232.9	169.1	198.6	228.1	163.7	193.2	222.6	157.9	187.3	216.7	151.3	180.5	209.6	
	67	THC	251.7	251.7	251.7	240.8	240.8	240.8	228.9	228.9	228.9	215.9	215.9	215.9	201.6	201.6	201.6	
		SHC	141.6	170.7	199.8	136.8	166.0	195.3	131.7	161.1	190.4	126.2	155.6	185.0	120.3	149.7	179.2	
	72	THC	272.8	272.8	272.8	260.8	260.8	260.8	247.6	247.6	247.6	233.4	233.4	233.4	217.8	217.8	217.8	
		SHC	110.4	138.3	166.1	105.5	133.8	162.0	100.3	128.9	157.5	94.8	123.6	152.4	88.9	117.9	147.0	
	76	THC	–	290.9	290.9	–	278.1	278.1	–	263.7	263.7	–	248.5	248.5	–	231.6	231.6	
		SHC	–	111.5	144.5	–	106.8	139.8	–	103.0	136.0	–	98.3	123.1	–	92.9	120.2	
7000 Cfm	EA (wb)	58	THC	232.1	232.1	260.6	223.5	223.5	251.1	214.2	214.2	240.7	203.9	203.9	229.2	192.4	192.4	216.4
		SHC	203.5	232.1	260.6	195.9	223.5	251.1	187.7	214.2	240.7	178.6	203.9	229.2	168.5	192.4	216.4	
	62	THC	238.9	238.9	253.7	228.3	228.3	248.2	217.1	217.1	242.1	205.0	205.0	234.5	192.8	192.8	222.1	
		SHC	186.0	219.8	253.7	180.8	214.5	248.2	175.1	208.6	242.1	168.4	201.5	234.5	159.1	190.6	222.1	
	67	THC	258.3	258.3	258.3	246.8	246.8	246.8	234.4	234.4	234.4	220.8	220.8	220.8	205.9	205.9	205.9	
		SHC	149.2	182.8	216.5	144.4	178.1	211.8	139.2	173.0	206.7	133.6	167.4	201.2	127.5	161.4	195.3	
	72	THC	279.3	279.3	279.3	266.7	266.7	266.7	253.0	253.0	253.0	238.3	238.3	238.3	222.0	222.0	222.0	
		SHC	113.2	145.9	178.5	108.3	141.2	174.1	103.1	136.3	169.4	97.6	130.9	164.2	91.5	125.1	158.6	
	76	THC	–	297.5	297.5	–	283.8	283.8	–	269.2	269.2	–	253.2	253.2	–	235.5	235.5	
		SHC	–	116.1	154.6	–	112.0	138.2	–	107.4	137.4	–	102.4	133.9	–	96.7	129.1	
8000 Cfm	EA (wb)	58	THC	240.8	240.8	270.6	231.8	231.8	260.5	221.8	221.8	249.4	210.9	210.9	237.2	198.8	198.8	223.6
		SHC	211.0	240.8	270.6	203.0	231.8	260.5	194.2	221.8	249.4	184.6	210.9	237.2	173.9	198.8	223.6	
	62	THC	244.2	244.2	271.9	233.5	233.5	265.4	222.6	222.6	255.7	211.0	211.0	245.3	198.8	198.8	232.0	
		SHC	196.6	234.3	271.9	190.9	228.2	265.4	183.3	219.5	255.7	175.2	210.2	245.3	165.5	198.8	232.0	
	67	THC	263.5	263.5	263.5	251.6	251.6	251.6	238.7	238.7	238.7	224.6	224.6	224.6	209.2	209.2	210.8	
		SHC	156.4	194.4	232.4	151.5	189.6	227.6	146.3	184.4	222.4	140.6	178.7	216.9	134.5	172.6	210.8	
	72	THC	284.4	284.4	284.4	271.3	271.3	271.3	257.3	257.3	257.3	242.0	242.0	242.0	225.4	225.4	225.4	
		SHC	115.9	153.0	190.2	110.9	148.3	185.7	105.8	143.3	180.9	100.2	137.9	175.6	94.2	132.0	169.9	
	76	THC	–	302.5	302.5	–	288.4	288.4	–	273.4	273.4	–	256.8	256.8	–	–	–	
		SHC	–	120.4	153.1	–	116.0	150.4	–	111.3	146.9	–	106.0	142.5	–	–	–	
9000 Cfm	EA (wb)	58	THC	248.2	248.2	279.1	238.7	238.7	268.5	228.3	228.3	256.8	216.8	216.8	244.0	204.1	204.1	229.7
		SHC	217.4	248.2	279.1	209.0	238.7	268.5	199.8	228.3	256.8	189.7	216.8	244.0	178.5	204.1	229.7	
	62	THC	249.3	249.3	285.8	238.9	238.9	277.7	228.3	228.3	266.5	216.8	216.8	253.2	204.1	204.1	238.4	
		SHC	204.9	245.4	285.8	198.4	238.0	277.7	190.1	228.3	266.5	180.4	216.8	253.2	169.8	204.1	238.4	
	67	THC	267.7	267.7	267.7	255.5	255.5	255.5	242.2	242.2	242.2	227.7	227.7	232.0	212.0	212.0	225.6	
		SHC	163.4	205.6	247.7	158.4	200.6	242.9	153.1	195.3	237.6	147.3	189.7	232.0	141.1	183.4	225.6	
	72	THC	288.5	288.5	288.5	275.2	275.2	275.2	260.8	260.8	260.8	245.1	245.1	245.1	228.1	228.1	228.1	
		SHC	118.4	159.9	201.4	113.5	155.2	196.8	108.3	150.1	191.9	102.7	144.6	186.5	96.6	138.7	180.7	
	76	THC	–	306.6	306.6	–	292.3	292.3	–	276.7	276.7	–	–	–	–	–	–	
		SHC	–	124.2	162.9	–	119.7	159.4	–	114.8	155.2	–	–	–	–	–	–	
10,000 Cfm	EA (wb)	58	THC	254.7	254.7	286.5	244.7	244.7	275.3	233.9	233.9	263.2	221.9	221.9	249.8	208.7	208.7	234.9
		SHC	222.9	254.7	286.5	214.1	244.7	275.3	204.6	233.9	263.2	194.0	221.9	249.8	182.5	208.7	234.9	
	62	THC	254.6	254.6	297.3	244.8	244.8	285.3	233.9	233.9	273.1	221.9	221.9	259.2	208.6	208.6	243.8	
		SHC	212.0	254.6	297.3	203.4	244.4	285.3	194.6	233.9	273.1	184.5	221.9	259.2	173.4	208.6	243.8	
	67	THC	271.3	271.3	271.3	258.7	258.7	258.7	245.1	245.1	252.3	230.3	230.3	246.7	214.0	214.0	239.7	
		SHC	170.0	216.4	262.7	165.0	211.4	257.7	159.6	206.0	252.3	153.9	200.3	246.7	147.3	193.5	239.7	
	72	THC	292.0	292.0	292.0	278.4	278.4	278.4	263.7	263.7	263.7	247.4	247.4	247.4	230.0	230.0	230.0	
		SHC	120.9	166.6	212.3	116.0	161.8	207.6	110.7	156.7	202.6	105.0	151.0	197.1	98.9	145.1	191.2	
	76	THC	–	310.1	310.1	–	295.3	295.3	–	–	–	–	–	–	–	–	–	
		SHC	–	127.8	171.4	–	123.2	167.5	–	–	–	–	–	–	–	–	–	

– Not operational

THC – Total Cooling Capacity, Gross (1,000 Btuh)

SHC – Sensible Cooling Capacity, Gross (1,000 Btuh)

# PERFORMANCE DATA (cont.)

CAS241 – FAS300

COMBINATION RATINGS

			AMBIENT TEMPERATURE														
			85			95			105			115			125		
			EA (db)			EA (db)			EA (db)			EA (db)			EA (db)		
			75	80	85	75	80	85	75	80	85	75	80	85	75	80	85
7500 Cfm	58	THC	236.2	236.2	266.2	228.0	228.0	256.9	219.0	219.0	246.7	209.0	209.0	235.5	198.1	198.1	223.2
		SHC	206.3	236.2	266.2	199.0	228.0	256.9	191.2	219.0	246.7	182.5	209.0	235.5	172.9	198.1	223.2
	62	THC	241.6	241.6	264.9	231.6	231.6	259.3	220.9	220.9	252.9	209.4	209.4	244.9	198.2	198.2	231.8
		SHC	191.3	228.1	264.9	186.2	222.8	259.3	180.6	216.7	252.9	173.9	209.4	244.9	164.7	198.2	231.8
	67	THC	262.3	262.3	262.3	251.0	251.0	251.0	238.9	238.9	238.9	225.7	225.7	225.7	211.4	211.4	211.4
		SHC	154.6	192.0	229.4	149.9	187.3	224.6	145.0	182.3	219.6	139.6	176.9	214.2	133.9	171.1	208.4
	72	THC	284.6	284.6	284.6	272.4	272.4	272.4	259.2	259.2	259.2	244.7	244.7	244.7	229.2	229.2	229.2
		SHC	116.2	153.9	191.6	111.6	149.3	186.9	106.8	144.3	181.9	101.5	139.0	176.4	95.9	133.3	170.7
	76	THC	–	303.1	303.1	–	289.9	289.9	–	275.8	275.8	–	260.4	260.4	–	–	–
		SHC	–	123.4	162.7	–	118.8	157.9	–	114.0	152.8	–	108.7	147.3	–	–	–
8750 Cfm	58	THC	247.1	247.1	278.5	238.2	238.2	268.4	228.5	228.5	257.5	217.8	217.8	245.4	206.1	206.1	232.2
		SHC	215.7	247.1	278.5	208.0	238.2	268.4	199.5	228.5	257.5	190.2	217.8	245.4	179.9	206.1	232.2
	62	THC	248.7	248.7	286.9	238.6	238.6	279.1	228.7	228.7	267.4	218.0	218.0	254.9	206.2	206.2	241.2
		SHC	204.5	245.7	286.9	198.2	238.6	279.1	189.9	228.7	267.4	181.1	218.0	254.9	171.3	206.2	241.2
	67	THC	268.2	268.2	268.2	256.5	256.5	256.5	243.9	243.9	243.9	230.1	230.1	234.0	215.3	215.3	227.8
		SHC	164.0	206.9	249.7	159.3	202.1	244.9	154.2	197.0	239.7	148.7	191.4	234.0	142.8	185.3	227.8
	72	THC	290.8	290.8	290.8	277.9	277.9	277.9	264.2	264.2	264.2	249.2	249.2	249.2	233.1	233.1	233.1
		SHC	120.1	163.2	206.3	115.4	158.5	201.5	110.5	153.4	196.4	105.1	148.0	190.9	99.4	142.2	184.9
	76	THC	–	309.2	309.2	–	295.5	295.5	–	280.8	280.8	–	–	–	–	–	–
		SHC	–	128.3	172.8	–	123.7	168.0	–	118.7	162.8	–	–	–	–	–	–
10,000 Cfm	58	THC	255.9	255.9	288.4	246.5	246.5	277.8	236.2	236.2	266.1	224.9	224.9	253.4	212.5	212.5	239.4
		SHC	223.5	255.9	288.4	215.2	246.5	277.8	206.2	236.2	266.1	196.3	224.9	253.4	185.5	212.5	239.4
	62	THC	256.1	256.1	299.5	246.7	246.7	288.4	236.3	236.3	276.4	225.0	225.0	263.1	212.6	212.6	248.6
		SHC	212.7	256.1	299.5	204.9	246.7	288.4	196.3	236.3	276.4	186.9	225.0	263.1	176.6	212.6	248.6
	67	THC	272.9	272.9	272.9	260.7	260.7	264.2	247.7	247.7	258.7	233.6	233.6	252.6	218.5	218.5	245.9
		SHC	173.0	221.1	269.2	168.1	216.1	264.2	162.9	210.8	258.7	157.2	204.9	252.6	151.1	198.5	245.9
	72	THC	295.5	295.5	295.5	282.2	282.2	282.2	268.1	268.1	268.1	252.7	252.7	252.7	236.1	236.1	236.1
		SHC	123.7	172.1	220.4	119.0	167.3	215.5	114.0	162.2	210.3	108.6	156.6	204.7	102.8	150.7	198.6
	76	THC	–	314.0	314.0	–	299.8	299.8	–	–	–	–	–	–	–	–	–
		SHC	–	133.0	182.6	–	128.2	177.7	–	–	–	–	–	–	–	–	–
11,250 Cfm	58	THC	263.3	263.3	296.8	253.4	253.4	285.5	242.6	242.6	273.4	230.7	230.7	260.0	217.7	217.7	245.4
		SHC	229.9	263.3	296.8	221.2	253.4	285.5	211.8	242.6	273.4	201.5	230.7	260.0	190.1	217.7	245.4
	62	THC	263.5	263.5	308.1	253.6	253.6	296.5	242.8	242.8	283.9	230.9	230.9	270.0	217.9	217.9	254.8
		SHC	218.9	263.5	308.1	210.6	253.6	296.5	201.7	242.8	283.9	191.8	230.9	270.0	181.0	217.9	254.8
	67	THC	276.6	276.6	287.7	264.2	264.2	282.3	250.9	250.9	276.5	236.5	236.5	269.8	221.3	221.3	262.1
		SHC	181.4	234.6	287.7	176.4	229.4	282.3	171.1	223.8	276.5	165.2	217.5	269.8	158.6	210.3	262.1
	72	THC	299.3	299.3	299.3	285.7	285.7	285.7	271.2	271.2	271.2	255.4	255.4	255.4	238.5	238.5	238.5
		SHC	127.2	180.6	234.1	122.4	175.7	229.1	117.3	170.6	223.8	111.9	165.0	218.0	106.1	159.0	211.9
	76	THC	–	–	–	–	–	–	–	–	–	–	–	–	–	–	–
		SHC	–	–	–	–	–	–	–	–	–	–	–	–	–	–	–
12,500 Cfm	58	THC	269.7	269.7	303.9	259.3	259.3	292.2	248.1	248.1	279.5	235.7	235.7	265.6	222.2	222.2	250.4
		SHC	235.5	269.7	303.9	226.4	259.3	292.2	216.6	248.1	279.5	205.8	235.7	265.6	194.1	222.2	250.4
	62	THC	269.8	269.8	315.5	259.4	259.4	303.4	248.2	248.2	290.2	235.8	235.8	275.7	222.4	222.4	260.0
		SHC	224.2	269.8	315.5	215.5	259.4	303.4	206.2	248.2	290.2	195.9	235.8	275.7	184.7	222.4	260.0
	67	THC	279.8	279.8	305.1	267.1	267.1	299.3	253.7	253.7	292.8	239.2	239.2	285.1	223.8	223.8	275.5
		SHC	189.4	247.2	305.1	184.3	241.8	299.3	178.6	235.7	292.8	172.3	228.7	285.1	164.9	220.2	275.5
	72	THC	302.4	302.4	302.4	288.5	288.5	288.5	273.7	273.7	273.7	257.7	257.7	257.7	240.4	240.4	240.4
		SHC	130.5	188.9	247.3	125.7	184.0	242.3	120.6	178.7	236.9	115.1	173.1	231.0	109.2	167.0	224.7
	76	THC	–	–	–	–	–	–	–	–	–	–	–	–	–	–	–
		SHC	–	–	–	–	–	–	–	–	–	–	–	–	–	–	–

– Not operational

THC – Total Cooling Capacity, Gross (1,000 Btuh)

SHC – Sensible Cooling Capacity, Gross (1,000 Btuh)

# PERFORMANCE DATA (cont.)

CAS240 – FAS240

COMBINATION RATINGS

			AMBIENT TEMPERATURE															
			85			95			105			115			125			
			EA (db)			EA (db)			EA (db)			EA (db)			EA (db)			
			75	80	85	75	80	85	75	80	85	75	80	85	75	80	85	
6000 Cfm	EA (wb)	58	THC	220.0	220.0	247.0	212.1	212.1	238.2	203.4	203.4	228.5	193.7	193.7	217.7	182.8	182.8	205.5
		SHC	193.0	220.0	247.0	186.0	212.1	238.2	178.3	203.4	228.5	169.8	193.7	217.7	160.1	182.8	205.5	
	62	THC	230.1	230.1	234.9	220.0	220.0	230.0	209.0	209.0	224.6	197.0	197.0	218.3	183.9	183.9	210.5	
		SHC	174.4	204.7	234.9	169.6	199.8	230.0	164.2	194.4	224.6	158.2	188.3	218.3	151.2	180.8	210.5	
	67	THC	251.0	251.0	251.0	239.9	239.9	239.9	227.9	227.9	227.9	214.6	214.6	214.6	199.9	199.9	199.9	
		SHC	142.4	172.3	202.2	137.6	167.6	197.6	132.5	162.6	192.7	126.9	157.1	187.3	120.9	151.1	181.3	
	72	THC	274.2	274.2	274.2	262.0	262.0	262.0	248.7	248.7	248.7	234.1	234.1	234.1	217.9	217.9	217.9	
		SHC	111.3	140.1	168.9	106.4	135.5	164.6	101.2	130.6	160.0	95.6	125.2	154.8	89.5	119.3	149.1	
	76	THC	–	294.4	294.4	–	281.0	281.0	–	266.4	266.4	–	250.7	250.7	–	233.4	233.4	
		SHC	–	113.0	146.0	–	108.7	141.7	–	104.6	133.3	–	99.7	126.2	–	94.1	122.4	
7000 Cfm	EA (wb)	58	THC	230.8	230.8	259.3	222.2	222.2	249.7	212.8	212.8	239.2	202.3	202.3	227.5	190.6	190.6	214.4
		SHC	202.3	230.8	259.3	194.7	222.2	249.7	186.4	212.8	239.2	177.2	202.3	227.5	166.9	190.6	214.4	
	62	THC	236.4	236.4	255.9	225.9	225.9	250.3	215.3	215.3	241.3	203.8	203.8	231.2	191.3	191.3	220.8	
		SHC	186.6	221.3	255.9	181.4	215.8	250.3	174.2	207.7	241.3	166.3	198.7	231.2	158.0	189.4	220.8	
	67	THC	257.6	257.6	257.6	245.9	245.9	245.9	233.2	233.2	233.2	219.3	219.3	219.3	204.0	204.0	204.0	
		SHC	150.4	185.0	219.6	145.5	180.2	214.9	140.3	175.0	209.8	134.6	169.4	204.2	128.4	163.2	198.1	
	72	THC	281.0	281.0	281.0	268.1	268.1	268.1	254.2	254.2	254.2	238.8	238.8	238.8	222.0	222.0	222.0	
		SHC	114.4	148.1	181.8	109.5	143.4	177.3	104.2	138.4	172.5	98.5	132.8	167.2	92.3	126.8	161.3	
	76	THC	–	301.1	301.1	–	287.2	287.2	–	272.2	272.2	–	255.7	255.7	–	–	–	
		SHC	–	118.2	151.3	–	113.9	143.1	–	109.2	140.7	–	104.0	136.6	–	–	–	
8000 Cfm	EA (wb)	58	THC	239.6	239.6	269.4	230.5	230.5	259.2	220.5	220.5	248.0	209.4	209.4	235.6	197.0	197.0	221.7
		SHC	209.9	239.6	269.4	201.8	230.5	259.2	193.0	220.5	248.0	183.3	209.4	235.6	172.3	197.0	221.7	
	62	THC	241.9	241.9	274.0	232.2	232.2	263.9	222.0	222.0	253.2	210.1	210.1	242.3	197.0	197.0	230.1	
		SHC	197.3	235.6	274.0	189.6	226.8	263.9	181.7	217.5	253.2	173.3	207.8	242.3	163.9	197.0	230.1	
	67	THC	262.7	262.7	262.7	250.5	250.5	250.5	237.3	237.3	237.3	222.9	222.9	222.9	207.1	207.1	214.0	
		SHC	158.0	197.1	236.3	153.0	192.2	231.4	147.6	186.9	226.1	141.8	181.1	220.3	135.5	174.7	214.0	
	72	THC	286.3	286.3	286.3	272.8	272.8	272.8	258.4	258.4	258.4	242.5	242.5	242.5	225.1	225.1	225.1	
		SHC	117.4	155.7	194.1	112.4	150.9	189.5	107.1	145.8	184.5	101.3	140.1	179.0	95.1	134.0	173.0	
	76	THC	–	306.6	306.6	–	292.0	292.0	–	276.5	276.5	–	–	–	–	–	–	
		SHC	–	122.8	157.5	–	118.2	154.2	–	113.3	150.2	–	–	–	–	–	–	
9000 Cfm	EA (wb)	58	THC	247.2	247.2	278.0	237.6	237.6	267.3	227.1	227.1	255.5	215.4	215.4	242.4	202.4	202.4	227.8
		SHC	216.4	247.2	278.0	207.9	237.6	267.3	198.7	227.1	255.5	188.4	215.4	242.4	176.9	202.4	227.8	
	62	THC	249.4	249.4	281.3	239.3	239.3	272.2	227.9	227.9	262.4	215.4	215.4	251.6	202.3	202.3	236.4	
		SHC	202.5	241.9	281.3	195.4	233.8	272.2	187.7	225.1	262.4	179.2	215.4	251.6	168.3	202.3	236.4	
	67	THC	266.8	266.8	266.8	254.2	254.2	254.2	240.6	240.6	241.9	225.9	225.9	235.9	209.5	209.5	229.3	
		SHC	165.2	208.8	252.4	160.1	203.8	247.4	154.7	198.3	241.9	148.7	192.3	235.9	142.2	185.7	229.3	
	72	THC	290.4	290.4	290.4	276.6	276.6	276.6	261.8	261.8	261.8	245.4	245.4	245.4	227.6	227.6	227.6	
		SHC	120.1	163.0	205.9	115.1	158.2	201.2	109.8	152.9	196.1	103.9	147.2	190.5	97.6	141.0	184.4	
	76	THC	–	310.7	310.7	–	295.9	295.9	–	–	–	–	–	–	–	–	–	
		SHC	–	126.7	167.1	–	122.1	163.2	–	–	–	–	–	–	–	–	–	
10,000 Cfm	EA (wb)	58	THC	253.7	253.7	285.4	243.7	243.7	274.2	232.7	232.7	261.9	220.5	220.5	248.2	206.9	206.9	233.0
		SHC	221.9	253.7	285.4	213.1	243.7	274.2	203.5	232.7	261.9	192.7	220.5	248.2	180.8	206.9	233.0	
	62	THC	255.5	255.5	290.4	244.0	244.0	282.1	232.6	232.6	271.8	220.5	220.5	257.6	206.9	206.9	241.9	
		SHC	208.4	249.4	290.4	201.5	241.8	282.1	193.5	232.6	271.8	183.3	220.5	257.6	171.9	206.9	241.9	
	67	THC	270.1	270.1	270.1	257.2	257.2	262.7	243.3	243.3	257.0	228.0	228.0	250.8	211.4	211.4	243.3	
		SHC	172.1	220.0	267.8	166.9	214.8	262.7	161.4	209.2	257.0	155.2	203.0	250.8	148.3	195.8	243.3	
	72	THC	293.9	293.9	293.9	279.7	279.7	279.7	264.4	264.4	264.4	247.8	247.8	247.8	229.6	229.6	229.6	
		SHC	122.8	170.1	217.4	117.7	165.1	212.5	112.3	159.8	207.3	106.4	154.0	201.6	100.1	147.8	195.4	
	76	THC	–	314.3	314.3	–	299.1	299.1	–	–	–	–	–	–	–	–	–	
		SHC	–	130.6	175.9	–	125.8	171.7	–	–	–	–	–	–	–	–	–	

– Not operational

THC – Total Cooling Capacity, Gross (1,000 Btuh)

SHC – Sensible Cooling Capacity, Gross (1,000 Btuh)

# PERFORMANCE DATA (cont.)

CAS240 – FAS300

COMBINATION RATINGS

			AMBIENT TEMPERATURE															
			85			95			105			115			125			
			EA (db)			EA (db)			EA (db)			EA (db)			EA (db)			
			75	80	85	75	80	85	75	80	85	75	80	85	75	80	85	
7500 Cfm	EA (wb)	58	THC	237.5	237.5	261.6	228.5	228.5	251.7	218.7	218.7	240.9	207.7	207.7	228.8	195.9	195.9	215.8
		SHC	213.4	237.5	261.6	205.3	228.5	251.7	196.5	218.7	240.9	186.6	207.7	228.8	176.0	195.9	215.8	
	62	THC	241.6	241.6	261.6	230.8	230.8	255.7	220.1	220.1	246.2	207.9	207.9	236.1	196.1	196.1	222.6	
	SHC	201.2	231.4	261.6	195.7	225.7	255.7	188.0	217.1	246.2	179.8	207.9	236.1	169.5	196.1	222.6		
	67	THC	262.2	262.2	262.2	250.1	250.1	250.1	237.0	237.0	237.0	222.5	222.5	222.5	207.4	207.4	207.4	
SHC	163.9	194.6	225.3	158.9	189.6	220.3	153.6	184.2	214.9	147.7	178.3	208.9	141.6	172.2	202.7			
72	THC	285.5	285.5	285.5	272.2	272.2	272.2	257.9	257.9	257.9	242.1	242.1	242.1	225.6	225.6	225.6		
SHC	125.1	156.0	186.9	120.2	151.0	181.9	114.9	145.7	176.5	109.2	139.9	170.6	103.2	133.8	164.5			
76	THC	–	305.5	305.5	–	291.1	291.1	–	–	–	–	–	–	–	–	–		
SHC	–	124.9	156.9	–	120.0	151.8	–	–	–	–	–	–	–	–	–			
8750 Cfm	EA (wb)	58	THC	248.0	248.0	273.2	238.3	238.3	262.5	227.7	227.7	250.8	215.9	215.9	237.8	203.3	203.3	223.9
		SHC	222.8	248.0	273.2	214.1	238.3	262.5	204.6	227.7	250.8	194.0	215.9	237.8	182.6	203.3	223.9	
	62	THC	249.2	249.2	280.0	238.6	238.6	270.9	227.9	227.9	258.8	216.1	216.1	245.4	203.4	203.4	231.0	
	SHC	213.6	246.8	280.0	206.3	238.6	270.9	197.0	227.9	258.8	186.8	216.1	245.4	175.8	203.4	231.0		
	67	THC	267.7	267.7	267.7	254.9	254.9	254.9	241.2	241.2	241.2	226.3	226.3	228.3	210.6	210.6	221.6	
SHC	174.8	210.1	245.4	169.7	204.9	240.2	164.2	199.3	234.5	158.2	193.2	228.3	151.8	186.7	221.6			
72	THC	291.3	291.3	291.3	277.3	277.3	277.3	262.4	262.4	262.4	246.1	246.1	246.1	228.9	228.9	228.9		
SHC	130.3	165.7	201.2	125.2	160.6	196.0	119.9	155.2	190.5	114.0	149.2	184.4	108.0	143.1	178.1			
76	THC	–	311.4	311.4	–	–	–	–	–	–	–	–	–	–	–	–		
SHC	–	130.1	166.5	–	–	–	–	–	–	–	–	–	–	–	–			
10,000 Cfm	EA (wb)	58	THC	256.5	256.5	282.5	246.1	246.1	271.1	234.9	234.9	258.8	222.4	222.4	245.0	209.1	209.1	230.4
		SHC	230.4	256.5	282.5	221.2	246.1	271.1	211.1	234.9	258.8	199.9	222.4	245.0	187.9	209.1	230.4	
	62	THC	256.7	256.7	291.5	246.3	246.3	279.7	235.1	235.1	267.0	222.6	222.6	252.8	209.3	209.3	237.6	
	SHC	221.9	256.7	291.5	213.0	246.3	279.7	203.2	235.1	267.0	192.4	222.6	252.8	180.9	209.3	237.6		
	67	THC	271.7	271.7	271.7	258.6	258.6	259.0	244.6	244.6	253.0	229.2	229.2	246.3	213.3	213.3	238.9	
SHC	185.1	224.9	264.6	179.8	219.4	259.0	174.1	213.6	253.0	167.8	207.1	246.3	161.1	200.0	238.9			
72	THC	295.6	295.6	295.6	281.2	281.2	281.2	265.8	265.8	265.8	249.0	249.0	249.0	–	–	–		
SHC	135.2	175.0	214.9	130.0	169.8	209.6	124.6	164.2	203.9	118.6	158.2	197.7	–	–	–			
76	THC	–	–	–	–	–	–	–	–	–	–	–	–	–	–	–		
SHC	–	–	–	–	–	–	–	–	–	–	–	–	–	–	–			
11,250 Cfm	EA (wb)	58	THC	263.5	263.5	290.3	252.7	252.7	278.3	240.9	240.9	265.3	227.9	227.9	251.0	214.0	214.0	235.7
		SHC	236.8	263.5	290.3	227.0	252.7	278.3	216.4	240.9	265.3	204.7	227.9	251.0	192.2	214.0	235.7	
	62	THC	263.7	263.7	299.5	252.9	252.9	287.1	241.1	241.1	273.7	228.0	228.0	258.9	214.1	214.1	243.1	
	SHC	228.0	263.7	299.5	218.6	252.9	287.1	208.4	241.1	273.7	197.1	228.0	258.9	185.1	214.1	243.1		
	67	THC	275.0	275.0	282.7	261.6	261.6	276.8	247.2	247.2	270.3	231.8	231.8	262.6	216.0	216.0	251.8	
SHC	194.9	238.8	282.7	189.4	233.1	276.8	183.4	226.8	270.3	176.6	219.6	262.6	168.2	210.0	251.8			
72	THC	299.0	299.0	299.0	284.2	284.2	284.2	268.4	268.4	268.4	251.3	251.3	251.3	–	–	–		
SHC	139.8	184.0	228.1	134.6	178.7	222.7	129.0	173.0	216.9	123.1	166.8	210.6	–	–	–			
76	THC	–	–	–	–	–	–	–	–	–	–	–	–	–	–	–		
SHC	–	–	–	–	–	–	–	–	–	–	–	–	–	–	–			
12,500 Cfm	EA (wb)	58	THC	269.5	269.5	296.9	258.2	258.2	284.4	245.9	245.9	270.9	232.4	232.4	256.0	218.0	218.0	240.1
		SHC	242.2	269.5	296.9	232.0	258.2	284.4	221.0	245.9	270.9	208.8	232.4	256.0	195.9	218.0	240.1	
	62	THC	269.7	269.7	306.3	258.4	258.4	293.4	246.1	246.1	279.4	232.5	232.5	264.0	218.1	218.1	247.6	
	SHC	233.2	269.7	306.3	223.4	258.4	293.4	212.8	246.1	279.4	201.0	232.5	264.0	188.6	218.1	247.6		
	67	THC	277.8	277.8	299.7	264.1	264.1	293.2	249.7	249.7	285.6	234.5	234.5	274.3	218.8	218.8	261.2	
SHC	204.0	251.8	299.7	198.2	245.7	293.2	191.6	238.6	285.6	183.1	228.7	274.3	173.4	217.3	261.2			
72	THC	301.7	301.7	301.7	286.6	286.6	286.6	270.5	270.5	270.5	–	–	–	–	–	–		
SHC	144.3	192.6	241.0	139.0	187.2	235.5	133.4	181.5	229.6	–	–	–	–	–	–			
76	THC	–	–	–	–	–	–	–	–	–	–	–	–	–	–	–		
SHC	–	–	–	–	–	–	–	–	–	–	–	–	–	–	–			

– Not operational

THC – Total Cooling Capacity, Gross (1,000 Btuh)

SHC – Sensible Cooling Capacity, Gross (1,000 Btuh)



# ELECTRICAL DATA

## CAS072\*(A,B) COOLING WITHOUT POWERED CONVENIENCE OUTLET

(Units Produced On or After 02/09/2015)

V-Ph-Hz	VOLTAGE RANGE		COMP 1		OFM (ea)		POWER SUPPLY	
	MIN	MAX	RLA	LRA	WATTS	FLA	MCA	Fuse
208/230-3-60	187	253	19.6	136	325	1.5	28/28	45/45
460-3-60	414	506	8.2	66	325	0.8	12	20
575-3-60	518	633	6.6	55	325	0.7	10	15

(Units Produced on or Prior to 02/08/2015)

V-Ph-Hz	VOLTAGE RANGE		COMP 1		OFM (ea)		POWER SUPPLY	
	MIN	MAX	RLA	LRA	WATTS	FLA	MCA	Fuse
208/230-3-60	187	253	19.0	123	325	1.5	27/27	45/45
460-3-60	414	506	9.7	62	325	0.8	14	20
575-3-60	518	633	7.4	50	325	0.7	11	15

## CAS072\*(G,H) COOLING WITHOUT POWERED CONVENIENCE OUTLET

V-Ph-Hz	VOLTAGE RANGE		COMP 1		OFM (ea)		POWER SUPPLY	
	MIN	MAX	RLA	LRA	WATTS	FLA	MCA	Fuse
208/230-3-60	187	253	17.5	136	325	1.5	25/25	30/30
460-3-60	414	506	8.4	66	325	0.8	13	20
575-3-60	518	633	6.3	55	325	0.7	10	15

## CAS091\*(A,B) COOLING WITHOUT POWERED CONVENIENCE OUTLET

V-Ph-Hz	VOLTAGE RANGE		COMP 1		OFM (ea)		POWER SUPPLY	
	MIN	MAX	RLA	LRA	WATTS	FLA	MCA	Fuse
208/230-3-60	187	253	25	164	325	1.5	34.3	50
460-3-60	414	506	12.2	100	325	0.8	16.9	25
575-3-60	518	633	9.0	78	325	0.7	12.7	20

## CAS091\*(G,H) COOLING WITHOUT POWERED CONVENIENCE OUTLET

V-Ph-Hz	VOLTAGE RANGE		COMP 1		OFM (ea)		POWER SUPPLY	
	MIN	MAX	RLA	LRA	WATTS	FLA	MCA	Fuse
208/230-3-60	187	253	24	164	325	1.5	33/33	50/50
460-3-60	414	506	12.6	100	325	0.8	18	25
575-3-60	518	633	9.9	78	325	0.7	14	20

## CAS121 COOLING WITHOUT POWERED CONVENIENCE OUTLET

V-Ph-Hz	VOLTAGE RANGE		COMP 1		OFM (ea)		POWER SUPPLY	
	MIN	MAX	RLA	LRA	WATTS	FLA	MCA	Fuse
208/230-3-60	187	253	30.1	225	325	1.5	40.6	60
460-3-60	414	506	16.7	114	325	0.8	22.5	30
575-3-60	518	633	12.2	80	325	0.7	16.7	25

## CAS120 COOLING WITHOUT POWERED CONVENIENCE OUTLET

V-Ph-Hz	VOLTAGE RANGE		COMP 1		COMP 2		OFM (ea)		POWER SUPPLY	
	MIN	MAX	RLA	LRA	RLA	LRA	WATTS	FLA	MCA	Fuse
208/230-3-60	187	253	15.9	110	15.9	110	325	1.5	38.8	50
460-3-60	414	506	7.7	52	7.7	52	325	0.8	18.9	25
575-3-60	518	633	5.7	39	5.7	39	325	0.7	14.2	20

## CAS151 COOLING WITHOUT POWERED CONVENIENCE OUTLET

V-Ph-Hz	VOLTAGE RANGE		COMP 1		OFM (ea)		POWER SUPPLY	
	MIN	MAX	RLA	LRA	WATTS	FLA	MCA	Fuse
208/230-3-60	187	253	48.1	245	325	1.5	63.1	80
460-3-60	414	506	18.6	125	325	0.8	24.9	30
575-3-60	518	633	14.7	100	325	0.7	19.8	30

## CAS150 COOLING WITHOUT POWERED CONVENIENCE OUTLET

V-Ph-Hz	VOLTAGE RANGE		COMP 1		COMP 2		OFM (ea)		POWER SUPPLY	
	MIN	MAX	RLA	LRA	RLA	LRA	WATTS	FLA	MCA	Fuse
208/230-3-60	187	253	22.40	149	22.40	149	325	1.5	53.4	60
460-3-60	414	506	10.6	75	10.6	75	325	0.8	25.5	30
575-3-60	518	633	7.7	54	7.7	54	325	0.7	18.7	25

## ELECTRICAL DATA (cont.)

### CAS181 COOLING WITHOUT POWERED CONVENIENCE OUTLET

V-Ph-Hz	VOLTAGE RANGE		COMP 1		COMP 2		OFM (ea)		POWER SUPPLY	
	MIN	MAX	RLA	LRA	RLA	LRA	WATTS	FLA	MCA	Fuse
208/230-3-60	187	253	25	164	25	164	325	1.5	60.8	80
460-3-60	414	506	12.2	100	12.2	100	325	0.8	29.9	40
575-3-60	518	633	9	78	9	78	325	0.7	22.4	30

### CAS180 COOLING WITHOUT POWERED CONVENIENCE OUTLET

V-Ph-Hz	VOLTAGE RANGE		COMP 1		COMP 2		OFM (ea)		POWER SUPPLY	
	MIN	MAX	RLA	LRA	RLA	LRA	WATTS	FLA	MCA	Fuse
208/230-3-60	187	253	25	164	25	164	325	1.5	60.7	80
460-3-60	414	506	12.2	100	12.2	100	325	0.8	29.8	40
575-3-60	518	633	9	78	9	78	325	0.6	22.0	30

### CAS241 COOLING WITHOUT POWERED CONVENIENCE OUTLET

V-Ph-Hz	VOLTAGE RANGE		COMP 1		COMP 2		OFM (ea)		POWER SUPPLY	
	MIN	MAX	RLA	LRA	RLA	LRA	WATTS	FLA	MCA	Fuse
208/230-3-60	187	253	30.1	225	30.1	225	325	1.5	73.7	100
460-3-60	414	506	16.7	114	16.7	114	325	0.8	40.8	50
575-3-60	518	633	12.2	80	12.2	80	325	0.7	30.3	40

### CAS240 COOLING WITHOUT POWERED CONVENIENCE OUTLET

V-Ph-Hz	VOLTAGE RANGE		COMP 1		COMP 2		OFM (ea)		POWER SUPPLY	
	MIN	MAX	RLA	LRA	RLA	LRA	WATTS	FLA	MCA	Fuse
208/230-3-60	187	253	30.1	225	30.1	225	325	1.5	73.7	100
460-3-60	414	506	16.7	114	16.7	114	325	0.8	40.8	50
575-3-60	518	633	12.2	80	12.2	80	325	0.7	30.3	40

# APPLICATION DATA

## Operating limits

Maximum outdoor temperature ..... 125°F  
 Minimum return-air temperature (FAS) ..... 55°F  
 Maximum return-air temperature (FAS) ..... 95°F  
 Range of acceptable saturation  
     suction temperature ..... 20 to 50°F  
 Maximum discharge temperature ..... 275°F  
 Minimum discharge superheat ..... 60°F

### NOTES:

1. Select air handler at no less than 300 cfm/ton (nominal condensing unit capacity).
2. Total combined draw of the field-supplied liquid line solenoid valve and air handler fan contactor must not exceed 22 va. If the specified va must be exceeded, use a remote relay to control the load.

## Refrigerant piping

**IMPORTANT:** Do not bury refrigerant piping underground.

It is recommended that the refrigerant piping for all commercial split systems include a liquid line solenoid valve, a liquid line filter drier and a sight glass.

## MINIMUM OUTDOOR-AIR OPERATING TEMPERATURE

UNIT CAS	MINIMUM OUTDOOR TEMP (°F)	
	Std	With MotorMaster I® Control†
072	35	-20
091	35	
121	35	
151	35	
181	35	
241	35	
120	35	
150	35	
180	35	
240	35	

† Wind baffles (field-supplied and field-installed) are recommended for all units with MotorMaster I® control. Refer to Low Ambient Temperature Control Installation Instructions for additional information.

For refrigerant lines longer than 75 lineal ft, a liquid line solenoid valve installed at the **indoor** unit and a suction accumulator are required. Refer to the Refrigerant Specialties Part Numbers table.

## REFRIGERANT SPECIALTIES PART NUMBERS

LIQUID LINE SIZE (in.)	LIQUID LINE SOLENOID VALVE (LLSV)	LLSV COIL	SIGHT GLASS
3/8	1179871	1179874	1179879
1/2	1179872	1179874	1179877
5/8	1179873	1179874	1179878

**NOTE:** CAS units require TWO sets of parts.

## R-410A Filter Drier(s)

Model-Size	Qty	Liquid Line OD	Desiccant Volume	Part Number Ref
CAS*072	1	3/8-in	8 cu. in.	1179878
CAS*091	1	1/2-in	16 cu. in.	1179538
CAS*121	1	1/2-in	16 cu. in.	1179538
CAS*151	1	5/8-in	16 cu. in.	1179558
CAS*181	1	5/8-in	30 cu. in.	1179552
CAS*241	1	5/8-in	30 cu. in.	1179552
CAS*120	2	3/8-in	8 cu. in.	1179492
CAS*150	2	1/2-in	16 cu. in.	1179538
CAS*180	2	1/2-in	16 cu. in.	1179538
CAS*240	2	1/2-in	16 cu. in.	1179538

**CAS 072-151 PIPING RECOMMENDATIONS (SINGLE-CIRCUIT UNIT)**

Model & Nominal Capacity	Linear Line (ft)	0 - 25	25 - 50	50 - 75	75 - 100	100 - 125	125 - 150	150 - 175	175 - 200							
	Linear Line (m)	0 - 8	8 - 15	15 - 23	23 - 30	30 - 38	38 - 46	46 - 53	53 - 61							
	Equivalent Line (ft)	0 - 38	38 - 75	75 - 113	113 - 150	150 - 188	188 - 225	225 - 263	263 - 300							
	Equivalent Line (m)	0 - 12	12 - 23	23 - 34	34 - 46	46 - 57	57 - 69	69 - 80	80 - 91							
CAS072 TC 68.5 SC 5.6F	Liquid Line size	3/8"	3/8"	1/2"	1/2"	5/8"	1/2"	5/8"	1/2"	5/8"	1/2"	5/8"	1/2"	5/8"	1/2"	5/8"
	Liquid PD (F)	2.0	4.0	0.7	1.1	0.3	1.4	0.4	1.8	0.5	2.1	0.6	2.5	0.7	2.8	0.8
	Max Lift	18	7	34	31	39	44	57	41	57	35	54	31	53	27	52
	Max Lift PD (F)	3.5	4.6	3.5	3.5	3.5	5.0	5.0	5.0	5.0	4.9	5.0	5.0	5.0	5.0	5.0
	Suction Line size	7/8"	7/8"	1 1/8"	7/8"	1 1/8"	7/8"	1 1/8"	7/8"	1 1/8"	1 1/8"	1 1/8"	1 1/8"	1 1/8"	1 1/8"	1 1/8"
	Suction Line PD (F)	0.9	1.8	0.5	2.7	0.8	3.6	1.0	4.5	1.3	1.6	1.8	2.1	2.1	2.1	2.1
	Charge	10.8	11.8	13.7	15.2	18.5	16.9	21.3	18.7	24.2	21.4	27.1	23.4	30.0	25.3	32.8
	#TR	1.90	2.07	2.41	2.67	3.25	2.97	3.74	3.28	4.25	3.8	4.75	4.1	5.26	4.4	5.75
	CAS091 (A,B) TC 91.9 SC 11.8F	Liquid Line size	1/2"	1/2"	5/8"	1/2"	5/8"	1/2"	5/8"	1/2"	5/8"	1/2"	5/8"	1/2"	5/8"	1/2"
Liquid PD (F)		0.6	1.3	0.3	1.9	0.5	2.5	0.7	3.2	0.9	3.8	1.0	4.4	1.2	5.1	1.4
Max Lift		25	50	50	75	75	100	100	97	97	90	90	82	121	74	119
Max Lift PD (F)		2.7	5.4	4.5	8.1	6.7	10.8	9.0	11.2	8.9	11.2	8.5	11.2	11.2	11.2	11.2
Suction Line size		7/8"	7/8"	1 1/8"	7/8"	1 1/8"	1 1/8"	1 1/8"	1 1/8"	1 3/8"	1 1/8"	1 3/8"	1 1/8"	1 3/8"	1 1/8"	1 3/8"
Suction Line PD (F)		1.5	3.1	0.8	4.6	1.2	1.6	2.1	0.7	2.5	0.8	2.9	1.0	3.3	1.1	
Charge		13.6	15.4	16.1	17.2	20.5	19.5	23.3	21.5	27.1	23.4	30.2	25.4	33.2	27.3	36.3
#TR		1.78	2.02	2.11	2.25	2.68	2.55	3.05	2.81	3.54	3.06	3.95	3.32	4.34	3.57	4.75
CAS091 (D,E) TC 92.0 SC 11.3F		Liquid Line size	1/2"	1/2"	5/8"	1/2"	5/8"	1/2"	5/8"	1/2"	5/8"	1/2"	5/8"	1/2"	5/8"	1/2"
	Liquid PD (F)	0.6	1.3	0.3	1.9	0.5	2.5	0.7	3.2	0.9	3.8	1.0	4.4	1.2	5.1	1.4
	Max Lift	25	50	50	75	75	100	100	97	97	90	90	82	121	74	119
	Max Lift PD (F)	2.7	5.4	4.5	8.1	6.7	10.8	9.0	11.2	8.9	11.2	8.5	11.2	11.2	11.2	11.2
	Suction Line size	7/8"	7/8"	1 1/8"	7/8"	1 1/8"	1 1/8"	1 1/8"	1 1/8"	1 3/8"	1 1/8"	1 3/8"	1 1/8"	1 3/8"	1 1/8"	1 3/8"
	Suction Line PD (F)	1.5	3.1	0.8	4.6	1.2	1.6	2.1	0.7	2.5	0.8	2.9	1.0	3.3	1.1	
	Charge	15.0	18.4	19.1	20.2	23.5	22.5	26.3	24.5	30.1	25.4	32.2	26.4	34.2	27.3	36.5
	#TR	1.78	2.02	2.11	2.25	2.68	2.55	3.05	2.81	3.54	3.06	3.95	3.32	4.34	3.57	4.75
	CAS121 TC 113.1 SC 7.1F	Liquid Line size	1/2"	1/2"	5/8"	1/2"	5/8"	1/2"	5/8"	1/2"	5/8"	1/2"	5/8"	5/8"	5/8"	5/8"
Liquid PD (F)		0.9	1.9	0.5	2.8	0.8	3.8	1.0	4.7	1.3	5.7	1.6	1.8	2.1		
Max Lift		25	40	50	28	54	34	68	22	65	11	63	59	55		
Max Lift PD (F)		2.9	5.0	4.5	5.0	5.0	6.5	6.4	6.5	6.4	6.5	6.5	6.4	6.4		
Suction Line size		7/8"	7/8"	1 1/8"	1 1/8"	1 3/8"	1 1/8"	1 3/8"	1 1/8"	1 3/8"	1 1/8"	1 3/8"	1 1/8"	1 3/8"	1 1/8"	1 3/8"
Suction Line PD (F)		2.4	4.8	1.2	1.8	0.6	2.4	0.9	3.1	1.1	3.7	1.3	4.3	1.5	4.9	1.7
Charge		15.7	17.5	19.7	19.8	23.1	21.6	26.1	23.6	29.2	25.5	32.3	34.1	35.3	36.9	38.4
#TR		1.67	1.86	2.09	2.10	2.45	2.29	2.77	2.50	3.10	2.71	3.43	3.62	3.75	3.92	4.08
CAS151 TC 146.1 SC 3.9F		Liquid Line size	5/8"	5/8"	3/4"	5/8"	3/4"	5/8"	3/4"	5/8"	3/4"	5/8"	3/4"	5/8"	3/4"	3/4"
	Liquid PD (F)	0.4	0.8	0.4	1.2	0.6	1.6	0.8	2.0	1.1	2.4	1.1	2.8	1.5	1.7	0.6
	Max Lift	23	16	23	10	18	28	38	21	36	14	35	9	30	25	43
	Max Lift PD (F)	1.8	1.84	1.84	1.8	1.8	3.3	3.3	3.3	3.3	3.3	3.3	3.3	3.3	3.3	3.3
	Suction Line size	1 1/8"	1 1/8"	1 3/8"	1 1/8"	1 3/8"	1 3/8"	1 3/8"	1 3/8"	1 5/8"	1 3/8"	1 5/8"	1 3/8"	1 5/8"	1 3/8"	1 5/8"
	Suction Line PD (F) (Cap Red)	1.1	2.2	0.8	3.3 (-2.3%)	1.2	1.6	2.0	0.8	2.4 (-0.7%)	1.0	2.8 (-1.4%)	1.2	3.2 (-2.1%)	1.3	
	Charge	31.8	34.7	37.6	37.6	41.8	41.1	46.1	44.2	51.6	47.3	56.1	50.3	60.6	63.4	76.9
	#TR	2.62	2.86	3.09	3.09	3.44	3.38	3.79	3.64	4.24	3.89	4.61	4.14	4.98	5.21	6.32

<b>Legend:</b>	
TC	Total Capacity, MBH (at 45°F Saturated suction, 95°F outdoor air temp)
SC	Sub-cooling, degrees F (at liquid line valve)
Equivalent Length	Equivalent tubing length, including effects of refrigeration specialties devices
Linear Length	Linear tubing length, feet
Liquid Line size	Tubing size, inches OD.
Liquid PD (F)	Liquid line pressure drop, saturated temperature, degrees F
Max Lift	Maximum liquid lift (indoor unit ABOVE outdoor unit only), at maximum permitted liquid line pressure drop
Suction Line size	Tube size, inches OD
Suction Line (PD) (F)	Suction line pressure drop, saturated temperature, degree F
(Cap Red)	Capacity reduction caused by suction line pressure drop GT 2 deg F
Charge	Charge Quantity, lbs. Calculated for both liquid line sizes (where applicable), but only with larger suction line size (where applicable)
#TR	Charge to unit capacity ratio, lbs per ton (at 45 F SST, 95 F ODA)

**CAS 181-241 PIPING RECOMMENDATIONS (SINGLE-CIRCUIT UNIT)**

Model & Nominal Capacity	Linear Line (ft)	0 - 25	25 - 50	50 - 75	75 - 100	100 - 125	125 - 150	150 - 175	175 - 200						
	Linear Line (m)	0 - 8	8 - 15	15 - 23	23 - 30	30 - 38	38 - 46	46 - 53	53 - 61						
	Equivalent Line (ft)	0 - 38	38 - 75	75 - 113	113 - 150	150 - 188	188 - 225	225 - 263	263 - 300						
	Equivalent. Line (m)	0 - 12	12 - 23	23 - 34	34 - 46	46 - 57	57 - 69	69 - 80	80 - 91						
CAS181 TC 185.7 SC 18.4F	Liquid Line size	5/8"	5/8"	5/8"	5/8"	5/8"	5/8"	5/8"	3/4"	5/8"	3/4"				
	Liquid PD (F)	0.7	1.3	2.0	2.7	3.4	4.0	4.7	2.5	5.4	2.8				
	Max Lift	25	50	75	100	125	150	153	175	145	175				
	Max Lift PD (F)	2.8	5.65	8.5	11.3	14.1	16.9	17.9	17.5	17.9	17.9				
	Suction Line size	1 3/8"	1 3/8"	1 3/8"	1 3/8"	1 3/8"	1 5/8"	1 3/8"	1 5/8"	1 3/8"	1 5/8"	1 5/8"			
	Suction Ln PD(F) (Cap Red)	1.4	1.0	1.5	2.0	2.5 (-0.9%)	1.1	3 (-1.8%)	1.3	3.5 (-2.7%)	1.5	4 (-3.6%)	1.7		
	Charge	35.1	38.1	41.2	44.2	47.3	48.4	50.4	51.7	53.4	63.7	56.5	68.3		
	#/TR	2.9	3.11	3.36	3.61	3.86	3.95	4.11	4.22	4.36	5.20	4.61	5.57		
	CAS241 TC 233.3 SC 13.0F	Liquid Line size	5/8"	5/8"	5/8"	5/8"	5/8"	3/4"	5/8"	3/4"	5/8"	3/4"	5/8"	3/4"	
Liquid PD (F)		1.1	2.1	3.2	4.3	5.4	2.8	6.4	3.3	7.5	3.9	8.6	4.4		
Max Lift		25	50	93	98	85	116	71	108	59	102	46	95		
Max Lift PD (F)		3.2	6.4	9.6	12.5	12.5	12.5	12.4	12.5	12.5	12.5	12.5	12.5		
Suction Line size		1 3/8"	1 3/8"	1 3/8"	1 5/8"	1 3/8"	1 5/8"	1 3/8"	1 5/8"	2 1/8"	1 5/8"	2 1/8"	1 5/8"	2 1/8"	
Suction Ln PD(F) (Cap Red)		0.8	1.6	2.4 (-0.8%)	1.0	3.3 (-2.2%)	1.4	4 (-3.6%)	1.7	2.0	0.4	2.4 (-0.7%)	0.5	2.7 (-1.2%)	0.6
Charge		31.1	34.1	37.2	37.9	40.2	41.1	43.3	50.7	47.7	58.5	51.0	63.6	54.3	68.7
#/TR		2.52	2.77	3.02	3.07	3.26	3.34	3.51	4.11	3.87	4.75	4.13	5.16	4.40	5.57

<b>Legend:</b>	
TC	Total Capacity, MBH (at 45°F Saturated suction, 95°F outdoor air temp)
SC	Sub-cooling, degrees F (at liquid line valve)
Equivalent Length	Equivalent tubing length, including effects of refrigeration specialties devices
Linear Length	Linear tubing length, feet
Liquid Line size	Tubing size, inches OD.
Liquid PD (F)	Liquid line pressure drop, saturated temperature, degrees F
Max Lift	Maximum liquid lift (indoor unit ABOVE outdoor unit only), at maximum permitted liquid line pressure drop
Suction Line size	Tube size, inches OD
Suction Line (PD) (F) (Cap Red)	Suction line pressure drop, saturated temperature, degree F Capacity reduction caused by suction line pressure drop GT 2 deg F
Charge	Charge Quantity, lbs. Calculated for both liquid line sizes (where applicable), but only with larger suction line size (where applicable)
#/TR	Charge to unit capacity ratio, lbs per ton (at 45 F SST, 95 F ODA)

**CAS 120-240 PIPING RECOMMENDATIONS (TWO-CIRCUIT UNIT)**

**NOTE:** CAS units requires TWO sets of refrigeration piping

Model & Nominal Capacity	Linear Line (ft)	0 - 25	25 - 50	50 - 75	75 - 100	100 - 125	125 - 150	150 - 175	175 - 200						
	Linear Line (m)	0 - 8	8 - 15	15 - 23	23 - 30	30 - 38	38 - 46	46 - 53	53 - 61						
	Equivalent Line (ft)	0 - 38	38 - 75	75 - 113	113 - 150	150 - 188	188 - 225	225 - 263	263 - 300						
	Equivalent Line (m)	0 - 12	12 - 23	23 - 34	34 - 46	46 - 57	57 - 69	69 - 80	80 - 91						
CAS120 TC 55.9 Each SC 12.7F	Liquid Line size	3/8"	3/8"	3/8"	3/8"	1/2"	3/8"	1/2"	3/8"	1/2"	5/8"	1/2"	5/8"		
	Liquid PD (F)	1.4	2.7	5.5	5.5	0.9	6.9	1.1	8.2	1.4	1.6	0.5	1.8	0.5	
	Max Lift	25	50	75	82	100	66	125	49	133	130	144	128	144	
	Max Lift PD (F)	3.4	6.8	10.2	12.1	9.0	12.1	11.2	12.1	12.1	12.1	12.1	12.1	12.1	
	Suction Line size	3/4"	7/8"	7/8"	7/8"	1 1/8"	7/8"	1 1/8"	1 1/8"	1 1/8"	1 1/8"	1 1/8"	1 1/8"	1 1/8"	
	Suction Ln PD (F) (Cap Red)	1.4	1.2	1.8	2.5 (-0.8%)	0.8	3.1 (-1.9%)	0.9	1.1	1.3	1.3	1.3	1.3	1.5	
	Charge	9.0	10.0	11.0	12.1	15.7	13.1	17.7	14.9	19.6	21.5	28.2	23.5	31.0	
	#/TR	0.73	0.81	0.89	0.97	1.27	1.05	1.42	1.20	1.58	1.74	2.27	1.89	2.50	
CAS150 TC 69.8 Each SC 14.2F	Liquid Line size	3/8"	3/8"	3/8"	3/8"	1/2"	3/8"	1/2"	1/2"	1/2"	5/8"	1/2"	5/8"		
	Liquid PD (F)	2.1	4.1	6.2	8.2	1.5	10.3	1.8	2.2	2.6	0.7	2.9	0.8		
	Max Lift	128	50	75	69	155	42	125	145	140	163	135	162		
	Max Lift PD (F)	4.0	8.1	12.1	13.6	9.4	13.6	11.7	13.6	13.6	13.6	13.6	13.6		
	Suction Line size	7/8"	7/8"	7/8"	1 1/8"	1 1/8"	1 1/8"	1 1/8"	1 1/8"	1 1/8"	1 1/8"	1 1/8"	1 1/8"		
	Suction Ln PD (F) (Cap Red)	1.0	1.9	2.9 (-1.5%)	0.8	1.1	1.4	1.6	1.6	1.9	1.9	2.2 (-0.3%)	0.7		
	Charge	17.0	18.0	19.0	19.5	20.6	23.7	21.8	25.7	27.6	29.5	36.2	31.5	39.0	
	#/TR	1.36	1.44	1.52	1.56	1.65	1.90	1.74	2.05	2.21	2.36	2.89	2.52	3.12	
CAS180 TC 92.9 Each SC 15.1F	Liquid Line size	3/8"	3/8"	3/8"	1/2"	1/2"	1/2"	1/2"	5/8"	1/2"	5/8"	1/2"	5/8"		
	Liquid PD (F)	3.4	6.9	10.3	1.9	2.6	3.2	3.9	1.0	4.5	1.2	5.1	1.4		
	Max Lift	25	50	32	75	144	125	127	150	121	159	112	157		
	Max Lift PD (F)	5.5	11.1	13.0	8.2	10.9	13.7	14.5	13.6	14.5	14.5	14.5	14.5		
	Suction Line size	7/8"	7/8"	1 1/8"	1 1/8"	1 1/8"	1 1/8"	1 3/8"	1 1/8"	1 3/8"	1 1/8"	1 3/8"	1 1/8"		
	Suction Ln PD (F) (Cap Red)	1.5	3.1 (-1.9%)	0.8	1.2	1.6	2	0.7	2.5	0.8	2.9 (-1.5%)	1.0	3.3 (-2.2%)	1.1	
	Charge	17.0	18.0	18.3	19.5	21.8	23.7	25.7	26.6	27.6	34.4	29.5	37.4	31.5	40.5
	#/TR	1.35	1.43	1.46	1.55	1.73	1.89	2.04	2.11	2.19	2.73	2.35	2.97	2.50	3.22
CAS240 TC 121.2 Each SC 10.6F	Liquid Line size	3/8"	1/2"	1/2"	5/8"	1/2"	5/8"	1/2"	5/8"	1/2"	5/8"	5/8"	5/8"	3/4"	
	Liquid PD (F)	5.6	2.2	3.3	0.9	4.3	1.2	5.4	1.5	6.5	1.8	2.1	2.4	1.3	
	Max Lift	25	50	64	75	70	108	55	104	42	100	97	92	107	
	Max Lift PD (F)	7.7	6.3	8.5	7.1	10.0	9.4	9.9	10.0	10.0	10.0	10.0	9.9	10.0	
	Suction Line size	1 1/8"	1 1/8"	1 1/8"	1 3/8"	1 1/8"	1 3/8"	1 1/8"	1 3/8"	1 3/8"	1 3/8"	1 3/8"	1 3/8"	1 3/8"	
	Suction Line PD (F) (Cap Red)	0.7	1.3	2.0	0.7	2.7 (-1.2%)	1.0	3.4 (-2.4%)	1.2	1.4	1.4	1.7	1.7	1.9	
	Charge	15.2	17.9	19.8	23.2	21.7	26.2	23.7	29.3	26.7	32.4	35.4	38.5	48.5	
	#/TR	1.20	1.41	1.56	1.83	1.72	2.07	1.87	2.31	2.11	2.56	2.80	3.04	3.83	

<b>Legend:</b>	
TC	Total Capacity, MBH (at 45°F Saturated suction, 95°F outdoor air temp)
SC	Sub-cooling, degrees F (at liquid line valve)
Equivalent Length	Equivalent tubing length, including effects of refrigeration specialties devices
Linear Length	Linear tubing length, feet
Liquid Line size	Tubing size, inches OD.
Liquid PD (F)	Liquid line pressure drop, saturated temperature, degrees F
Max Lift	Maximum liquid lift (indoor unit ABOVE outdoor unit only), at maximum permitted liquid line pressure drop
Suction Line size	Tube size, inches OD
Suction Line (PD) (F)	Suction line pressure drop, saturated temperature, degree F
(Cap Red)	Capacity reduction caused by suction line pressure drop GT 2 deg F
Charge	Charge Quantity, lbs. Calculated for both liquid line sizes (where applicable), but only with larger suction line size (where applicable)
#/TR	Charge to unit capacity ratio, lbs per ton (at 45 F SST, 95 F ODA)

# TYPICAL PIPING AND WIRING

## Roof Installation and a Ceiling-Mounted Fan Coil

### HORIZONTAL INSTALLATION

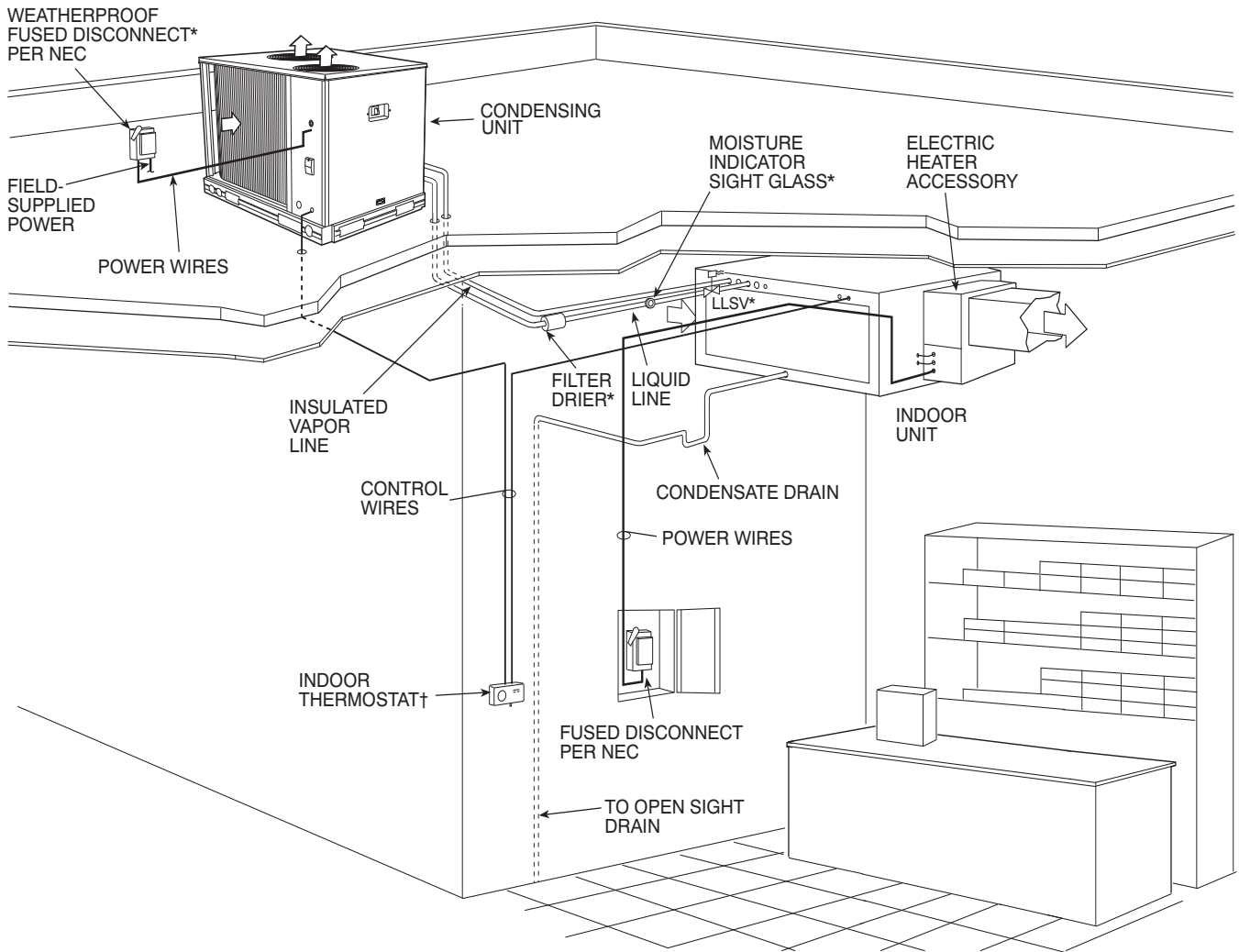

C150197

#### LEGEND:

NEC - National Electrical Code

TXV - Thermostatic Expansion Valve

\* Field-supplied

† Double riser may be required. Consult condensing unit product data catalog for details.

#### NOTES:

1. All piping must follow standard refrigerant piping techniques. Refer to ICP System Design Manual for details.
2. All wiring must comply with the applicable local and national codes.
3. Wiring and piping shown are general points-of-connection guides only and are not intended for, or to include all details for, a specific installation.
4. Liquid line solenoid valve (solenoid drop control) is recommended to prevent refrigerant migration to the compressor on line links above 75 feet.
5. Internal factory-supplied TXVs not shown.

# TYPICAL PIPING AND WIRING (CONT.)

## Roof Installation and a Vertical Discharge Fan Coil

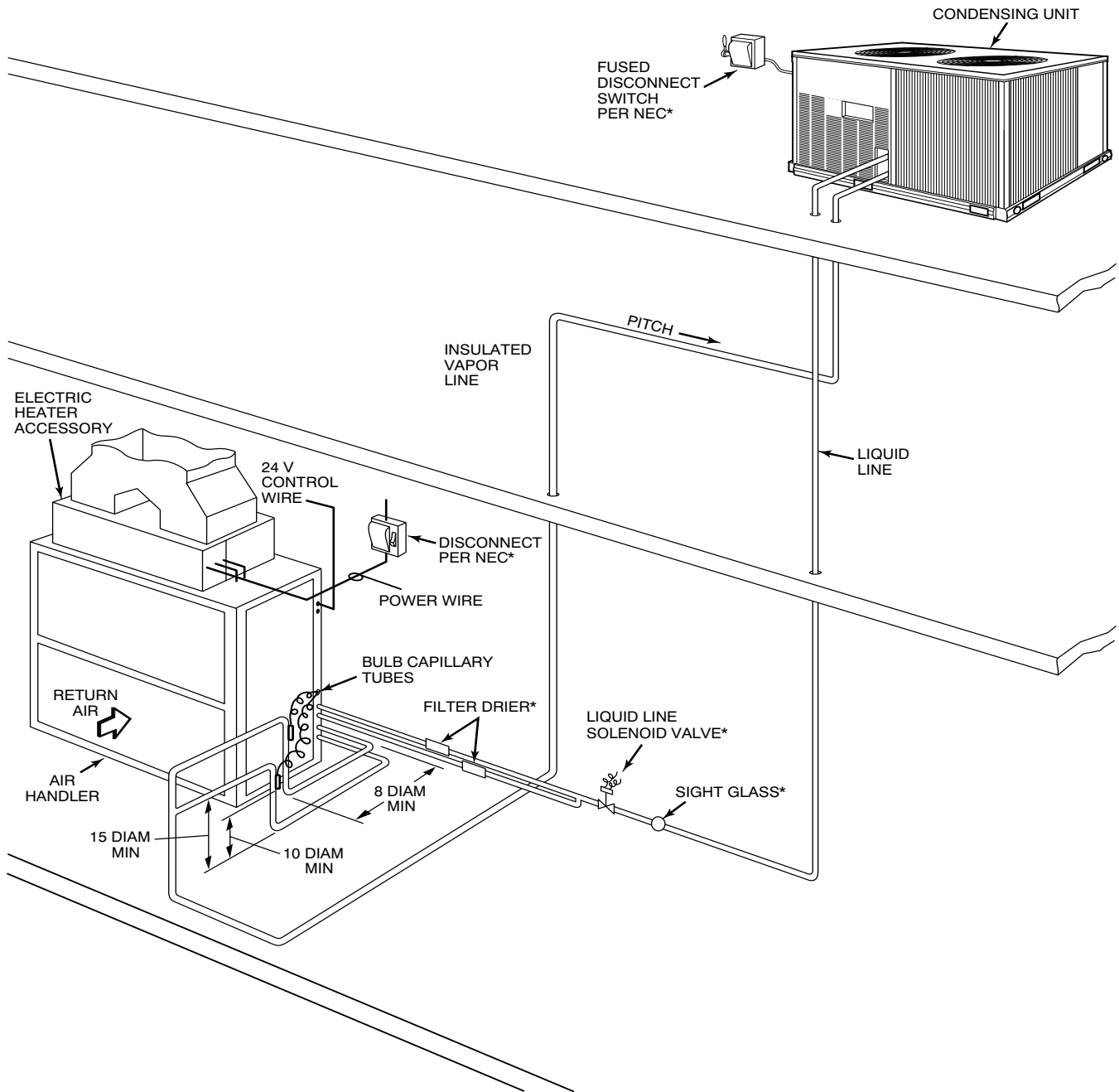

### LEGEND

- DIAM** — Diameter
- NEC** — National Electrical Code
- TXV** — Thermostatic Expansion Valve
-  Piping

\*Field supplied

### NOTES:

1. All piping must follow standard refrigerant piping techniques. Refer to System Design Manual for details.
2. All wiring must comply with applicable local and national codes.
3. Wiring and piping shown are general points-of-connection guides only and are not intended for, or to include all details for, a specific installation.
4. Liquid line solenoid valve (solenoid drop control) is recommended to prevent refrigerant migration to the compressor on line links above 75 feet.
5. Internal factory-supplied TXVs and check valves not shown.

C150435



# TYPICAL PIPING AND WIRING (CONT.)

## Ground Level Installation and Vertical Discharge Fan Coil

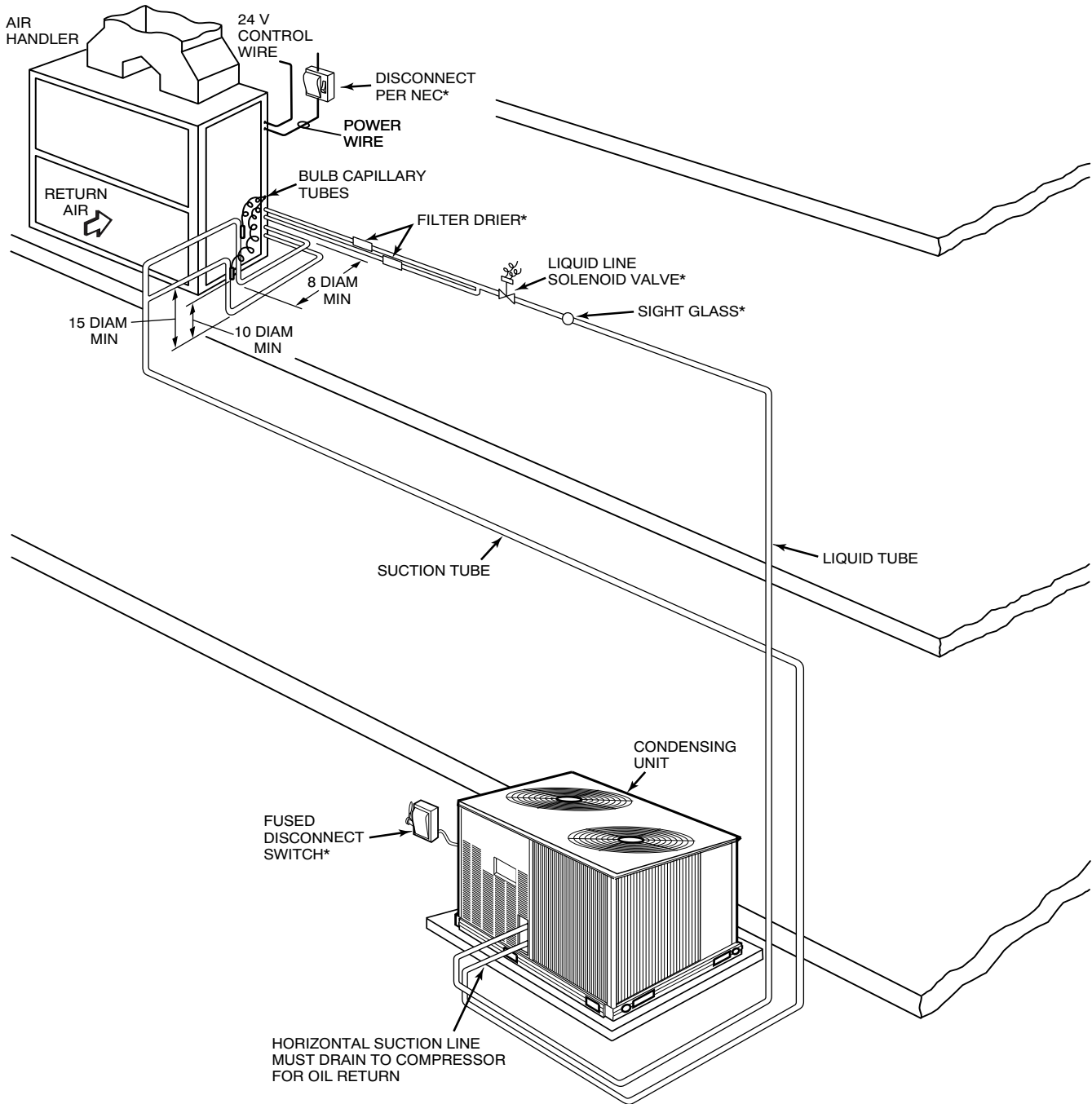

### LEGEND

- DIAM** — Diameter
- NEC** — National Electrical Code
- TXV** — Thermostatic Expansion Valve
-  Piping

\*Field supplied

### NOTES:

1. All piping must follow standard refrigerant piping techniques. Refer to System Design Manual for details.
2. All wiring must comply with applicable local and national codes.
3. Wiring and piping shown are general points-of-connection guides only and are not intended for, or to include all details for, a specific installation.
4. Liquid line solenoid valve (solenoid drop control) is recommended to prevent refrigerant migration to the compressor on line links above 75 feet.
5. Internal factory-supplied TXVs and check valves not shown.

C150433

# TYPICAL PIPING AND WIRING (CONT.)

## Dual Condensing Units and a Dual Circuit Fan Coil

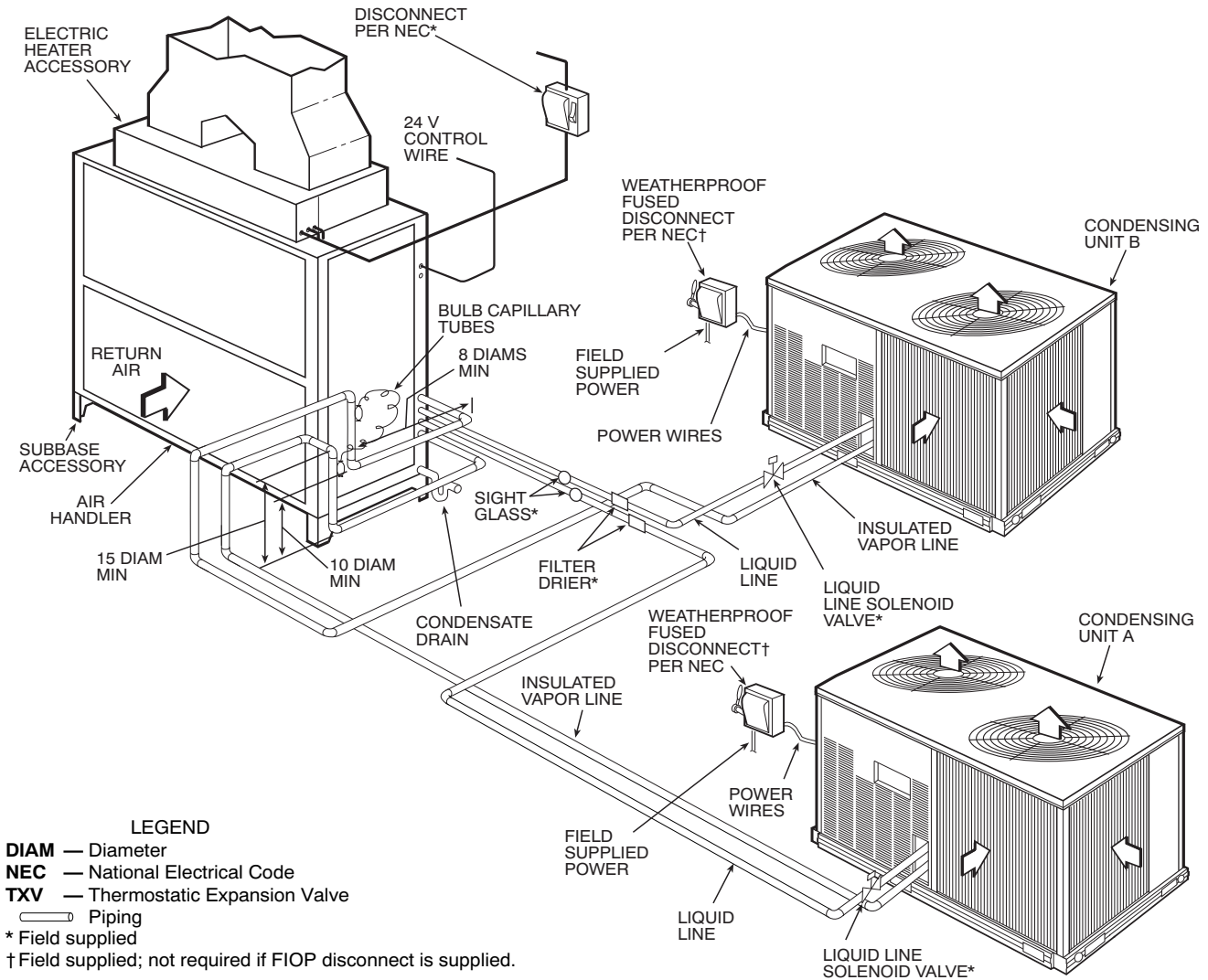

C150437

# GUIDE SPECIFICATIONS

## Commercial Air-Cooled Condensing Units

### HVAC Guide Specifications

Size Range: **6 to 20 Tons, Nominal**

ICP Model Numbers: **CAS, Single Circuit (072 - 241 Models) CAS, Dual Circuit (120 – 240 Models)**

#### Part 1 — General

##### 1.01 SYSTEM DESCRIPTION

Outdoor-mounted, air-cooled condensing unit suitable for on-the-ground or rooftop installation. Unit shall consist of a hermetic scroll air-conditioning compressor(s) assembly, an air-cooled coil, propeller-type condenser fans, and a control box. Unit shall discharge supply air upward as shown on contract drawings. Unit shall be used in a refrigeration circuit matched with a packaged air-handling unit.

##### 1.02 QUALITY ASSURANCE

- A. Unit shall be rated in accordance with AHRI Standard 360.
- B. Unit construction shall comply with ANSI/ASHRAE 15 safety code latest revision and comply with NEC.
- C. Unit shall be constructed in accordance with UL 1995 standard and shall carry the UL and UL, Canada label.
- D. Unit cabinet shall be capable of withstanding 500-hour salt spray exposure per ASTM B117 (scribed specimen).
- E. Air-cooled condenser coils for hermetic scroll compressor units CAS shall be leak tested at 150 psig, and pressure tested at 650 psig.
- F. Unit shall be manufactured in a facility registered to ISO 9001:2000 manufacturing quality standard.

##### 1.03 DELIVERY, STORAGE, AND HANDLING

Unit shall be shipped as single package only, and shall be stored and handled according to unit manufacturer's recommendations.

##### 1.04 WARRANTY (FOR INCLUSION BY SPECIFYING ENGINEER.)

#### Part 2 — Products

##### 2.01 EQUIPMENT

###### A. General:

Factory-assembled, single piece, air-cooled condensing unit. Contained within the unit enclosure shall be all factory wiring, piping, controls, compressor, holding charge, and special features required prior to field start-up.

###### B. Unit Cabinet:

1. Unit cabinet shall be constructed of galvanized steel, bonderized and coated with a prepainted baked enamel finish.
2. A heavy-gauge roll-formed perimeter base rail with forklift slots and lifting holes shall be provided to facilitate rigging.

###### C. Condenser Fans:

1. Condenser fans shall be direct driven, propeller type, discharging air vertically upward.
2. Fan blades shall be balanced.
3. Condenser fan discharge openings shall be equipped with PVC-coated steel wire safety guards.
4. Condenser fan and motor shaft shall be corrosion resistant.

###### D. Compressor:

1. Compressor shall be of the hermetic scroll type .
2. Compressor shall be mounted on rubber grommets.
3. Compressors shall include overload protection.
4. Compressors shall be equipped with a crankcase heater.
5. Compressor shall be equipped with internal high pressure and high temperature protection.
6. CAS180 and 240 sizes shall use two scroll compressors manifold together. CAS091(D) and CAS091(E) shall use one refrigerant circuit with one 2-stage compressor.

###### E. Condenser Coils:

###### 1. Standard Aluminum fin – Copper Tube Coils:

- a. Standard evaporator and condenser coils shall have aluminum lanced plate fins mechanically bonded to seamless internally grooved copper tubes with all joints brazed.

- b. Evaporator coils shall be leak tested to 150 psig, pressure tested to 450 psig, and qualified to UL 1995 burst test at 1775 psig.
  - c. Condenser coils shall be leak tested to 150 psig, pressure tested to 650 psig, and qualified to UL 1995 burst test at 1980 psig.
2. Optional Pre-coated aluminum-fin condenser coils:
    - a. Shall have a durable epoxy-phenolic coating to provide protection in mildly corrosive coastal environments.
    - b. Coating shall be applied to the aluminum fin stock prior to the fin stamping process to create an inert barrier between the aluminum fin and copper tube.
    - c. Epoxy-phenolic barrier shall minimize galvanic action between dissimilar metals.
  3. Optional Copper-fin evaporator and condenser coils:
    - a. Shall be constructed of copper fins mechanically bonded to copper tubes and copper tube sheets.
    - b. Galvanized steel tube sheets shall not be acceptable.
    - c. A polymer strip shall prevent coil assembly from contacting the sheet metal coil pan to minimize potential for galvanic corrosion between coil and pan.
  4. Optional E-coated aluminum-fin evaporator and condenser coils:
    - a. Shall have a flexible epoxy polymer coating uniformly applied to all coil surface areas without material bridging between fins.
    - b. Coating process shall ensure complete coil encapsulation of tubes, fins and headers.
    - c. Color shall be high gloss black with gloss per ASTM D523-89.
    - d. Uniform dry film thickness from 0.8 to 1.2 mil on all surface areas including fin edges.
    - e. Superior hardness characteristics of 2H per ASTM D3363-92A and cross-hatch adhesion of 4B-5B per ASTM D3359-93.
    - f. Impact resistance shall be up to 160 in.-lb (ASTM D2794-93).
    - g. Humidity and water immersion resistance shall be up to minimum 1000 and 250 hours respectively (ASTM D2247-92 and ASTM D870-92).
    - h. Corrosion durability shall be confirmed through testing to be no less than 1000 hours salt spray per ASTM B117-90.

F. Refrigeration Components:

Refrigeration circuit components shall include liquid line service valve, suction line service valve, a full charge of compressor oil, and a partial holding charge of refrigerant.

G. Controls and Safeties:

1. Minimum control functions shall include:

- a. Control wire terminal blocks.
- b. Compressor lockout on auto-reset safety until reset from thermostat.
- c. Except for CAS091(G,H) models, each unit shall utilize the Comfort Alert™ Diagnostic Board that provides:
  - (1.) System Pressure Trip fault code indication
  - (2.) Short Cycling fault code indication
  - (3.) Locked Rotor fault code indication
  - (4.) Open Circuit fault code indication
  - (5.) Reverse Phase 3 fault code indication
  - (6.) Welded Contactor fault code indication
  - (7.) Low Voltage fault code indication
  - (8.) Anti-short cycle protection
  - (9.) Phase reversal protection

2. On CAS091 (G,H) models, the two stage digital scroll compressor is controlled by a discharge solenoid and non-adjustable digital timer to control the stages of compression. At part load the solenoid is closed and opens at intervals which equal desired stage of compression.

3. Minimum safety devices which are equipped with automatic reset (after resetting first at thermostat), shall include:

- a. High discharge pressure cutout.
- b. Low pressure cutout.

H. Operating Characteristics:

1. The capacity of the condensing unit shall meet or exceed \_\_\_\_\_ Btuh at a suction temperature of \_\_\_\_\_°F. The power consumption at full load shall not exceed \_\_\_\_\_ kW.
2. The combination of the condensing unit and the evaporator or fan coil unit shall have a total net cooling capacity of \_\_\_\_\_ Btuh or greater at conditions of \_\_\_\_\_ cfm entering-air temperature at the evaporator at \_\_\_\_\_°F wet bulb and \_\_\_\_\_°F dry bulb, and air entering the condensing unit at \_\_\_\_\_°F.
3. The system shall have an EER of \_\_\_\_\_ Btuh/Watt or greater at standard AHRI conditions.
4. Standard unit shall be capable to operate up to 125°F (52°C) and down to 40°F (4°C)

I. Electrical Requirements:

1. Nominal unit electrical characteristics shall be \_\_\_\_\_ v, 3-ph, 60 Hz. The unit shall be capable of satisfactory operation within voltage limits of \_\_\_\_\_ v to \_\_\_\_\_ v.
2. Unit electrical power shall be single-point connection.
3. Unit control circuit shall contain a 24-v transformer for unit control.

J. Special Features:

1. Low-Ambient Temperature Control:

A low-ambient temperature control shall be available as a factory-installed option or as a field-installed accessory. This low-ambient control shall regulate speed of the condenser-fan motors in response to the saturated condensing temperature of the unit. The control shall maintain correct condensing pressure at outdoor temperatures down to -20°F (-29°C).

2. Unit-Mounted, Non-Fused Disconnect Switch:

Switch shall be factory-installed and internally mounted. NEC and UL-approved non-fused switch shall provide unit power shutoff. Switch shall be accessible from outside the unit and shall provide power off lockout capability. Non-fused disconnect switch cannot be used when unit MOCP electrical rating exceeds 80 amps.

3. Convenience Outlet:

Outlet shall be factory-installed and internally mounted with easily accessible 115-v female receptacle. Outlet shall include 15 amp GFI (ground fault interrupter) receptacle with independent fuse protection. Voltage required to operate convenience outlet shall be provided by a factory-installed step-down transformer. Outlet shall be accessible from outside the unit.

4. Louvered Hail Guard Package:

Louvered hail guard package shall protect coils against damage from hail and other flying debris.

