

OPERATOR'S MANUAL

VLP SERIES LEVER CHAIN HOISTS

3/4 TON THROUGH 3 TON



TABLE OF CONTENTS

Warranty policy	1
Information for your safety.....	1
Prior to installation	2
Safety precautions	2
Operation.....	3
Inspection and maintenance	4
Hooks	5
Chain	5
Disassembling and assembling	6
Parts breakdown	7
Parts list.....	8

ONE YEAR LIMITED WARRANTY

JET® Lever Chain Hoists are guaranteed to be free of defects in material and workmanship. If one of these products fails during the first year of operation due to defective material or workmanship it will be repaired or replaced at our discretion. Normal wear and tear on moving parts is excluded from this guarantee. This guarantee does not apply to any product showing signs of misuse, overloading, alteration, or improper maintenance.

WARRANTY PROCEDURE

After receiving authorization from one of the offices listed below, any product for which there is a warranty claim must be returned prepaid to an authorized JET® warranty depot along with proof of purchase.

Addresses for information on JET® Material Handling products, warranty depots or distributors:

Vancouver	Edmonton	Winnipeg	Toronto	Montreal	Halifax
Tel: (604) 523-8665	Tel: 1-800-472-7685	Tel: (204) 632-6970	Tel: (905) 565-8661	Tel: (514) 332-4618	Tel: (902) 468-8324
Toll Free: 1-800-472-7685	Fax: 1-800-663-7742	Fax: (204) 694-9534	Fax: (905) 565-7266	Fax: (514) 332-4777	Fax: (902) 468-3461
Fax: (604) 526-5381					
Toll Free: 1-800-663-7742					

INFORMATION FOR YOUR SAFETY

It is the responsibility of the owner/user to install, inspect, test, maintain, and operate these lever hoists in accordance with ASME B30.21, Safety Standard for Manually Operated Lever Hoists.

These general instructions deal with the normal installation, operation and maintenance situations encountered with the lever hoists described herein. The instructions should not be interpreted to anticipate every possible contingency or to anticipate the final system or configuration that uses these lever hoists.

These instructions include information for a variety of lever hoists. Therefore, all instructions and information may not apply to one specific lever hoist. Disregard those portions of the instructions that do not apply.

If the lever hoist owner/user requires additional information, or if any information in these instructions are not clear, contact your local JET® Material Handling Products distributor.

This lever hoist should not be installed, operated, or maintained by any person who has not read all the contents of these instructions, and ASME B30.21, Safety Standard for Manually Operated Lever Hoists. Failure to read and comply with these instructions or any of the warnings or limitations noted herein can result in serious bodily injury or death, and/or property damage.

Only trained and qualified personnel shall operate and maintain this equipment.

Equipment described herein is not designed for, and should not be used for lifting, supporting, or transporting people.

User should not use this lever hoist in conjunction with other equipment unless necessary and/or required safety devices applicable to the system are installed by the user.

Modifications to upgrade, rerate or otherwise alter these lever hoists shall be authorized only by the original equipment manufacturer or qualified professional engineer.

PRIOR TO INSTALLATION

Check for damage during shipment. Place claim with carrier if any damage is discovered. DO NOT install or use a damaged lever hoist.

Check and verify that structure or other equipment that will support the lever hoist has a rated load capacity equal to or greater than the rated load capacity of the lever hoist to be used.

OPERATION

Before initial operation of hoist:

1. Read and comply with all instructions and warnings furnished with or attached to lever hoist.
2. Check lubricant.
3. Check operation of brake.
4. Check that chain is properly seated in sheaves and that chain is not twisted, kinked, or damaged.

Before each shift:

1. Inspect hooks for nicks, gouges, cracks, and signs of pulling apart or twisting.
2. Inspect hook latch for proper operation.
3. Check chain for kinks or twists.
4. Check operation of brake.
5. Replace warning label if missing or illegible.

Before operating:

1. Be certain all personnel are clear of the load to be lifted and moved.
2. Make sure load will clear stock piles, machinery, or other obstructions when hoisting and travelling the load.
3. Eliminate any twists or kinks in the load chain.

SAFETY PRECAUTIONS

- A. **READ** these instructions and ASME B30.21, Safety Standard for Manually Operated Lever Hoists before installing, operating, or maintaining this equipment.
- B. **WARN** personnel of approaching loads.
- C. **DO NOT**
 1. Lift more than rated load.
 2. Operate lever hoist when it is restricted from forming a straight line with the direction of loading.
 3. Operate with twisted, kinked, or damaged chain.
 4. Operate if chain is not seated in sheaves or sprockets.
 5. Wrap chain around load or use chain as a sling.
 6. Operate unless load is properly applied to the saddle or bowl of the hook.
 7. Operate if load is applied to the tip of the hook.
 8. Operate with damaged or missing hook latches.
 9. Lift people or lift loads over people.
 10. Operate with side-pulling or side-loading of load to lever hoist.
 11. Operate a damaged or malfunctioning lever hoist.
 12. Operate with other than hand power.
 13. Remove, deface, or obscure warning label or labels on lever hoist.
 14. Leave load suspended when lever hoist is unattended unless specific precautions have been instituted and are in place.
 15. Lengthen load chain or repair damaged load chain by welding.
 16. Use chain as a ground for welding.
 17. Hammer on lever.
 18. Use extensions on lever.
 19. Lift one load with more than one lever hoist, unless each lever hoist is rated to support the entire load in the event one or more lever hoists is disabled, shifting load to the other lever hoists.

OPERATION

TO RAISE LOAD:

1. Set change lever on handle to "UP" position.
2. Operate handle to move load.

TO LOWER LOAD:

1. Set change lever on handle to "DOWN" position.
2. Operate handle to move load.

TO ADJUST CHAIN LENGTH:

TO SHORTEN:

Set change lever to "NEUTRAL" and turn feed hand wheel clockwise or pull free end of chain.

TO LENGTHEN:

Set change lever to "NEUTRAL" and turn feed hand wheel counter-clockwise or pull hook end of chain.

BRAKE LOCK:

If the lever hoist is unloaded by means other than operating the lever, or if the bottom hook is pulled tight against the hoist body, brake lock can occur. To unlock brake, move selector to DOWN position and pull sharply on lever.

SHOCK LOADS:

Do not allow a load to drop, such as over the edge of a platform, while connected to a lever hoist. The sudden drop, even of an insignificant distance, can cause a severe momentary overload, seriously damaging the lever hoist and possibly resulting in the loss of the load. This can occur at loads well under the rated capacity.

REPLACEMENT OF CHAIN:

USE ONLY GENUINE JET GRADE 80 REPLACEMENT LOAD CHAIN

INSPECTION AND MAINTENANCE

Prior to initial use, all new, modified, and repaired hoists shall be inspected in accordance with Table 2. Thereafter, inspections shall be conducted at intervals shown in Table 1; and items to be inspected are indicated in Table 2 by F (Frequent) or P (Periodic).

Frequent Inspections - Visual inspection by the operator or other authorized person. This inspection includes listening for unusual sounds while the hoist is operated that may indicate deficiencies.

Periodic Inspections - Audible-visual inspection as for Frequent Inspections, with some disassembly to allow a more detailed inspection if external conditions indicate the need.

Exception: Brakes require more than audible-visual inspection. Check daily by operating lever hoist with and without load, stopping at various positions to test holding power and amount of drift, if any occurs.

TO ADJUST BRAKE:

1. Remove cotter pin from castle nut on feed knob.
2. Screw castle nut on snugly, then back nut off just enough to line up holes for cotter pin. Replace cotter pin.

TABLE 1 - FREQUENCY OF INSPECTION

SERVICE	FREQUENT (F) INSPECTION	PERIODIC (P) INSPECTION
Normal	Monthly	Annually
Heavy	Weekly to Monthly	Semi-Annually
Severe	Daily to Weekly	Quarterly

TABLE 2 - INSPECTION CHART

In chart, F indicates Frequent Inspection, P indicates Periodic Inspection

LOCATION	CHECK FOR	F	P	LOCATION	CHECK FOR	F	P
Braking mechanism	Slipping under load	✘		Hook Retaining Members (Pins, Bolts, Nuts)	Not tight or secure		✘
	Hard to release	✘			Hook Latch	Damaged; does not close	✘
Brake Parts	Glazing		✘	Suspension Members (Sheaves, hand-wheels, chain attachments, suspension bolts or pins)		Excessive wear	
		Oil contamination			✘	Cracks	✘
Pawl; Ratchet	Excessive wear		✘	Gears	Distortion		✘
Pawl Spring	Corrosion; stretch		✘		Broken or worn teeth		✘
Hooks	Chemical damage	✘			Cracks		✘
	Deformation	✘		Inadequate lubrication		✘	
	5% in excess of normal throat opening		✘	Load Block; Suspension Housing	Distortion	✘	✘
	10° twist from plane of unbent hook		✘		Cracks	✘	✘
	Cracks (dye penetrant, magnetic particle, or other suitable detection method)		✘	Trolley; Supporting Structure	Possible inability to continue supporting imposed loads		✘
			Bolts, Nuts, Rivets	Not tight or secure		✘	
			WARNING Label	Removed or illegible	✘		

Refer to ASME B30.21 for additional information on inspection, test, and maintenance.

HOOKS

WARNING

1. Any hook that requires replacement because of excessive bends, twists, or throat opening indicates abuse or overloading of the hoist. Therefore, other load-supporting components of the lever hoist should be inspected for possible damage when such conditions are found.
2. Never repair hooks by welding or reshaping. Heat applied to the hook will alter the original heat treatment of the hook material and reduce the strength of the hook.
3. Never weld handles or other attachments to the hook. Heat applied to the hook will alter the original heat treatment of the hook material and reduce the strength of the hook.

HOOKS INSPECTION

Refers to ASME B30.10, Safety Standard for Hooks. Inspect hooks and measure hook throat opening at least once a month. Between regular inspections check visually daily for deformation, distortion, twisting, damage, and missing or damaged hook latches. Inspect as follows:

1. Measure hook opening at raised dots to check for stretch. Raised dots provide a constant reference point and eliminate measurement errors. Replace hook when measurement between dots reaches "Dimension Y Replace Hook" figures below.

CAPACITY TONS	DIMENSION Y NEW HOOK	DIMENSION Y REPLACE HOOK	DIMENSION H NEW HOOK	DIMENSION H REPLACE HOOK
3/4	37.5mm	39.8mm	19.5mm	18.5mm
1-1/2	47mm	50mm	25mm	24mm
3	62.5mm	66mm	35.5mm	34mm

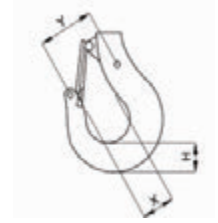

Figure 1

2. Measure hook depth at load bearing point in the bowl of the hook. Hook must be replaced when wear at load bearing point reaches "Dimension H Replace Hook" figures.
3. A bend or twist of the hook exceeding 10° from the plane of the unbent hook requires replacement of the hook.
4. A hook latch that is missing shall be replaced.
5. A hook latch that is inoperative shall be repaired or replaced.
6. A hook with a hook latch that does not close the throat opening of the hook shall be removed from service until the latch is replaced or repaired.
7. Hooks having damage from chemicals, corrosion, or deformation shall be repaired or replaced.

Due to variations in the manufacturing process, the dimensions of a new hook are variable. For accurate record keeping, we recommend users record measurements Y and H of the hook before use. Record this information in the spaces above and calculate the replacement value by multiplying by 1.05 for Dimension Y or by 0.95 for Dimension H.

CHAIN

Inspect chain at least once a month. Between regular inspections, check visually daily for nicks, gouges, weld splatter, corrosion, or distorted links. Inspect chain thoroughly if it does not feed smoothly over load sheaves. Inspect as follows:

1. Clean chain with solvent before inspection.
2. Test hoist with load and observe operation of chain over load sheaves.
3. Slacken chain and inspect contact points for excessive wear. Refer to Figure 2.
4. Using caliper-type gauge, measure inside length of 5 links under light tension. Refer to Figure 3. Replace chain if measurement exceeds maximum allowable gauge length as follows:

CAPACITY TONS	CHAIN WIRE DIAMETER	5 LINKS NORMAL	5 LINKS MAXIMUM
3/4	6.0mm	90mm	92.7mm
1-1/2	8.0mm	120mm	123.6mm
3 + 6	100mm	150mm	154.5mm

Figure 2

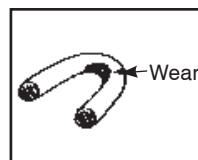
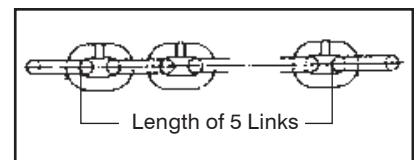

Figure 3



DISASSEMBLING AND ASSEMBLING

You will occasionally want to disassemble your lever hoist for cleaning. To do so, proceed as follows:

To disassemble gear case:

1. Lay tool on side, gear case facing up.
2. Disconnect four hexnuts on gear casing.
3. Lift off gear casing.
4. Remove dirt from surfaces, using solvent or rag.

To assemble gear case:

1. Place gear case back on bolts, matching gear shafts to bushings on interior of gear casing.
2. Secure firmly with four hexnuts.

To disassemble brake and lever for cleaning:

1. Place tool on side, feed handwheel facing up.
2. Remove cotter pin from castle nut in handwheel.
3. Remove castle nut and washer.
4. Remove three Phillips screws and washers from handwheel.
5. Lift off feed handwheel.
6. Remove four hexnuts on side of brake cover.
7. Unscrew lever. It may be necessary to hold pinion shaft stationary.
8. Lift off brake cover and lever as a unit. Brake is now visible.
9. Remove brake and linings, keeping track of sequence of removal.
10. Remove dirt from surfaces, using solvent or rag. If brake linings show wear or cracks, replace.

To disassemble lever for cleaning:

1. Remove lever from hoist (after removing feed handwheel as described in steps 1 through 5 above).
2. Remove two hexnuts from back of lever and two bolts from front of lever.
3. Flip lever upside down, dropping back insert into hand.
4. Clean with solvent and relubricate.

To assemble lever:

1. Place insert into back of lever.
2. Fasten nuts and bolts. It may be necessary to jog the direction lever a few times to allow the parts to mate correctly.

To assemble brake:

1. Set brake and linings back into place.
2. Replace spring with wide end toward lever.
3. Place brake cover and lever back on bolts, then turn lever clockwise to screw it down, securing with hexnuts.
4. Replace feed handwheel and screws.
5. To set brake:
 - Place feed knob back on.
 - Screw castle nut on snugly, then reverse only far enough to line up holes for cotter pin.
 - Insert cotter pin and secure with proper tool.

VLP LEVER HOIST PRODUCT # 110302, 110303, 110304

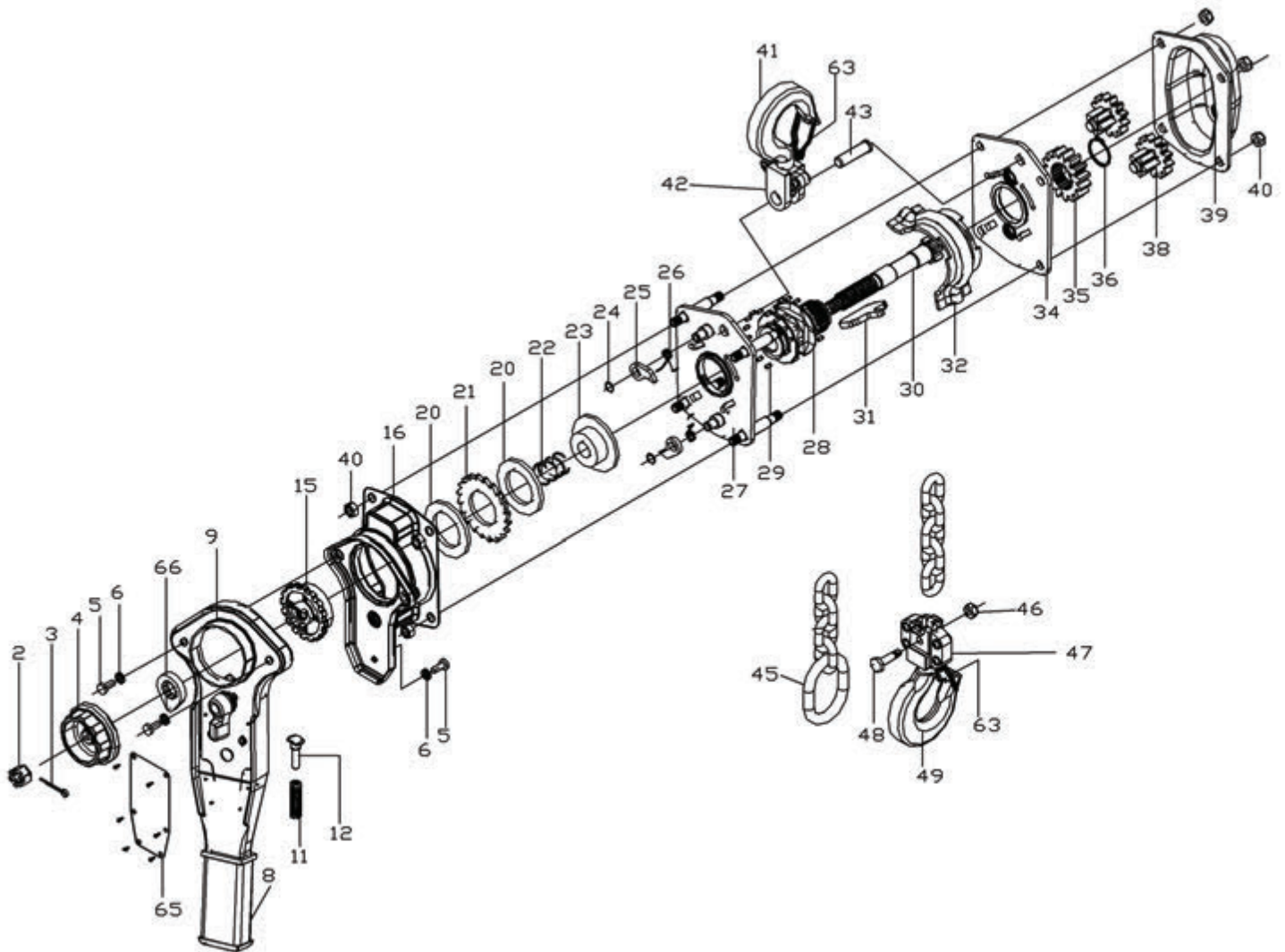

VLP LEVER HOIST PRODUCT # 110302, 110303, 110304

REF	PART NUMBER	PART NUMBER	PART NUMBER	DESCRIPTION	REQ
2	PVI-VLP75-2	PVI-VLP150-2	PVI-VLP300-2	CASTLE NUT	1
3	PVI-VLP75-3	PVI-VLP150-3	PVI-VLP300-3	SPLIT PIN	1
4	PVI-VLP75-4	PVI-VLP150-4	PVI-VLP300-4	HAND WHEEL	1
5	PVI-VLP75-5	PVI-VLP150-5	PVI-VLP300-5	HEX HEAD SCREW	3
6	PVI-VLP75-6	PVI-VLP150-6	PVI-VLP300-6	SPRING WASHER	3
8	PVI-VLP75-8	PVI-VLP150-8	PVI-VLP300-8	RUBBER GRIP	1
9	PVI-VLP75-9	PVI-VLP150-9	PVI-VLP300-9	LEVER HANDLE ASS, 8, 9, 11 ,12	1
11	PVI-VLP75-11	PVI-VLP150-11	PVI-VLP300-11	CHANGE OVER SPRING	1
12	PVI-VLP75-12	PVI-VLP150-12	PVI-VLP300-12	SPRING SHAFT	1
15	PVI-VLP75-15	PVI-VLP150-15	PVI-VLP300-15	CHANGE OVER GEAR	1
16	PVI-VLP75-16	PVI-VLP150-16	PVI-VLP300-16	BRAKE COVER ASSEMBLY	1
20	PVI-VLP75-20	PVI-VLP150-20	PVI-VLP300-20	FRICTION DISC PAIR	1
21	PVI-VLP75-21	PVI-VLP150-21	PVI-VLP300-21	RATCHET DISC	1
22	PVI-VLP75-22	PVI-VLP150-22	PVI-VLP300-22	TWISTING SPRING	1
23	PVI-VLP75-23	PVI-VLP150-23	PVI-VLP300-23	BRAKE SEAT	1
24	PVI-VLP75-24	PVI-VLP150-24	PVI-VLP300-24	SNAP RING	2
25	PVI-VLP75-25	PVI-VLP150-25	PVI-VLP300-25	PAWL	2
26	PVI-VLP75-26	PVI-VLP150-26	PVI-VLP300-26	PAWL SPRING	2
27	PVI-VLP75-27	PVI-VLP150-27	PVI-VLP300-27	LEVER SIDE PLATE ASS	1
28	PVI-VLP75-28	PVI-VLP150-28	PVI-VLP300-28	LOAD SPROCKET	1
29	PVI-VLP75-29	PVI-VLP150-29	PVI-VLP300-29	ROLLER SET RIGH AND LEFT	1
30	PVI-VLP75-30	PVI-VLP150-30	PVI-VLP300-30	DRIVING PINION	1
31	PVI-VLP75-31	PVI-VLP150-31	PVI-VLP300-31	STRIPPER	1
32	PVI-VLP75-32	PVI-VLP150-32	PVI-VLP300-32	CHAIN GUIDE PLATE	1
34	PVI-VLP75-34	PVI-VLP150-34	PVI-VLP300-34	GEAR SIDE PLATE ASS	1
35	PVI-VLP75-35	PVI-VLP150-35	PVI-VLP300-35	LOAD GEAR	1
36	PVI-VLP75-36	PVI-VLP150-36	PVI-VLP300-36	SNAP RING	1
38	PVI-VLP75-38	PVI-VLP150-38	PVI-VLP300-38	SPUR GEAR ASSEMBLY	1
39	PVI-VLP75-39	PVI-VLP150-39	PVI-VLP300-39	GEAR COVER ASSEMBLY	1
40	PVI-VLP75-40	PVI-VLP150-40	PVI-VLP300-40	LOCK NUT	8
43	PVI-VLP75-43	PVI-VLP150-43	PVI-VLP300-43	TOP HOOK SHAFT	1
45	PVI-VLP75-45	PVI-VLP150-45	PVI-VLP300-45	END RING	1
46	PVI-VLP75-46	PVI-VLP150-46	PVI-VLP300-46	CHAIN PIN NUT	1
48	PVI-VLP75-48	PVI-VLP150-48	PVI-VLP300-48	CHAIN PIN	1
63	PVI-VLP75-63	PVI-VLP150-63	PVI-VLP300-63	SAFETY LATCH KIT	2
65	PVI-VLP75-65	PVI-VLP150-65	PVI-VLP300-65	NAME PLATE WRIVETS	1
66	PVI-VLP75-66	PVI-VLP150-66	PVI-VLP300-66	STOP KNOB	1
41	PVI-VLP75-41	PVI-VLP150-41	PVI-VLP300-41	TOP HOOK ASSEMBLY, 42, 43, 63	1
49	PVI-VLP75-49	PVI-VLP150-49	PVI-VLP300-49	BOTTOM HOOK 46, 47, 48, 63	1