

**FMA5L, FMA5X**  
**Multifamily Wall-Hung Fan Coils**  
**Sizes 18 To 36 — 1-1/2 To 3 Nominal Tons**  
**for Puron Advance™ (R-454B) Refrigerant**



**Product Data**

**All Models**

- 1-1/2, 2, 2-1/2, and 3 Tons
- Upflow application only
- Accessory field-installed electric heat kits available in 5, 7.5, or 10 kW
- 208/230-1-60 supply voltage
- Cabinet exterior is galvanized sheet metal
- Cabinet air leakage rate below 1.4% when tested to ASHRAE Standard 193
- Insulated for conditioned space (not to be installed in unconditioned spaces)
- All Aluminum coils
- Puron Advance refrigerant, TXV standard

**Performance**

- PSC motor on all FMA5L
- ECM motor on all FMA5X
- Motor suspended on rubber grommets for quieter operation
- Fresh air intake knockouts in cabinet

**Easy To Install And Service**

- Units fits between standard stud spacings
- All service access is located in the front
- Primary and secondary drain connections exit from the bottom, access panel in bottom of cabinet
- No return-air ductwork required in specific applications
- Wall hanging brackets included with the unit



A180014

**Puron**  
**ADVANCE™**



Use of the AHRI Certified TM Mark indicates a manufacturer's participation in the program. For verification of certification for individual products, go to [www.ahridirectory.org](http://www.ahridirectory.org).

A240003

**WARRANTY**

- Default 5-year parts limited warranty:
  - 10-year parts limited warranty with timely registration\*.
 Equipment must be registered within 90 days of original installation, except in jurisdictions where warranty benefits cannot be conditioned on registration.
- \* Applies to original purchaser/homeowner and not available to subsequent owners, except in jurisdictions where laws dictate otherwise.

See Warranty certificate for complete details and restrictions.

Model	Tons	Nominal BTU	CFM (L/s)		Dimensions H x W x D in. (mm)	Filter Size in. (mm)	Ship Wt. lbs. (kg)
			Min	Max			
FMA5L1800AL	1-1/2	18,000	450 (212)	675 (319)	36-1/2 x 20-1/2 x 15 (928 x 521 x 381)	16 x 20 (406 x 508)	88 (40)
FMA5L2400AL	2	24,000	600 (283)	900 (425)			88 (40)
FMA5L3000AL	2-1/2	30,000	750 (354)	1125 (531)	39-1/2 x 22 x 19 (1004 x 559 x 483)	20 x 20 (508 x 508)	106 (48)
FMA5L3600AL	3	36,000	900 (425)	1350 (637)			106 (48)
FMA5X1800AL	1-1/2	18,000	450 (212)	675 (319)	36-1/2 x 20-1/2 x 15 (928 x 521 x 381)	16 x 20 (406 x 508)	84 (38)
FMA5X2400AL	2	24,000	600 (283)	900 (425)			84 (38)
FMA5X3000AL	2-1/2	30,000	750 (354)	1125 (531)	39-1/2 x 22 x 19 (1004 x 559 x 483)	20 x 20 (508 x 508)	99 (45)
FMA5X3600AL	3	36,000	900 (425)	1350 (637)			99 (45)

**Table 1 – Fan Coil Number Identification Guide**

	<b>F</b>	<b>M</b>	<b>A</b>	<b>5</b>	<b>X</b>	<b>2400</b>	<b>A</b>	<b>L</b>
F = Fan Coil								
M = Multi-Family		<b>TYPE</b>						
A = Apartment		<b>INSTALLATION TYPE</b>						
5 = Puron Advance				<b>REFRIGERANT</b>				
L = TXV & PSC Motor								
X = TXV & ECM Motor				<b>METERING DEVICE / BLOWER TYPE</b>				
1800 = 18,000 BTUH = 1-1/2 tons								
2400 = 24,000 BTUH = 2 tons								
3000 = 30,000 BTUH = 2-1/2 tons								
3600 = 36,000 BTUH = 3 tons						<b>NOMINAL CAPACITY</b>		
A = Marketing Revision								<b>REVISION</b>
L = Aluminum Coil								<b>SALES CODE / FEATURES</b>

**Table 2 – Electric Heater Model Number Identification Guide**

	<b>EHK</b>	<b>2</b>	<b>05</b>	<b>B</b>
EHK = Electric Heater Kit				
Sales Code				
05 = 5 kW				
08 = 7.5 kW				
10 = 10 kW				<b>NOMINAL HEAT VALUE</b>
Engineering Code				

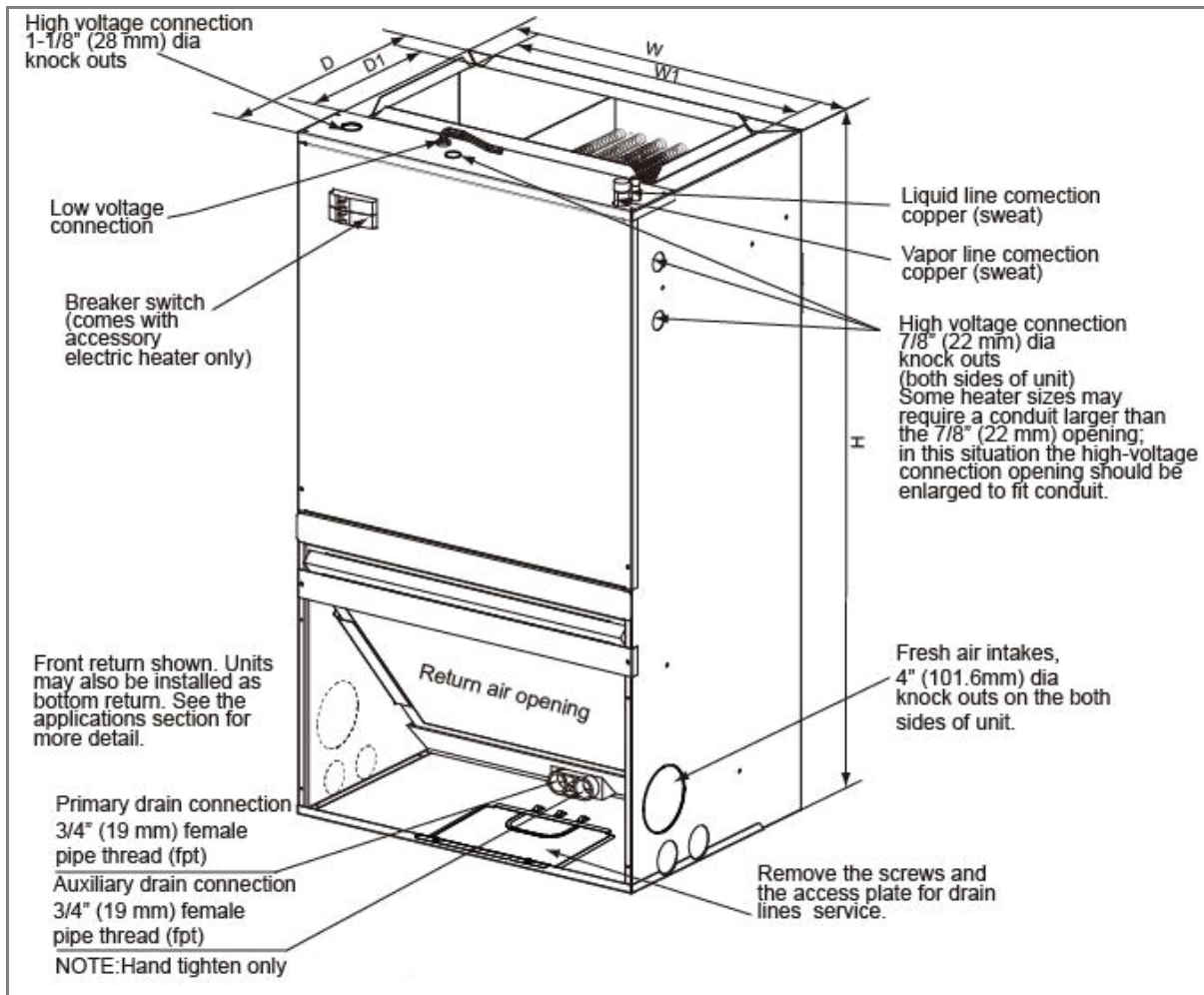

A170309

**Dimensional Data**

**Table 3 – Dimensions**

Unit Size		kbtu	18	24	30	36
Power supply		V-Ph-Hz	208/230V 1Ph 60Hz		208/230V 1Ph 60Hz	
Indoor unit	Dimension (WxHxD)	mm	521 x 928 x 381		559 x1004 x483	
		inch	20.5 x36.5 x15		22 x 39.5 x 19	
	Packing (WxHxD)	mm	580 x1060 x 440		615 x1140 x 540	
		inch	24.8 x 41.6 x 17.33		24.2 x 44.8 x 21.25	
Net/Gross Weight	Kg	40 (PSC) — 38 (ECM)	38 (PSC) — 43(ECM)	48 (PSC) — 45 (ECM)	45 (PSC) — 52(ECM)	
	lbs	88 (PSC) — 99 (ECM)	84 (PSC) — 95 (ECM)	106 (PSC) — 121(ECM)	99 (PSC) — 115(ECM)	
Duct Connection	Dimension (W1xD1)	mm	442 x 242		478 x 242	
		inch	17-2/5 x 9-1/2		18-4/5 x 9-1/2	
Drain Pan Connection	Primary/Auxiliary	inch	3/4 FPT / 3/4 FPT		3/4 FPT / 3/4 FPT	

**Table 4 – Required Clearances, All Models – inches (mm)**

No Heaters	All Sides	0
	From Supply Duct	0
With Heaters	All Sides	0
	From Supply Duct	0

Table 5 – Physical Data – FMA5L

Unit Size	18	24	30	36
Nominal Cooling Capacity (BTUH)	18,000	24,000	30,000	36,000
<b>COIL</b>				
Fins Per In.	17			
Face Area Ft <sup>2</sup>	2.2		3.0	
Coil Configuration	Slope			
<b>BLOWER &amp; MOTOR</b>				
Air Discharge	Upflow			
Blower Type	Direct Drive			
CFM (Nominal)	650	800	1130	1150
Motor Type	PSC	PSC	PSC	PSC
Motor HP	1/6	1/5	1/3	1/3
Rated RPM	1075			
Motor Speeds	3			
<b>FILTER</b>				
Field Installed - in (mm)	16 x 20 x 1 (406 x 508 x 25)		20 x 20 x 1 (508 x 508 x 25)	
<b>CONNECTIONS (Sweat)</b>				
Suction - in. (mm)	3/4 In. (19 mm)			
Liquid - in. (mm)	3/8 In. (9.5 mm)			
Condensate (FPT) - in. (mm)	3/4 In. (19 mm)			
<b>ELECTRICAL DATA</b>				
Voltage-Phase	208/230-1			
Hertz	60			
Circuit Amps	1.01	1.26	1.63	1.84
Minimum Circuit Ampacity	1	1.3	1.6	2.3
Maximum Circuit Protector	15 (A)			

Table 6 – Physical Data – FMA5X

Unit Size	18	24	30	36
Nominal Cooling Capacity (BTUH)	18,000	24,000	30,000	36,000
<b>COIL</b>				
Fins Per In.	17			
Face Area Ft <sup>2</sup>	2.2		3.0	
Coil Configuration	Slope			
<b>BLOWER &amp; MOTOR</b>				
Air Discharge	Upflow			
Blower Type	Direct Drive			
CFM (Nominal)	650	800	1100	1120
Motor Type	ECM			
Motor HP	1/3		1/2	
Rated RPM	1050			
Motor Speeds	5			
<b>FILTER</b>				
Field Installed - in (mm)	16 x 20 x 1 (406 x 508 x 25)		20 x 20 x 1 (508 x 508 x 25)	
<b>CONNECTIONS (Sweat)</b>				
Suction - in. (mm)	3/4 (19)			
Liquid - in. (mm)	3/8 (9.5)			
Condensate (FPT) - in. (mm)	3/4 (19)			
<b>ELECTRICAL DATA</b>				
Voltage-Phase	208/230-1			
Hertz	60			
Circuit Amps	1.01	1.64	2.16	2.26
Minimum Circuit Ampacity	2.4		3.4	
Maximum Circuit Protector, Amps	15			

Manufacturer reserves the right to change, at any time, specifications and designs without notice and without obligations.

## PERFORMANCE DATA

**Table 7 – PSC -Airflow Performance (Standard CFM)**

MODEL (SIZE, TON)	BLOWER SPEEDS	EXTERNAL STATIC PRESSURE (IN WC.)								
		0	0.1	0.2	0.3	0.4	0.5	0.6	0.7	0.8
18 (1-1/2)	Low	604	562	527	485	441	387	-	-	-
	Med	697	655	619	577	533	479	426	380	-
	High - Factory	802	761	721	682	637	592	541	481	408
24 (2)	Low	665	629	589	547	508	480	-	-	-
	Med	831	786	741	696	655	609	559	497	-
	High - Factory	932	881	833	786	742	689	636	574	515
30 (2-1/2)	Low	988	948	900	862	816	772	719	642	613
	Med - Factory	1197	1152	1097	1046	998	940	886	821	737
	High	1338	1284	1220	1159	1096	1029	960	879	792
36 (3)	Low	1118	1072	1018	971	920	876	819	759	693
	Med	1262	1213	1160	1098	1049	998	937	871	804
	High - Factory	1360	1311	1263	1229	1166	1074	1005	934	867

■ - NOTES: Shaded boxes represent airflow outside the required 300-450 CFM/ton.

- Airflow data includes electric heat and filter.
- Airflow data is with no return grill. When using a return grill on 18 & 24 sizes, decrease numbers above by approx. 10 CFM. For 30 & 36 sizes, decrease numbers above by approx. 50 CFM.

**Table 8 – ECM - Airflow Performance (Standard CFM)**

MODEL (SIZE, TON)	BLOWER SPEEDS	EXTERNAL STATIC PRESSURE (IN WC.)								
		0	0.1	0.2	0.3	0.4	0.5	0.6	0.7	0.8
18 (1-1/2)	Tap (1)	584	541	487	441	416	357	359	299	253
	Tap (2)	662	615	582	542	514	467	427	385	351
	Tap (3) - Factory	710	683	645	619	579	535	490	458	416
	Tap (4)	803	769	742	710	675	642	609	572	534
	Tap (5)	899	871	836	810	789	758	719	689	646
24 (2)	Tap (1)	584	541	487	441	416	357	359	299	253
	Tap (2)	662	615	582	542	514	467	427	385	351
	Tap (3)	710	683	645	619	579	535	490	458	416
	Tap (4)	803	769	742	710	675	642	609	572	534
	Tap (5) - Factory	899	871	836	810	789	758	719	689	646
30 (2-1/2)	Tap (1)	1063	1012	936	898	853	823	780	740	701
	Tap (2)	1133	1080	1026	991	958	904	858	813	769
	Tap (3) - Factory	1220	1194	1111	1100	1060	1007	952	910	855
	Tap (4)	1234	1200	1146	1229	1088	1046	1004	951	917
	Tap (5)	1341	1310	1247	1225	1192	1151	1101	1077	1033
36 (3)	Tap (1)	1063	1012	936	898	853	823	780	740	701
	Tap (2)	1133	1080	1026	991	958	904	858	813	769
	Tap (3)	1220	1194	1111	1100	1060	1007	952	910	855
	Tap (4) - Factory	1234	1200	1146	1229	1088	1046	1004	951	917
	Tap (5)	1341	1310	1247	1225	1192	1151	1101	1077	1033

■ - NOTES: Shaded boxes represent airflow outside the required 300-450 CFM/ton.

- Airflow based upon dry coil at 230V with no electric heat and factory-approved filter. For FMA5X airflow at 208V is approximately the same as 230V because the multi-tap ECM motor is a constant torque motor. The torque doesn't drop off at the speeds in which the motor operates.
- Airflow is equivalent for front or bottom return configurations.

**Table 9 – Minimum and Maximum CFM**

Unit Size	Min	Max
18	450	675
24	600	900
30	750	1125
36	900	1350

**Table 10 – Sensible Capacity (SHC) Correction Factor**

BYPASS FACTOR	ENTERING AIR DRY-BULB TEMPERATURE (°F)					
	79	78	77	76	75	Under 75
	81	82	83	84	85	Over 85
	ENTERING AIR DRY-BULB TEMPERATURE (°C)					
	26	25	25	24	24	Under 75
	27	28	28	29	29	Over 85
Correction Factor						
0.10	.098	1.96	2.94	3.92	4.91	Use formula shown below
0.20	0.87	1.74	2.62	3.49	4.36	
0.30	0.76	1.53	2.29	3.05	3.82	

Interpolation is permissible.

$$\text{Correction Factor} = 1.09 \times (1 - \text{BF}) \times (\text{db} - 80)$$

**NOTES:**

3. Contact manufacturer for cooling capacities at conditions other than shown in table.
4. Formulas:  
 Leaving db = entering db -  $\frac{\text{sensible heat cap.}}{1.09 \times \text{CFM}}$   
 Leaving wb = wb corresponding to enthalpy of air leaving coil ( $h_{lwb}$ )  
 $h_{lwb} = h_{ewb} - \frac{\text{total capacity (Btuh)}}{4.5 \times \text{CFM}}$   
 where  $h_{ewb}$  = enthalpy of air entering coil. Direct interpolation is permissible.  
 Do not extrapolate.
5. SHC is based on 80°F (27°C) db temperature of air entering coil.  
 Below 80°F (27°C) db, subtract (Correction Factor x CFM) from SHC.  
 Above 80°F (27°C) db, add (Correction Factor x CFM) to SHC.
6. Bypass Factor = 0 indicates no psychometric solution.  
 Use bypass factor of next lower EWB for approximation.

Table 11 – Gross Cooling Capacities (MBH)

INDOOR COIL AIR		SATURATED TEMPERATURE LEAVING EVAPORATOR (deg F)														
		35			40			45			50			55		
CFM	EWB	TC	SHC	BF	TC	SHC	BF	TC	SHC	BF	TC	SHC	BF	TC	SHC	BF
<b>UNIT SIZE 18</b>																
525	72	29.75	13.91	0.00	27.17	12.76	0.01	24.23	11.51	0.02	20.89	10.17	0.02	17.13	8.77	0.02
	67	24.71	14.48	0.03	22.05	13.24	0.03	19.02	11.91	0.03	15.59	10.50	0.03	11.73	9.03	0.03
	62	20.11	14.95	0.03	17.35	13.63	0.03	14.34	12.28	0.03	11.68	11.68	0.06	9.91	9.91	0.20
600	72	32.47	15.15	0.00	29.68	13.92	0.02	26.50	12.59	0.02	22.86	11.15	0.03	18.75	9.64	0.03
	67	27.04	15.91	0.03	24.15	14.58	0.03	20.85	13.15	0.03	17.10	11.62	0.03	12.87	10.02	0.03
	62	22.04	16.54	0.03	19.03	15.12	0.03	15.77	13.66	0.03	12.99	12.99	0.08	11.02	11.02	0.22
675	72	34.94	16.29	0.01	31.98	15.00	0.02	28.57	13.60	0.03	24.67	12.08	0.03	20.26	10.47	0.03
	67	29.15	17.24	0.04	26.08	15.85	0.04	22.53	14.33	0.04	18.50	12.70	0.04	13.93	10.98	0.04
	62	23.81	18.05	0.04	20.61	16.55	0.04	17.10	14.99	0.04	14.24	14.24	0.10	12.08	12.08	0.23
<b>UNIT SIZE 24</b>																
700	72	37.53	18.55	0.01	34.36	17.10	0.03	30.70	15.51	0.03	26.52	13.79	0.04	21.79	11.96	0.04
	67	31.33	19.68	0.04	28.04	18.11	0.04	24.24	16.39	0.04	19.90	14.54	0.04	15.00	12.59	0.04
	62	25.60	20.65	0.04	22.17	18.96	0.04	18.42	17.19	0.04	15.39	15.39	0.10	13.05	13.05	0.24
800	72	40.55	20.05	0.03	37.16	18.53	0.03	33.24	16.86	0.04	28.73	15.04	0.04	23.67	13.10	0.04
	67	33.93	21.49	0.05	30.40	19.83	0.05	26.32	18.01	0.05	21.65	16.05	0.05	16.35	13.94	0.05
	62	27.80	22.74	0.05	24.14	20.96	0.05	20.14	19.08	0.05	17.05	17.05	0.12	14.46	14.46	0.26
900	72	43.24	21.41	0.04	39.65	19.84	0.04	35.50	18.10	0.05	30.72	16.19	0.05	25.36	14.17	0.05
	67	36.24	23.16	0.05	32.51	21.44	0.05	28.19	19.54	0.05	23.22	17.48	0.05	17.59	15.25	0.05
	62	29.76	24.71	0.05	25.92	22.86	0.05	21.74	20.87	0.06	18.61	18.61	0.15	15.79	15.79	0.27
<b>UNIT SIZE 30</b>																
875	72	47.47	21.63	0.00	43.42	19.90	0.02	38.78	18.01	0.03	33.46	15.96	0.03	27.43	13.79	0.03
	67	39.55	22.86	0.03	35.35	20.99	0.03	30.52	18.95	0.04	25.01	16.76	0.04	18.78	14.44	0.04
	62	32.25	23.91	0.04	27.87	21.89	0.04	23.08	19.80	0.04	19.10	19.10	0.09	16.16	16.16	0.23
1000	72	51.44	23.44	0.02	47.10	21.62	0.03	42.11	19.63	0.03	36.37	17.46	0.04	29.88	15.15	0.04
	67	42.96	25.02	0.04	38.45	23.04	0.04	33.25	20.88	0.04	27.29	18.53	0.04	20.53	16.04	0.04
	62	35.12	26.39	0.04	30.43	24.25	0.04	25.29	22.01	0.04	21.21	21.21	0.11	17.95	17.95	0.25
1125	72	54.98	25.09	0.03	50.40	23.21	0.04	45.09	21.12	0.04	38.98	18.84	0.04	32.11	16.42	0.04
	67	46.01	27.02	0.05	41.24	24.96	0.05	35.71	22.69	0.05	29.36	20.23	0.05	22.15	17.58	0.05
	62	37.70	28.72	0.05	32.76	26.51	0.05	27.36	24.14	0.05	23.22	23.22	0.13	19.66	19.66	0.27
<b>UNIT SIZE 36</b>																
1050	72	54.59	26.69	0.02	50.01	24.65	0.03	44.72	22.40	0.04	38.64	19.95	0.04	31.78	17.34	0.04
	67	45.63	28.59	0.04	40.86	26.37	0.04	35.36	23.92	0.04	29.04	21.27	0.04	21.87	18.44	0.05
	62	37.33	30.25	0.05	32.38	27.85	0.04	26.97	25.31	0.05	22.73	22.73	0.12	19.24	19.24	0.26
1200	72	58.74	28.79	0.03	53.86	26.67	0.04	48.22	24.31	0.05	41.71	21.72	0.05	34.40	18.98	0.05
	67	49.21	31.17	0.05	44.13	28.84	0.05	38.25	26.27	0.05	31.48	23.46	0.05	23.80	20.44	0.05
	62	40.37	33.27	0.05	35.14	30.77	0.05	29.44	28.08	0.06	25.15	25.15	0.14	21.30	21.30	0.27
1350	72	62.40	30.69	0.04	57.27	28.51	0.05	51.32	26.07	0.05	44.43	23.37	0.06	36.70	20.51	0.06
	67	52.38	33.56	0.06	47.03	31.15	0.06	40.83	28.47	0.06	33.69	25.54	0.06	25.56	22.36	0.06
	62	43.07	36.12	0.06	37.62	33.54	0.06	31.73	30.70	0.07	27.42	27.42	0.17	23.25	23.25	0.29

**Table 12 – Estimated Sound Power Level (dBA)**

<b>FMA ESTIMATED SOUND PRESSURE LEVEL</b>					
<b>Unit Size</b>	<b>kbtu</b>	<b>18</b>	<b>24</b>	<b>30</b>	<b>36</b>
Indoor sound pressure level	dBA High	50	54	54	54

<b>UNIT SIZE</b>	<b>CONDITIONS</b>		<b>OCTAVE BAND CENTER FREQUENCY</b>						
	<b>CFM</b>	<b>Ext Static Pressure</b>	<b>63</b>	<b>125</b>	<b>250</b>	<b>500</b>	<b>1000</b>	<b>2000</b>	<b>4000</b>
18	600	0.25	46	52.1	48.9	51.8	52.5	51.7	49.7
24	800	0.25	54.1	57.1	58.6	59	61.5	59.8	57
30	1000	0.25	51.6	52.6	52.6	53.3	56.1	52.8	59.7
36	1200	0.25	52.6	52.3	54.6	54.3	57.2	53.8	50.4

\* Estimated sound power levels have been derived using the method described in the 1987 ASHRAE HVAC Systems & Applications Handbook, Chapter 52, p. 52.7.

**Table 13 – Electrical Data for Fan Coil with Electric Heat – Combined Electrical Data**

<b>Nominal Fan Coil Capacity</b>	<b>Nominal Heat Capacity @ 240V</b>	<b>Minimum Circuit Ampacity (MCA)</b>		<b>MAX.Fuse or Breaker Heat Kit (HACR) Ampacity</b>	
MBTU	KW	208	240	208	240
18, PSC	5	23.6	27.1	30	30
	7.5	34.9	40.1	45	45
	10	46.2	53.1	60	60
24, PSC	5	23.9	27.3	30	30
	7.5	35.2	40.4	45	45
	10	46.4	53.4	60	60
30, PSC	5	24.2	27.7	30	30
	7.5	35.5	40.7	45	45
	10	46.8	53.7	60	60
36, PSC	5	24.9	28.3	30	30
	7.5	36.2	41.4	45	45
	10	47.4	54.4	60	60
18, ECM	5	25.0	28.5	30	30
	7.5	36.3	41.5	45	45
	10	47.6	54.5	60	60
24, ECM	5	25.0	28.5	30	30
	7.5	36.3	41.5	45	45
	10	47.6	54.5	60	60
30, ECM	5	26.0	29.5	30	30
	7.5	37.3	42.5	45	45
	10	48.6	55.5	60	60
36, ECM	5	26.0	29.5	30	30
	7.5	37.3	42.5	45	45
	10	48.6	55.5	60	60



**Table 14 – Electrical Data for FMA5L – PSC Motor Units with Electric Heat Installed**

Heat Kit Model	Used on Unit Size	Nominal Heat Capacity @ 240V	Shipping Weight	Heater Capacity (MBH)		Minimum Circuit Ampacity (MCA)		MAX. Fuse or Breaker Heat-Kit Ampacity (HACR)		Min Wire Size (AWG) ††		Min Ground Wire Size		Max Wire Length (Ft) ‡‡	
				KW	lbs. (kg)	208	240	208	240	208	240	208	240	208	240
EHK205B	18	5	5.1 (2.3)	12.3	16.4	23.6	27.1	30	30	10	10	10	10	73	74
EHK208B		7.5		19.2	25.6	34.9	40.1	50	50	8	8	10	10	76	77
EHK210B		10		24.6	32.8	46.2	53.1	60	60	6	6	10	10	92	92
EHK205B	24	5	5.1 (2.3)	12.3	16.4	23.9	27.3	30	30	10	10	10	10	73	73
EHK208B		7.5		19.2	25.6	35.2	40.4	50	50	8	8	10	10	76	76
EHK210B		10		24.6	32.8	46.4	53.4	60	60	6	6	10	10	91	92
EHK205B	30	5	5.1 (2.3)	12.3	16.4	24.2	27.7	30	30	10	10	10	10	72	72
EHK208B		7.5		19.2	25.6	35.5	40.7	50	50	8	8	10	10	75	76
EHK210B		10		24.6	32.8	46.8	53.7	60	60	6	6	10	10	91	91
EHK205B	36	5	5.1 (2.3)	12.3	16.4	24.9	28.3	30	30	10	10	10	10	70	71
EHK208B		7.5		19.2	25.6	36.2	41.4	50	50	8	8	10	10	74	74
EHK210B		10		24.6	32.8	47.4	54.4	60	60	6	6	10	10	90	90

\* †† Copper wire must be used. If other than uncoated (non-plated), 75°C ambient, copper wire (solid wire for 10 AWG and smaller, stranded wire for larger than 10 AWG) is used, consult applicable tables of the National Electric Code (ANSI/NGPA 70).

\* ‡‡ Length shown is as measured 1 way along wire path between unit and service panel for a voltage drop not to exceed 2%.

**Table 15 – Electrical Data for FMA5X – ECM Motor Units with Electric Heat Installed**

Heat Kit Model	Used on Size	Nominal Heat Capacity @ 240V	Shipping Weight	Heater Capacity (MBH)		Minimum Circuit Ampacity (MCA)		MAX. Fuse or Breaker Heat-Kit Ampacity (HACR)		Min Wire Size (AWG) ††		Min Ground Wire Size		Max Wire Length (Ft) ‡‡	
				KW	lbs. (kg)	208	240	208	240	208	240	208	240	208	240
EHK205B	18	5	5.1 (2.3)	12.3	16.4	25	28.5	30	30	10	10	10	10	69	70
EHK208B		7.5		19.2	25.6	36.3	41.5	50	50	8	8	10	10	73	74
EHK210B		10		24.6	32.8	47.6	54.5	60	60	6	6	10	10	89	90
EHK205B	24	5	5.1 (2.3)	12.3	16.4	25	28.5	30	30	10	10	10	10	69	70
EHK208B		7.5		19.2	25.6	36.3	41.5	50	50	8	8	10	10	73	74
EHK210B		10		24.6	32.8	47.6	54.5	60	60	6	6	10	10	89	90
EHK205B	30	5	5.1 (2.3)	12.3	16.4	26	29.5	30	30	10	10	10	10	67	68
EHK208B		7.5		19.2	25.6	37.3	42.5	50	50	8	8	10	10	71	72
EHK210B		10		24.6	32.8	48.6	55.5	60	60	6	6	10	10	87	88
EHK205B	36	5	5.1 (2.3)	12.3	16.4	26	29.5	30	30	10	10	10	10	67	68
EHK208B		7.5		19.2	25.6	37.3	42.5	50	50	8	8	10	10	71	72
EHK210B		10		24.6	32.8	48.6	55.5	60	60	6	6	10	10	87	88

\* †† Copper wire must be used. If other than uncoated (non-plated), 75°C ambient, copper wire (solid wire for 10 AWG and smaller, stranded wire for larger than 10 AWG) is used, consult applicable tables of the National Electric Code (ANSI/NGPA 70).

\* ‡‡ Length shown is as measured 1 way along wire path between unit and service panel for a voltage drop not to exceed 2%.

**Table 16 – Other Accessories**

<b>Kit Number</b>	<b>Description</b>	<b>Used on sizes</b>
AMWK001WG	Louvered Wall Panel with Frame (6 pack)	18, 24
AMWK002WG	Louvered Wall Panel with Frame (6 pack)	30, 36
KSATX0201PUR	TXV Kit, Puron Advance	18, 24, 30
KSATX0301PUR	TXV Kit, Puron Advance	36
KFARA0110LGL	Return Air Opening Grille (10 pack)	18, 24
KFARA0210LGL	Return Air Opening Grille (10 pack)	30, 36
KFAET0150ETK	PVC Condensate Trap Kit (50 pack)	ALL