

Installation and Venting Instructions

NOTE: See Table 1 for Furnace Models allowed to be used with this kit.

NOTE: Read the entire instruction manual before starting the installation. **KEEP THESE INSTRUCTIONS WITH THE FURNACE.**

CAUTION

PERSONAL INJURY HAZARD

Failure to follow this caution may result in personal injury.

C.S.A. design-certified furnaces for use with chimney adapter kits on masonry chimneys are identified on their rating plates. These markings identify which chimney adapter kit number is permitted to be used with each furnace model number. Chimney adapter kits are for use with **ONLY** furnaces having factory-authorized chimney adapter kit numbers marked on the furnaces.

These kits are permitted to be used with only the following furnace models (See Table 1). Do not use this kit with any other furnace models.

SAFETY CONSIDERATIONS

WARNING

FIRE, EXPLOSION, ELECTRICAL SHOCK AND CARBON MONOXIDE POISONING HAZARD

Failure to follow instructions could result in personal injury, death or property damage.

Improper installation, adjustment, alteration, service, maintenance, or use can cause carbon monoxide poisoning, explosion, fire, electrical shock, or other conditions, which could cause personal injury or property damage. Consult a qualified service agency, local gas supplier, or your distributor or branch for information or assistance. The qualified service agency must use only factory-authorized and listed kits or accessories when modifying this product.

Installing and servicing heating equipment can be hazardous due to gas and electrical components. Only trained and qualified personnel should install, repair, or service heating equipment.

Untrained personnel can perform basic maintenance functions such as cleaning and replacing air filters. All other operations must be performed by trained service personnel. When working on heating equipment, observe precautions in the literature, on tags, and on labels attached to or shipped with the unit, and other safety precautions that may apply.

Follow all safety codes. In the United States, follow all safety codes including the National Fuel Gas Code (NFGC) NFPA 54/ANSI Z223.1.

Wear safety glasses and work gloves. Have a fire extinguisher available during start-up, adjustment procedures, and service calls.

Recognize safety information. This is the safety-alert symbol . When you see this symbol on the furnace and in instructions or manuals, be alert to the potential for personal injury.

Understand the signal words **DANGER**, **WARNING**, **CAUTION**, and **NOTE**. The words **DANGER**, **WARNING**, and **CAUTION** are used with the safety-alert symbol. **DANGER** identifies the most serious hazards which will result in severe personal injury or death. **WARNING** signifies hazards which could result in personal injury or death. **CAUTION** is used to identify unsafe practices which would result in minor personal injury, or product and property damage. **NOTE** is used to highlight suggestions which will result in enhanced installation, reliability, or operation.

MASONRY CHIMNEY APPLICATIONS

These kits and furnaces shall be applied in accordance with the following section titled Chimney Adapter Application Requirements. The Masonry Chimney Application Requirements section with Tables 9 and 10 inside the back page of this instruction identifies a very small number of exterior masonry chimney applications that are permitted without the use of the chimney adapter kit.

CHIMNEY ADAPTER APPLICATION REQUIREMENTS

This chimney adapter kit is permitted in accordance with NFGC as an **ALTERNATIVE VENTING DESIGN**. The requirements that follow in part A apply to both single-furnace and multiple-appliance applications. After completing part A, continue to part B for a single furnace application, or continue to part C for a multiple appliance application. After completing part B or C, continue to the **INSTALLATION OF CHIMNEY ADAPTER** section.

A. SINGLE FURNACE and MULTIPLE APPLIANCES

(Single furnace, and single furnace and draft hood-equipped water heater(s) vented into a chimney.)

1. This kit is permitted to be used in any building in which the space surrounding the furnace is not depressurized by more than 0.02 In. W.C. (5Pa) below outdoor pressure by equipment such as exhaust fans and clothes dryers.
2. Temperature of air surrounding furnace and vent connector(s) shall be 60°F (42°C) or warmer.
3. Furnace rating plate is marked with kit number that is permitted to be used.
4. Chimney construction shall be in good condition and shall conform to the Standard for Chimneys, Fireplaces, Vents, and Solid Fuel Burning Appliances NFPA 211 in the United States. See Chimney Inspection Chart later in the manual.

5. High altitude: Although appliance input is derated starting at 2000 ft altitude, use sea level input for all altitudes in this chimney sizing instruction.
6. Furnace vent connector lateral length, clay tile liner size, and chimney height shall conform to Table 2.
7. Maintain required clearance to combustible materials. See furnace for Minimum-Clearances-to-Combustible-Construction label, which includes minimum clearance to chimney adapter.

8. Appliance application and operation has significant impact on successful chimney performance. Follow furnace installation instructions in general and, in particular, the APPLIANCE APPLICATION REQUIREMENTS in the VENTING REQUIREMENTS section. See the NFGC or authority having jurisdiction for all other venting requirements.

Table 1 – Kit Usage

KIT PART NO.	FURNACE MODEL	FURNACE SIZE USED WITH			
KGACA02014FC	MODELS: 58 STA / STX / DLA / DLX / CTA / CTW / CTX / CTY / CVA / CVX / PHA / PHB / PHX / PHY TN / TP / SP / SB / SC	045-08 045-12	070-08 070-12 070-16	090-14 090-16 090-20	110-12 110-16 110-20 110-22
	MODELS: 310 / 311 / 312 / 313 / 314 / 315 AAV / JAV / ABV / JBV MODELS: PG8 MAA / JAA / MEA / JEA / JEB / MVA / JVA / JVB 880TA / 881TA / 820TA / 821TA 820SA / 821SA / 800SA / 801SA 810SA / 811SA MODELS: PG80 VTL / ESA / ESL	24045 36045	24070 36070 48070	42090 48090 60090	36110 48110 66110
KGACA02015FC	MODELS: 58 STA / STX / DLA / DLX / CTA / CTW / CTX / CTY / CVA / CVX / PHA / PHB / PHX / PHY TN / TP / SP / SB / SC	135-16 135-20 135-22	155-20 155-22	—	
	MODELS: 310 / 311 / 312 / 313 / 314 / 315 AAV / JAV / ABV / JBV MODELS: PG8 MAA / JAA / MEA / JEA / JEB / MVA / JVA / JVB 880TA / 881TA / 820TA / 821TA 820SA / 821SA / 800SA / 801SA 810SA / 811SA MODELS: PG80 VTL / ESA / ESL	48135 60135 66135	60155 66155	—	

The furnace and kit combinations are C.S.A. design-certified as ALTERNATIVE VENTING DESIGNS.

Table 2 – Chimney Requirements

FURNACE MODEL SIZES	CHIMNEY ADAPTER KIT NUMBER	FURNACE VENT CONNECTOR LATERAL MAXIMUM LENGTH FT (M)	CHIMNEY CLAY TILE LINER MAXIMUM NOMINAL SIZE OR INSIDE AREA IN OR IN ² (MM or MM ²)	CHIMNEY MAXIMUM HEIGHT FT (M)
MODELS 310 / 311 / 312 / 313 / 314 / 315 AAV / JAV / ABV / JBV & 880TA / 881TA / 820TA / 821TA 820SA / 821SA / 800SA / 801SA 810SA / 811SA 58STA / STX / PHA / PHX / DLA / DLX / CTA / CTW / CTX / CTY / CVA / CVX / PHB / PHY / TN / TP / SP / SB / SC PG8MAA / JAA / MEA / JEA / MVA / JVA / JVB / JEB & PG80 VTL / ESA / ESL				
24045 / 045–08	KGACA02014FC	9 (3)	8 X 8 or 42.7 (203 X 203 or 27548)	30 (9)
	KGACA02014FC	9 (3)	8 X 12 or 63.6 (203 X 305 or 41032)	25 (8)
36045 / 045–12	KGACA02014FC	9 (3)	8 X 8 or 42.7 (203 X 203 or 27548)	30 (9)
	KGACA02014FC	9 (3)	8 X 12 or 63.6 (203 X 305 or 41032)	25 (8)
24070 / 070–08	KGACA02014FC	9 (3)	8 X 8 or 42.7 (203 X 203 or 27548)	30 (9)
	KGACA02014FC	9 (3)	8 X 12 or 63.6 (203 X 305 or 41032)	25 (8)
36070 / 070–12	KGACA02014FC	9 (3)	8 X 8 or 42.7 (203 X 203 or 27548)	30 (9)
	KGACA02014FC	9 (3)	8 X 12 or 63.6 (203 X 305 or 41032)	25 (8)
48070 / 070–16	KGACA02014FC	9 (3)	8 X 8 or 42.7 (203 X 203 or 27548)	30 (9)
	KGACA02014FC	9 (3)	8 X 12 or 63.6 (203 X 305 or 41032)	25 (8)
42090 / 090–14	KGACA02014FC	9 (3)	8 X 12 or 63.6 (203 X 305 or 41032)	35 (11)
48090 / 090–16	KGACA02014FC	9 (3)	8 X 12 or 63.6 (203 X 305 or 41032)	35 (11)
60090 / 090–20	KGACA02014FC	9 (3)	8 X 12 or 63.6 (203 X 305 or 41032)	35 (11)
36110 / 110–12*	KGACA02014FC	9 (3)	8 X 12 or 63.6 (203 X 305 or 41032)	35 (11)
48110 / 110–16	KGACA02014FC	9 (3)	8 X 12 or 63.6 (203 X 305 or 41032)	35 (11)
60110 / 110–20	KGACA02014FC	9 (3)	8 X 12 or 63.6 (203 X 305 or 41032)	35 (11)
66110 / 110–22	KGACA02014FC	9 (3)	8 X 12 or 63.6 (203 X 305 or 41032)	35 (11)
48135 / 135–16*	KGACA02015FC	10 (3)	12 X 12 or 83.3 (305 X 305 or 53742)	35 (11)
60135 / 135–20*	KGACA02015FC	10 (3)	12 X 12 or 83.3 (305 X 305 or 53742)	35 (11)
66135 / 135–22*	KGACA02015FC	10 (3)	12 X 12 or 83.3 (305 X 305 or 53742)	35 (11)
60155 / 155–20*	KGACA02015FC	10 (3)	12 X 12 or 83.3 (305 X 305 or 53742)	35 (11)
66155 / 155–22*	KGACA02015FC	10 (3)	12 X 12 or 83.3 (305 X 305 or 53742)	35 (11)

*Chimney must be minimum height specified in the furnace installation instructions.

Table 3 – Permitted Chimney Location

MINIMUM 99% WINTER DESIGN TEMPERATURE*	PERMITTED CHIMNEY LOCATION
–25°F (–32°C) or Warmer	Interior Masonry Chimney†
+17°F (–8°C) or Warmer	Exterior Masonry Chimneys‡

* The 99% Winter Design Dry–Bulb (db) temperatures may be found in the ASHRAE Fundamentals Handbook and NFPA54/ANSI Z 223.1 also provides winter design temperatures for some locations.

†Chimneys not exposed to the outdoors below the roof–line.

‡Chimneys with one or more sides exposed to the outdoors below the roof line.

CHIMNEY INSPECTION CHART

For additional requirements refer to the National Fuel Gas Code NFPA 54/ANSI Z223.1 and ANSI/NFPA 211 Chimneys, Fireplaces, Vents, and Solid Fuel Burning Appliances

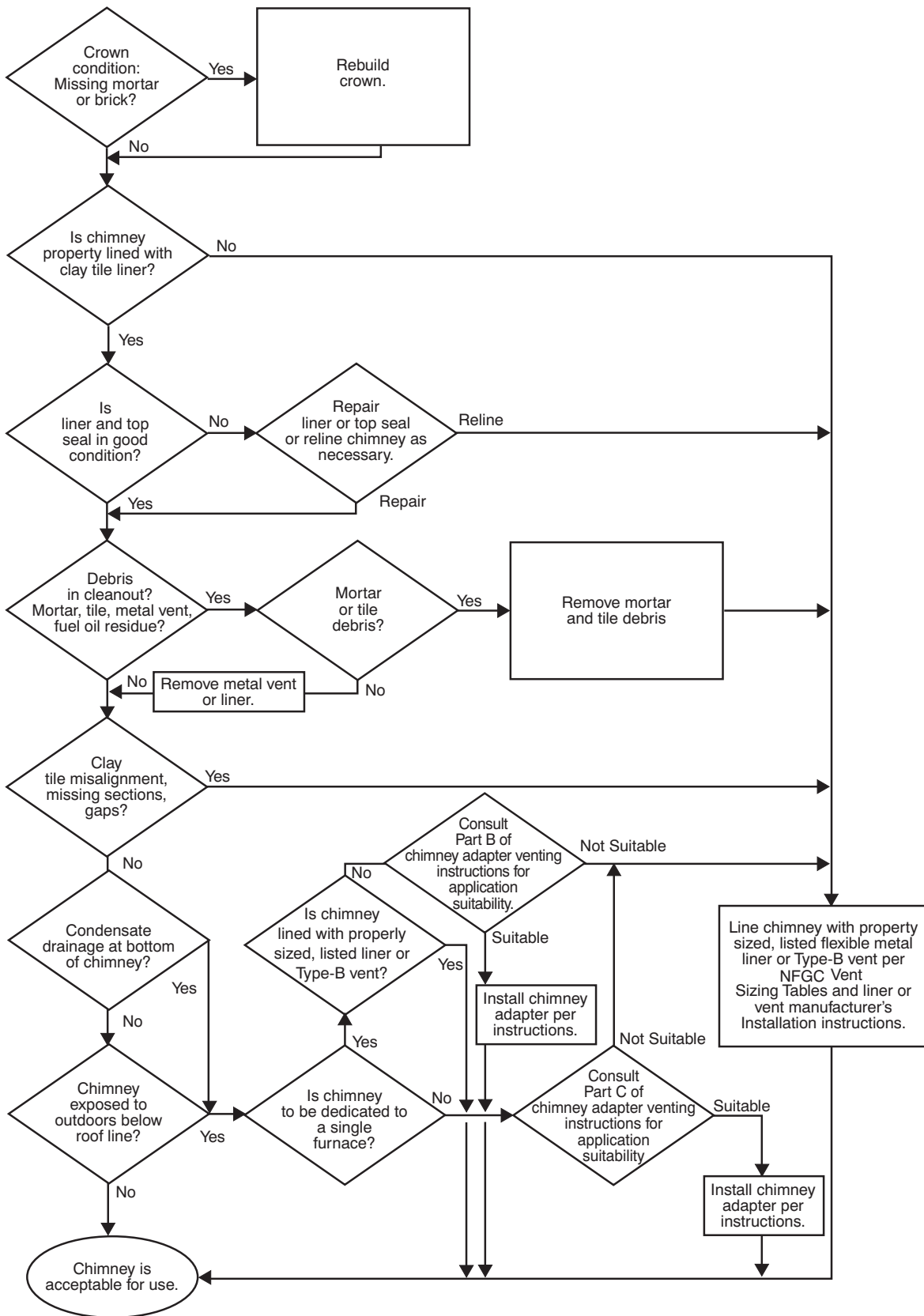

Table 4 – Single-Furnace - Masonry Chimney Flue Capacity with Type-B Double-Wall Vent Connector

VENT HEIGHT H FT (M)	LATERAL L FT (M)	MINIMUM "NAT MAX" INTERNAL AREA OF MASONRY CHIMNEY FLUE, SQUARE IN.					
		28	38	50	63	78	95
		FURNACE INPUT RATING IN THOUSANDS OF BTU PER HOUR					
		NAT	NAT	NAT	NAT	NAT	NAT
6 (2)	2 (.6)	86	130	180	247	320	401
	5 (2)	82	117	165	231	298	376
8 (2)	2 (.6)	93	145	198	266	350	446
	5 (2)	88	134	183	247	328	423
	8 (2)	83	127	175	239	318	410
10 (3)	2 (.6)	103	162	221	298	388	491
	5 (2)	96	148	204	277	365	466
	10 (3)	87	139	191	263	347	444
15 (5)	2 (.6)	114	179	250	336	441	562
	5 (2)	107	164	231	313	416	513
	10 (3)	97	153	216	296	394	567
20 (6)	2 (.6)	124	201	274	375	491	627
	5 (2)	116	184	254	350	463	597
	10 (3)	107	172	237	332	440	566
30 (9)	2 (.6)	137	216	303	421	558	717
	5 (2)	128	198	281	393	526	683
	10 (3)	115	184	236	373	500	648
35 (11)	2 (.6)	143	168	315	435	577	741
	5 (2)	134	206	291	406	544	706
	10 (3)	121	192	273	386	517	669

NOTE: Table 4 was extracted from "NAT Max" columns in Table 13.1(c) in Chapter 13 of NFPA54/ANSI Z223.1 in United States.

Table 5 – Permitted Vent Material

MINIMUM 99% WINTER DESIGN TEMPERATURE*	CHIMNEY LOCATION	FURNACE VENT CONNECTOR MATERIAL	WATER HEATER VENT CONNECTOR MATERIAL
-25°F (-32°C) to -10° (-23°C)	Interior Masonry Chimneys†	Listed Type-B Double-Wall Metal Pipe	Listed Type-B Double-Wall Metal Pipe or Single-Wall Galvanized Steel Pipe
	Exterior Masonry Chimneys‡	Not Permitted	Not Permitted
-10°F (-23°C) or Warmer	Interior Masonry Chimneys†	Listed Type-B Double-Wall Metal Pipe or Single-Wall Galvanized Steel Pipe	Listed Type-B Double-Wall Metal Pipe or Single-Wall Galvanized Steel Pipe
	Exterior Masonry Chimneys‡	Listed Type-B Double-Wall Metal Pipe	Listed Type-B Double-Wall Metal Pipe or Single-Wall Galvanized Steel Pipe

* The 99% Winter Design Dry-Bulb (db) temperatures may be found in the ASHRAE Fundamentals Handbook and NFPA54/ANSI Z 223.1 also provides winter design temperatures for some locations.

†Chimneys not exposed to outdoors below roof-line.

‡Chimneys with 1 or more sides exposed to outdoors below roof-line.

Table 6 – Max Water Heater Input

VENT HEIGHT H – FT (M)	6 (2)			8 (2.5)			10 (3)			15 (4.5)			20 (6)			30 (9)			50 (15)			100 (30)			
	1	2	3	1	2	3	1	2	3	1	2	3	1	2	3	1	2	3	1	2	3	1	2	3	
4-inch dia. (102 mm) Connector Rise R Ft. (M)	.3	.6	.9	.3	.6	.9	.3	.6	.9	.3	.6	.9	.3	.6	.9	.3	.6	.9	.3	.6	.9	.3	.6	.9	
Water Heater Maximum Input Rating in Thousands of BTU per Hour	B	40	52	61	41	53	62	42	54	63	44	55	64	46	56	65	48	58	66	51	61	69	50	60	68
	S	39	52	61	40	52	62	41	53	62	43	54	63	45	57	65	47	57	65	50	60	68	49	59	67

B=Listed Type-B Double-Wall metal pipe. S=Single-Wall galvanized-steel pipe.

These rise requirements are based on NFGC and NSCPGIC.

Table 7 – Minimum Masonry Chimney Internal Area (Multiple Appliances)

Vent Height H Ft. (M)	MINIMUM "NAT+NAT" INTERNAL AREA OF MASONRY CHIMNEY FLUE, SQ. IN. (SQ. MM)					
	28 (18064)	38 (24516)	50 (32258)	63 (40645)	78 (50322)	113 (72903)
	Combined Appliance Maximum Input Rating in Thousands of Btu per Hour					
	NAT +NAT	NAT +NAT	NAT +NAT	NAT +NAT	NAT +NAT	NAT +NAT
6 (2)	NP	103	143	188	246	NP
8 (2)	NP	119	163	218	278	408
10 (3)	NP	131	177	236	302	454
15 (5)	106	152	212	283	365	546
20 (6)	122	172	243	325	419	648
30 (9)	137	198	278	381	496	749
35 (11)	NP	NP	291	401	524	792

NP – Not Permitted

Table 8 – Permitted Exceptions to Minimum 99% Winter Design Temperature and Furnace Connector Diameter

Furnace Model Sizes	Chimney Clay Tile Liner Nominal Size or Inside Area In. or Sq. In (mm or Sq. mm)								
	8 x 8 or 42.7 (203 x 203 or 27548)			8 x 12 or 63.6 (203 x 305 or 41032)			12 x 12 or 83.3 (305 x 305 or 53742)		
	Furnace Type—B Vent Connector Diameter In. (mm)								
	6 (152)	5 (127)	4 (102)	6 (152)	5 (127)	4 (102)	7 (178)	6 (152)	5 (127)
MODELS 310 / 311 / 312 / 313 / 314 / 315 AAV / JAV / ABV / JBV and 58STA / STX / PHA / PHX / DLA / DLX / CTA / CTW / CTX / CVA / CVX / CTY / PHB / PHY and TN / TP / SP / SB / SC and 880TA / 881TA / 820TA / 821TA 820SA / 821SA / 800SA / 801SA 810SA / 811SA and PG8MAA / JAA / MEA / JEA / MVA / JVA / JVB / JEB and PG80 VTL / ESA / ESL									
24045 / 045-08	NOT PERMITTED								
36045 / 045-12	NOT PERMITTED								
24070 / 070-08	NOT PERMITTED								
36070 / 070-12	-10 (-23)‡	-10 (-23)	+5 (15)*	-10 (-23)**††	-10 (-23)	-10 (-23)*	NP	NP	NP
48070 / 070-16	NOT PERMITTED								
42090 / 090-14	NOT PERMITTED								
48090 / 090-16	-10 (-23)††	-10 (-23)†	NP	-10 (-23)††	-10 (-23)†	NP	NP	NP	NP
60090 / 090-20	NOT PERMITTED								
36110 / 110-12	NOT PERMITTED								
48110 / 110-16	-10 (-23)‡	NP	NP	-10 (-23)‡	NP	NP	NP	NP	NP
60110 / 110-20	NOT PERMITTED								
66110 / 110-22	NOT PERMITTED								
48135 / 135-16	NOT PERMITTED								
60135 / 135-20	-10 (-23)*†,††	NP	NP	-10 (-23)**††	NP	NP	-10 (-23)††	-10 (-23)*	NP
66135 / 135-22	NOT PERMITTED								
60155 / 155-20	NOT PERMITTED								
66155 / 155-22	NP	NP	NP	NP	NP	NP	-10 (-23)‡	NP	NP
MODELS 393AAV and 58YAV									
024070 / 070-8	-10 (-23)‡	-10 (-23)	+5 (15)*	-10 (-23)**††	-10 (-23)	-10 (-23)*	NP	NP	NP
036070 / 070-12	NOT PERMITTED								
042091 / 091-14	-10 (-23)††	-10 (-23)†	NP	-10 (-23)††	-10 (-23)†	NP	NP	NP	NP
048111 / 111-16	-10 (-23)‡	NP	NP	-10 (-23)‡	NP	NP	NP	NP	NP
060135 / 136-20	-10 (-23)*†,††	NP	NP	-10 (-23)**††	NP	NP	-10 (-23)††	-10 (-23)*	NP
060155 / 155-20	NP	NP	NP	NP	NP	NP	-10 (-23)‡	NP	NP

NP = Not Permitted

Temperatures in parentheses are Celsius temperatures.

* Furnace connector rise shall be at least 3 ft. (.9 M)

† Chimney height shall be at least 10 ft. A higher chimney height is required, if the furnace installation instructions specify a higher chimney height.

‡ Furnace connector rise shall be at least 2 ft or chimney height shall be at least 15 ft. (5 M)

** 6-in. X 5-in. (152 X 127 mm) or 6-in. X 4-in. (152 X 102 mm) tapered furnace vent connector deceiver is permitted at chimney inlet opening. However, better resistance to chimney condensation will result, if connector diameter is not reduced.

†† 4-in. X 3-in. (102 X 76 mm) tapered water heater vent connector deceiver is permitted at chimney inlet opening. However, better resistance to chimney condensation will result, if connector diameter is not reduced.

‡‡ Either ** or †† is permitted, but not both.

B. SINGLE FURNACE

(Single furnace without a draft hood-equipped water heater vented into a chimney.)

1. The 99 percent winter design temperature* shall determine permitted locations for clay tile - lined masonry chimneys as shown in Table 3:
2. Type - B double - wall metal vent (with up to 4 elbows) shall be used exclusively for furnace vent connector.
3. Furnace vent connector shall be same size as Chimney Adapter outlet.
4. See Table 2 for maximum length of furnace vent connector lateral.

NOTE: See Fig. 1 while reviewing the following requirements.

5. The minimum chimney size shall conform to Table 4.
6. See Table 2 for maximum chimney size and maximum chimney height.

C. MULTIPLE APPLIANCES

(Single furnace common-vented with a draft hood-equipped water heater(s) into a chimney.)

1. The minimum 99 percent winter design temperature* and chimney location shall determine permitted vent connector material as shown in Table 5:
2. Furnace vent connector rises shall not exceed 3 ft. (.9M)
3. An operational draft hood-equipped water heater shall be common-vented with furnace. Additional draft hood-equipped appliances are permitted to be common-vented with furnace.
4. Each vent connector is permitted up to 4 elbows.
5. Furnace vent connector shall be same size as Chimney Adapter outlet.
6. Water heater vent connector shall be 4-in. (102 mm) diameter with no more than 6 ft. (2 M) of lateral (horizontal connector length), with water heater draft hood outlet sizes of 3- and 4-in. (76 and 102 mm) diameter. Use a 3- X 4-in. (76 X 102 mm) vent increaser with a 3-in. (76 mm) draft hood outlet.
7. Water heater gas inputs* shall not exceed the rates as shown in Table 6.

NOTE: See Fig. 1 while reviewing the following requirements.

8. Minimum chimney size shall conform to "NAT+NAT" columns for common vent capacity in Table 13.2c in of NFPA54/ANSI Z223.1 in United States. The chimney sizing requirements in Table 7 were extracted from these codes.
9. Permitted exceptions to -10°F (-23°C) minimum 99 percent winter design temperature and furnace connector diameters are provided in Table 8. If Table 8 permits a furnace connector size that is smaller than the chimney adapter outlet, a tapered deceiver is permitted at the chimney adapter outlet.
10. Manifolder common-vent connectors: See NFPA54/ANSI Z223.1 in USA. For chimney heights of 8 ft or more, Type-B manifolded common-vent connectors with no elbows are permitted. The manifolded common-vent connector diameter shall be 1 in. (25 mm) greater than required furnace vent connector size. The combined horizontal length of longest vent connector (furnace or water heater) plus manifolded common-vent connector shall not exceed vent connector lateral specified in section A.6. Each connector is permitted up to 2 elbows. No exceptions from Table 8 are permitted. The minimum winter design temperature permitted with manifolded common-vent connector is -10°F (-23°C).

INSTALLATION OF CHIMNEY ADAPTER

1. Turn off gas supply at manual gas valve before turning off electric power supply to furnace.

WARNING

ELECTRICAL SHOCK, FIRE OR EXPLOSION HAZARD

Failure to follow this warning could result in personal injury or death or property damage.

Before installing, modifying or servicing system, main electrical disconnect switch must be in the OFF position and install a lockout tag. There may be more than one disconnect switch. Lock out and tag switch with a suitable warning label. Verify proper operation after servicing.

2. Turn off electric power supply to furnace at disconnect switch.
3. The chimney adapters must always be installed for vertical flow of vent gas from bottom to top of chimney adapter.
4. UPFLOW AND HORIZONTAL AIR-FLOW APPLICATIONS NOT NEEDING STRAIGHT VENT PIPE INTERNAL TO FURNACE
KIT NO. KGACA02014FC: Attach chimney adapter to furnace flue elbow with 2 sheet metal screws (field-supplied) through two 1/8-in. (3 mm) holes at inlet (small end) of chimney adapter. (See Fig. 2 or 3.)
KIT NO. KGACA02015FC: Use same procedure as above, except a standard 4-in. dia. to 5-in. dia. (102 to 127 mm) vent pipe increaser (field-supplied) is required between furnace elbow and chimney adapter.
DOWNFLOW AND HORIZONTAL AIR-FLOW APPLICATIONS HAVING A STRAIGHT VENT PIPE INTERNAL TO FURNACE
KIT NO. KGACA02014FC: Complete installation of flue pipe (and elbows) to exit furnace casing. If downflow furnace flue pipe exits casing through lower-left door opening, route the flue pipe through an accessory vent guard external to the casing. Attach chimney adapter to furnace flue where it exits the furnace casing or vent guard with three sheet metal screws (field-supplied) through two factory-punched 1/8-in. (3 mm) holes and a third field-drilled 1/8-in. (3 mm) hole at inlet (small end) of chimney adapter. Third hole should be 90° from other two holes.
KIT NO. KGACA02015FC: Use same procedure as above for KGACA02014FC, except a standard 4-in. dia.-to-5-in. (102 to 127 mm) dia. vent pipe increaser (field-supplied) is required between the furnace flue and the chimney adapter.
5. Remove lock nut from fitting on free end of electrical conduit attached to chimney adapter. Route wire ends through a 7/8-in. (22 mm) hole in furnace casing near the chimney adapter. Secure conduit to furnace with lock nut. If Vent Guard is used on downflow furnace, cut a notch in Vent Guard flange to provide access to 7/8-in. (22 mm) hole in furnace casing for conduit attachment.
6. See furnace wiring label for wiring connections. Find furnace red wires that connect to draft safeguard switch (DSS). Disconnect red wire with insulated, female, 3/16-in. (8 mm) quick-connect terminal from DSS, and connect this red wire to orange wire from blocked vent shutoff switch (BVSS) of chimney adapter that has insulated, male, 3/16-in. (8 mm) quick-connect terminal. Male and female 3/16-in. (8 mm) terminals must be oriented so that insulators fit together. Connect other chimney adapter BVSS orange wire to DSS terminal from

which red wire was disconnected. Position orange wire terminal similar to remaining red wire terminal on DSS so that orange wire is directed away from hot elbow. The BVSS should be in series with the DSS.

NOTE: For applications where the chimney adapter wire leads will not reach the DSS, use the factory-supplied extension wires between the chimney adapter BVSS leads and the DSS. A metal wire-routing clip is included in the kit to secure the orange extension wires away from hot surfaces and rotating parts.

7. No other wire connection changes should be made for chimney adapter. Be certain that no terminals can be shorted to other circuits or to any grounded parts.
8. Refer to Fig. 1. Secure a Type-B draft hood connector to top of chimney adapter with 3 sheet metal screws (field-supplied). Install Type-B double-wall metal vent connector from draft hood connector to chimney flue opening in accordance with vent pipe manufacturer's Installation Instructions. The horizontal portion of venting system shall maintain a minimum of 1/4-in. upward slope per linear foot away from furnace, and shall be rigidly supported every 5 ft. or less with hangers and straps to ensure that there will be no movement after installation. The connector shall conform to size, rise, and lateral requirements under Venting Requirements and Table 2 of these instructions. Do NOT use the NFGC or NSCNPGIC vent connector sizing requirements.
9. Complete installation of water heater Type-B double-wall vent connector in same manner as used for furnace connector, except that a chimney adapter is not required at Type-B draft hood connector for water heater. (Not required for single appliance, Venting Requirements Section B.)

START-UP, ADJUSTMENT, AND SAFETY CHECK

1. Complete Start-Up, Adjustment, and Safety Check in furnace Installation Instructions. Adjust furnace air temperature rise to be near high end of air temperature rise range specified on furnace rating plate (without exceeding high end of rise range). A higher air temperature rise reduces chimney condensation. While doing furnace check, the following steps shall be performed with each appliance that is connected to common vented chimney. Put each appliance in operation while other appliance(s) are not in operation.
 - a. Inspect venting system for blockage or restriction, leakage, corrosion, and other deficiencies that could cause an unsafe condition.
 - b. Insofar as practical, close all building doors and windows, and all doors between space in which appliances are located and other spaces of building. Turn on clothes

dryer and any appliance not connected to this chimney flue. Turn on all exhaust fans such as range hoods and bathroom exhausts, so they will operate at maximum speed. Do not operate a summer exhaust fan. Close fireplace dampers.

- c. Follow operating instructions for each appliance being checked. Adjust each thermostat so appliance will operate continuously.
 - d. Test for vent gas spillage at water heater draft hood (when applicable) and at furnace chimney adapter relief openings after 5 minutes of main burner operation. Use the flame of a match or candle.
 - e. Operate ALL appliances that are common-vent connected to chimney flue, and again test for vent gas spillage.
 - f. If improper venting is observed during any of above tests (e.g., vent gas spillage at water heater draft hood or furnace chimney adapter, or leakage from vent system), the common-venting chimney system must be corrected.
 - g. After it has been determined that each appliance properly vents when tested as outlined above, return doors, windows, exhaust fans, fireplace dampers, and any other gas-burning appliances to their previous conditions of use.
2. Check chimney adapter BVSS. This test is required, in addition to the test of the DSS required by the furnace installation instructions. The purpose of the BVSS is to cause safe shutdown of furnace, if furnace vent connector or chimney becomes blocked.
 - a. Disconnect power to furnace, and remove vent connector from chimney adapter. Be sure to allow time for vent pipe to cool down before handling pipe.
 - b. Place jumper wire across DSS terminals to electrically by-pass DSS so that if DSS opens, furnace does not shut-down until BVSS opens.
 - c. Restore power to furnace and set room thermostat 5°F (-15°C) above room temperature.
 - d. After normal start-up, allow furnace to operate for 2 minutes, then block chimney adapter outlet 100 percent. Furnace should shut off within 2 minutes.
 - e. REMOVE JUMPER WIRE FROM DRAFT SAFEGUARD SWITCH!
 - f. Remove blockage and reconnect vent connector to chimney adapter.
 - g. Wait 5 minutes, then reset BVSS and DSS.
 3. With furnace blower operating, check for air leakage from supply-air plenum or coil casing that could interfere with BVSS operation. If air leaks are found they must be properly sealed.
 4. Leave Installation Instructions for chimney adapter and for furnace near furnace.

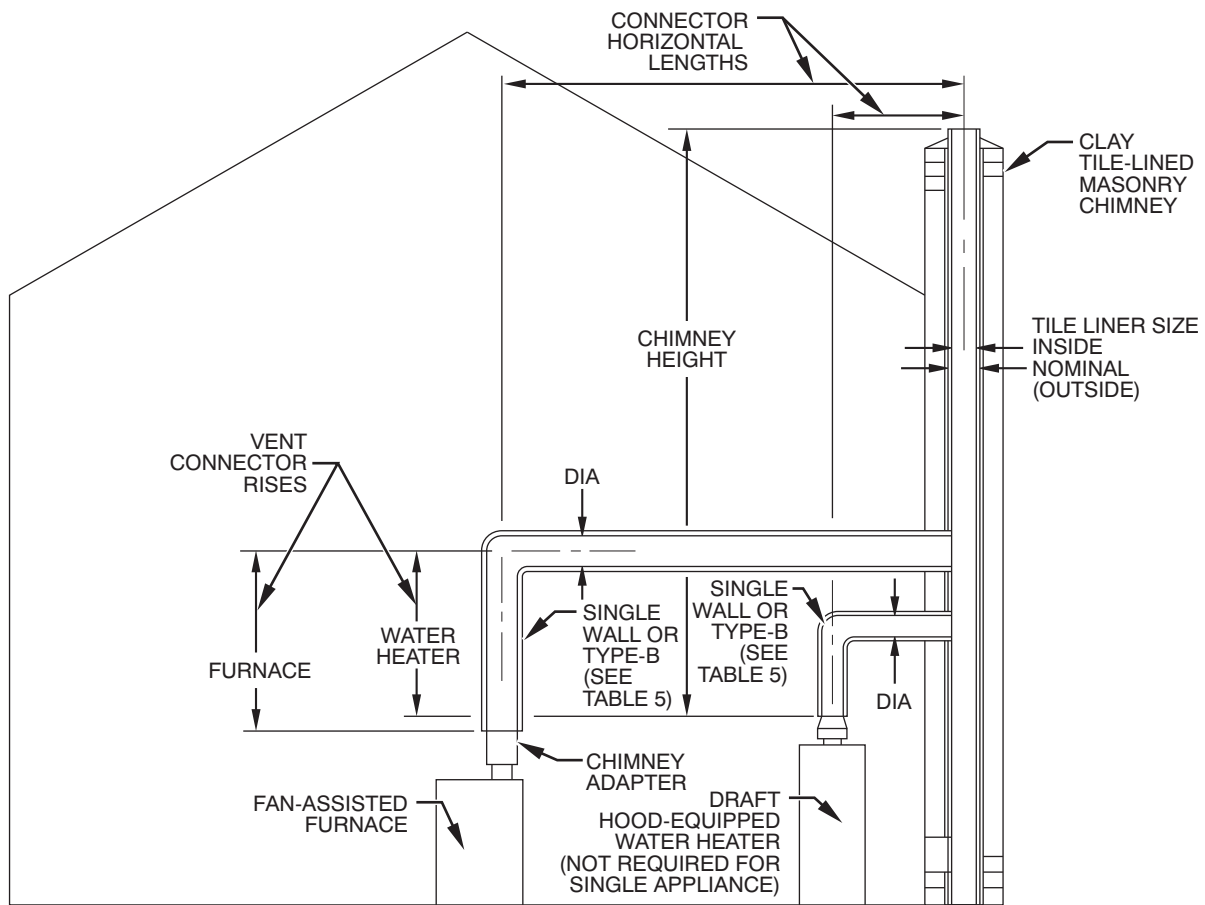
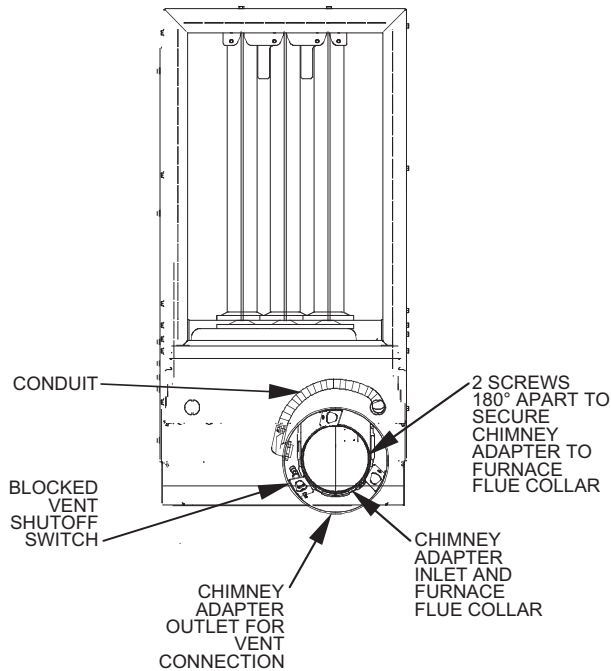

Fig. 1 - Furnace and Water Heater Vent Connectors, Chimney Adapter, and Chimney

A97515



A10233

Fig. 2 - Chimney Adapter Secured to Upflow Furnace Flue Collar (Sizes up through 110,000 Btuh input)

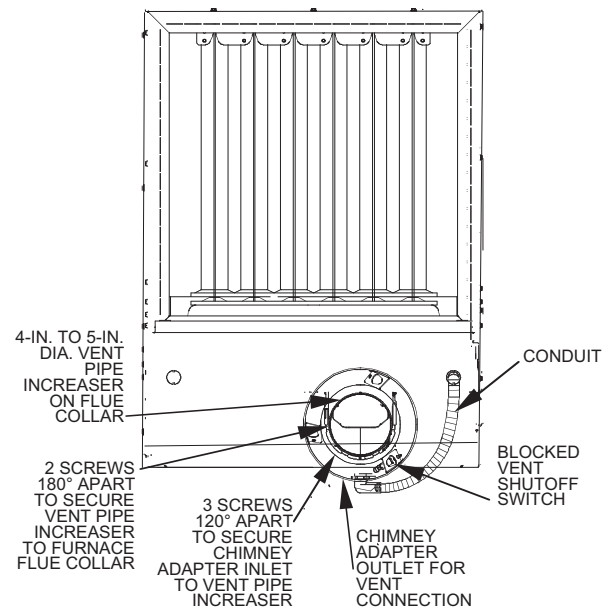

A10234

Fig. 3 - Chimney Adapter Secured to Upflow Furnace Flue Collar (Sizes of 132,000 and 154,000 Btuh input)

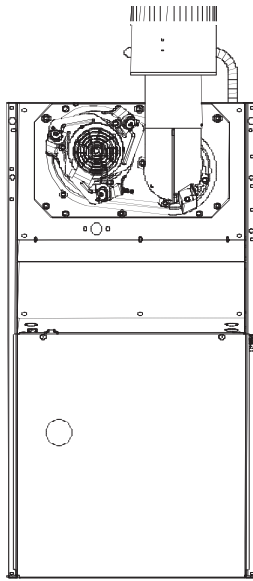

A08193
Fig. 4 - Chimney Adapter Secured to Upflow Furnace Flue Collar

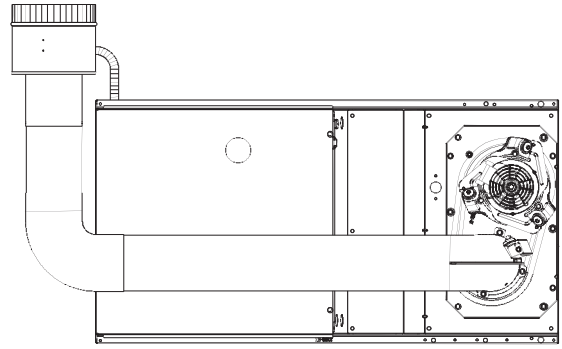

A08196
Fig. 6 - Chimney Adapter Secured to Flue Collar, Internal Flue Pipe, and Vent Elbow on Horizontal-Right Furnace

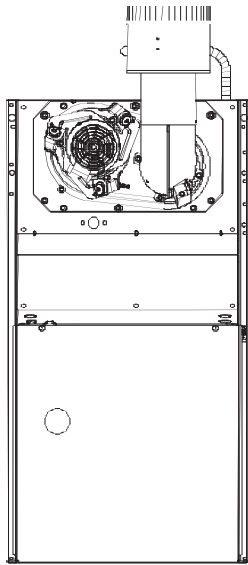

A08194
Fig. 5 - Chimney Adapter Secured to Upflow Furnace Flue Collar (Sizes of 132,000 and 154,000 Btuh input)

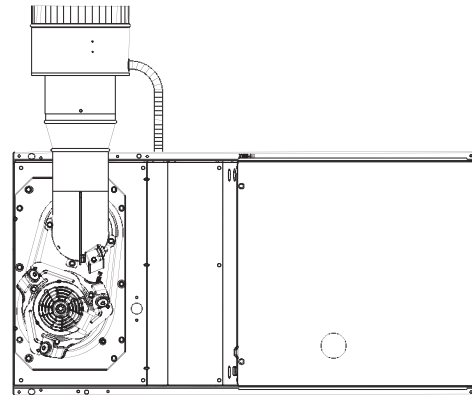

A08195
Fig. 7 - Chimney Adapter Secured to Upflow Furnace Flue Collar

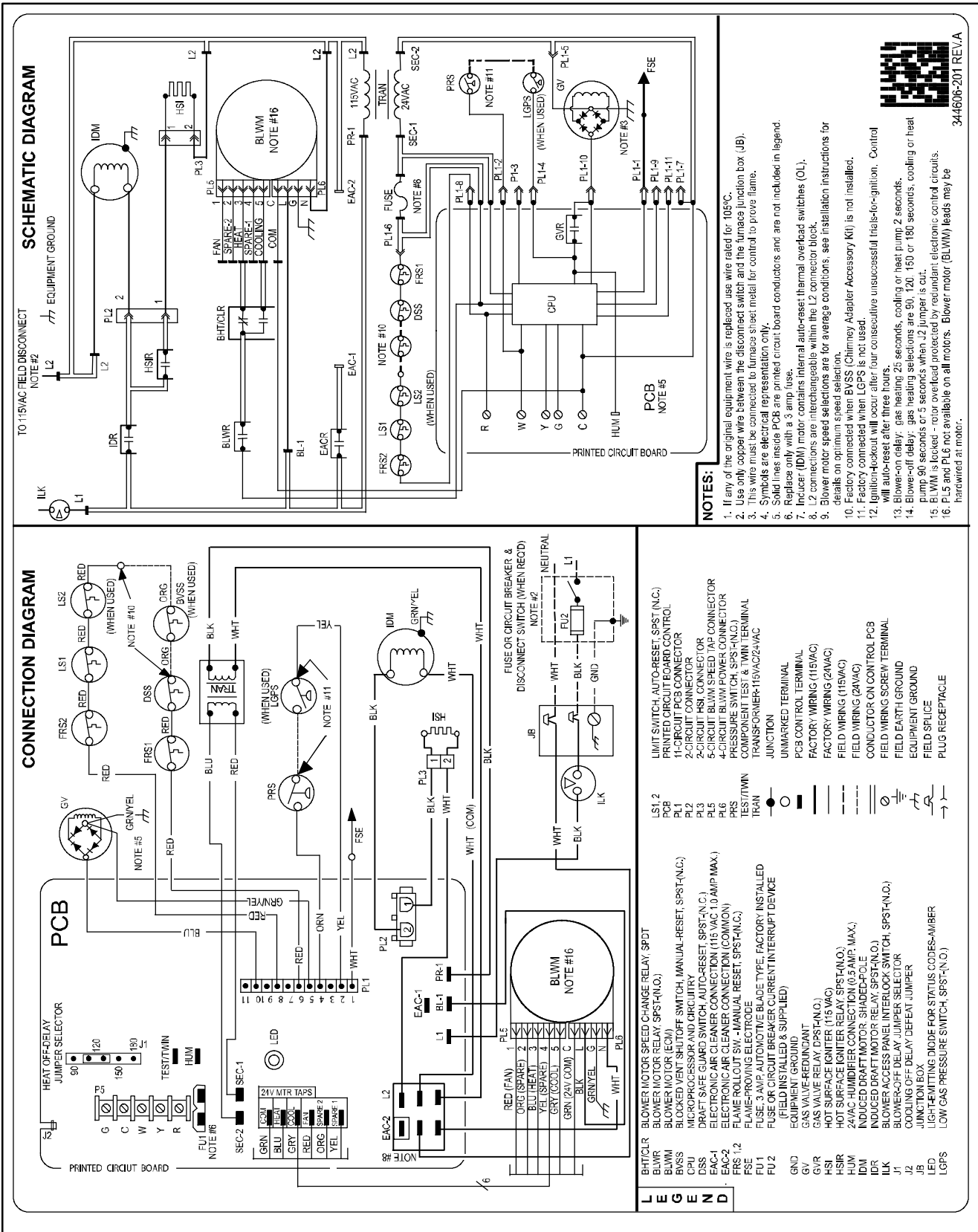

Fig. 8 - Example of Single-Stage Furnace Wiring Diagram.
NOTE: Reference wiring diagram affixed to furnace or in electrical section of the installation instructions.



344606-201 REV.A

MASONRY CHIMNEY APPLICATION REQUIREMENTS

If a clay tile-lined masonry chimney is used, an alternative venting design might be required, such as a listed chimney lining system or this listed chimney adapter kit. ONE OF THE FOLLOWING METHODS SHALL BE USED TO DETERMINE IF AN ALTERNATIVE VENTING DESIGN IS NOT REQUIRED.

In the USA - Refer to Masonry Chimney Sections of NFPA54/ANSI Z223.1 or the authority having jurisdiction to determine whether relining is required. If relining is required, use a properly sized listed metal liner, Type-B vent, or a listed alternative venting design, such as this listed chimney adapter kit (with a furnace listed for use with this kit), a listed chimney lining system, or a Type-B common vent.

A 78 or 80 percent AFUE, hot surface ignition, Category I, fan-assisted furnace is permitted to be vented into a clay tile-lined masonry chimney that is exposed to the outdoors below the roof line, provided:

Multiple Appliances - (A single furnace common-vented with a draft hood-equipped water heater(s) into a chimney.)

1. Vent connector is Type-B double-wall, and
2. The furnace is common vented with at least one draft hood-equipped appliance, and
3. The combined appliance input rating is less than the maximum capacity given in Table 9, and
4. Input rating of each space heating appliance is greater than minimum input rating given in Table 10 and
5. The authority having jurisdiction approves.

If all of these conditions cannot be met, an alternative venting design is required, such as this listed chimney adapter kit (with a furnace listed for use with this kit), a listed chimney lining system, or a Type-B common vent.

Single Appliance - (A single furnace vented into a chimney.) - Category I, fan assisted furnaces without draft hoods are not permitted to be vented into clay tile-lined masonry chimneys that are exposed to the outdoors below the roof line.

Table 9 – Combined Appliance Maximum Input Rating in Thousands of Btu per Hr

VENT HEIGHT FT (M)	INTERNAL AREA OF CHIMNEY IN. ² (mm ²)			
	12 (7742)	19 (12258)	28 (18064)	38 (24516)
6 (1.8)	74	119	178	257
8 (2.4)	80	130	193	279
10 (3)	84	138	207	299
15 (5)	NR	152	233	334
20 (6)	NR	NR	250	368
30 (9)	NR	NR	NR	404

Table 10 – Minimum Allowable Input Rating of Space-Heating Appliances in Thousands of Btu per Hr

	VENT HEIGHT FT. (M)	INTERNAL AREA OF CHIMNEY IN. ² (mm ²)			
		12 (7742)	19 (12258)	28 (18064)	38 (24516)
17 to 26°F (-8 to -3°C)		Local 99% Winter Design Temperature: 17 to 26°F (-8 to -3°C)*			
	6 (2)	0	55	99	141
	8 (2)	52	74	111	154
	10 (3)	NR	90	125	169
	15 (5)	NR	NR	167	212
	20 (6)	NR	NR	212	258
	30 (9)	NR	NR	NR	362
5 to 16°F (-15 to -9°C)		Local 99% Winter Design Temperature: 5 to 16°F (-15 to -9°C)*			
	6 (2)	NR	78	121	166
	8 (2)	NR	94	135	182
	10 (3)	NR	111	149	198
	15 (5)	NR	NR	193	247
	20 (6)	NR	NR	NR	293
	30 (9)	NR	NR	NR	377
-10 to 4°F (-23 to -16°C)		Local 99% Winter Design Temperature: -10 to 4°F (-23 to -16°C)*			
	6 (2)	NR	NR	145	196
	8 (2)	NR	NR	159	213
	10 (3)	NR	NR	175	231
	15 (5)	NR	NR	NR	283
	20 (6)	NR	NR	NR	333
	30 (9)	NR	NR	NR	NR
-11°F or lower (-24°C or lower)		Local 99% Winter Design Temperature: -11°F or lower (-24°C or lower)* Not recommended for any vent configuration			

*The 99% Winter Design Dry-Bulb (db) temperatures maybe found in the ASHRAE Fundamentals Handbook.

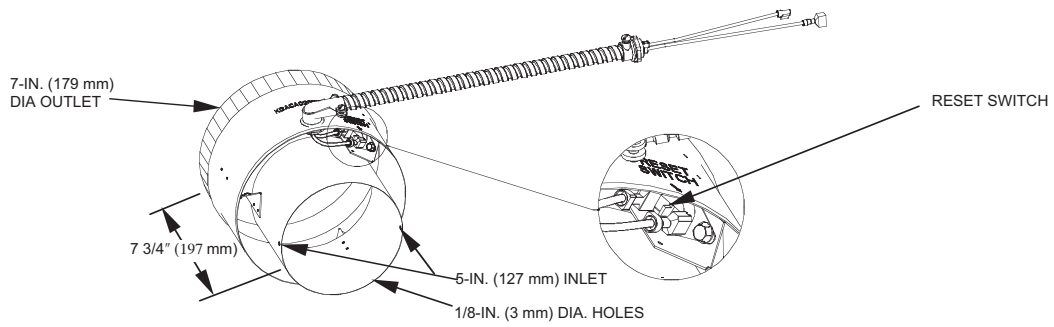

KGACA02015FC

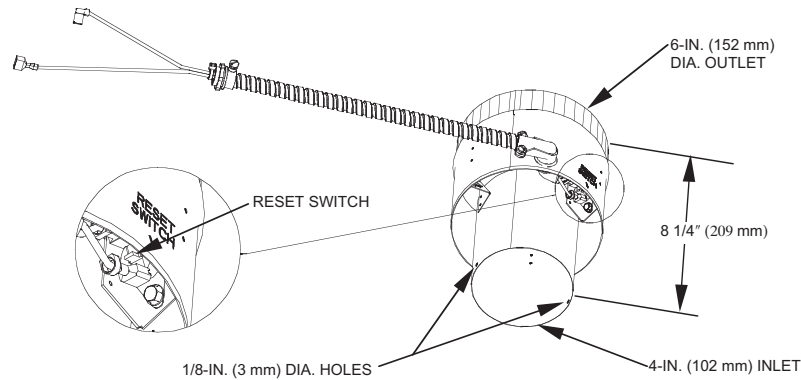

KGACA02014FC

A08240

Fig. 9 - Chimney Adapters

SERVICE TRAINING

Packaged Service Training programs are an excellent way to increase your knowledge of the equipment discussed in this manual, including:

- Unit Familiarization • Maintenance
- Installation Overview • Operating Sequence

A large selection of product, theory, and skills programs is available, using popular video-based formats and materials. All include video and/or slides, plus companion book.

Classroom Service Training plus "hands-on" the products in our labs can mean increased confidence that really pays dividends in faster troubleshooting, fewer callbacks. Course descriptions and schedules are in our catalog.

CALL FOR FREE CATALOG 1-800-644-5544

[] Packaged Service Training [] Classroom Service Training

A94328

