

## CNPHP

### Cased N Coil, Horizontal Heating – Cooling

## Installation Instructions

**NOTE:** Read the entire instruction manual before starting the installation.

### SAFETY CONSIDERATIONS

Improper installation, adjustment, alteration, service, maintenance, or use can cause explosion, fire, electrical shock or other conditions which may cause death, personal injury or property damage. Consult a qualified installer, service agency, or your distributor or branch for information or assistance. The qualified installer or agency must use factory-authorized kits or accessories when modifying this product. Refer to the individual instructions packaged with the kits or accessories when installing.

Follow all safety codes. Wear safety glasses, protective clothing and work gloves. Use quenching cloths for brazing operations. Have fire extinguisher available. Read these instructions thoroughly and follow all warnings or cautions attached to the unit. Consult local building codes and the current editions of the National Electrical Codes (NEC) NFPA 70.

In Canada, refer to the current editions of the Canadian Electrical Code CSA C22.1.

Recognize safety information. This is the safety-alert symbol . When you see this symbol on the unit and in instructions or manuals, be alert to the potential for personal injury.

Understand the signal words DANGER, WARNING and CAUTION. These words are used with the safety-alert symbol. DANGER identifies the most serious hazards which will result in severe personal injury or death. WARNING signifies hazards which could result in personal injury or death. CAUTION is used to identify unsafe practices, which may result in minor personal injury or product and property damage. NOTE is used to highlight suggestions which will result in enhanced installation, reliability, or operation.

**NOTE:** Nitrogen can leak out through the needle pierce hole in the plugs. This does not indicate a leaking coil nor warrant return of the coil.

### WARNING

#### ELECTRICAL SHOCK HAZARD

Failure to follow this warning could result in personal injury or death. Before installing, modifying or servicing system, always turn off main power to system. There may be more than one disconnect switch. Lock out and tag switch with a suitable warning label.

### CAUTION

#### PERSONAL INJURY HAZARD

Failure to follow this caution may result in personal injury. This coil contains Nitrogen precharge of 15 PSIG. Release of this pressure through the center of the rubber plugs is required before removing the plugs.

### CAUTION

#### CUT HAZARD

Failure to follow this caution may result in personal injury. Sheet metal parts may have sharp edges or burrs. Use care and wear appropriate protective clothing and gloves when handling parts.

### CAUTION

#### UNIT OR PROPERTY DAMAGE HAZARD

Failure to follow this caution may result in property damage. Take precautions to ensure Aluminum tubes do not come in direct contact or allow for condensate run off with a dissimilar metal. Dissimilar metals can cause galvanic corrosion and possible premature failure.

### CAUTION

#### ENVIRONMENTAL HAZARD

Failure to follow this caution may result in environmental damage. Federal regulations require that you do not vent refrigerant to the atmosphere. Recover during system repair or final unit disposal.

### INTRODUCTION

The CNPHP is a horizontal, multi-use furnace coil ([Fig. 1](#)). With the use of field-supplied transition duct, these furnace coils can also be applied to other similar horizontal furnaces on the market. The coil is available in sizes 024 through 060. All models are equipped with a factory-installed TXV and are used with Puron® (R-410A) refrigerant systems.

## INSTALLATION

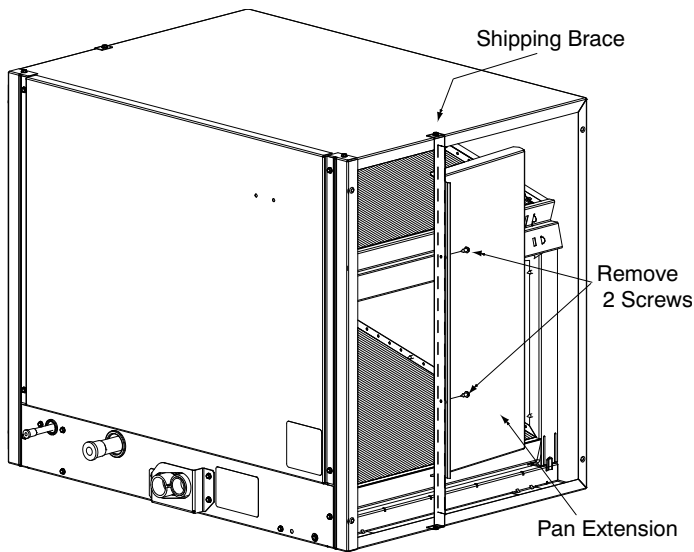

Fig. 1 – Furnace Coil

A06031

CNPHP furnace coils are NOT designed to be installed with furnaces that measure wider than the coil itself.

Before installation, there are several other performance requirements that must be considered because poor installation can negatively alter performance. The following section will briefly discuss those factors.

### Airflow

Airflow amount and distribution are vital to adequate system performance. Problems that can be experienced with incorrect airflow include:

- low system performance
- restricted TXV
- frosted coil
- poor humidity control
- water blow-off

**NOTE:** In addition, heat pump applications require airflow in a particular direction for best performance. See decal on front of coil for correct direction.

When attaching the coil and building the plenum, pay special attention to the effect these details will have on airflow. After system start-up, check the cfm to insure that it is correct. (Generally, the cfm should be 350 to 400 cfm/ton during normal cooling operation.)

### TXV

A thermal expansion valve is utilized in this coil design to optimize performance and comfort throughout the entire operating range of the system. Special attention needs to be taken to the TXV when installing the coil

- Do not overheat valve. Temperatures that exceed 212°F (100°C) can harm valve performance. Use a wet cloth or heat sink when brazing.
- Place liquid filter dryer near ID unit to reduce the risk of debris clogging the valve.
- Make sure TXV bulb is securely fastened and wrapped in the indentation on vapor line tube.

CNPHP Models:

These coils have a factory-installed hard-shutoff TXV designed only for use with R-410A refrigerant. Use only with outdoor units designed for R-410A.

**NOTE:** All TXV'S have preset superheat settings and are not field-adjustable.

### Cabinet Sweating

If the unit is installed in a garage, attic, or other unconditioned space, special attention may need to be given to the potential of cabinet sweating.

### Condensate Management

With proper installation, these coils will manage the condensate without blow-off into the duct work. The 43, 60, and 61 size coils require the addition of a pan extension for both horizontal left and horizontal right position, which is supplied with the coils. See detailed instructions for more info. Also, refer to Connect Condensate Drain Line section of this instruction.



**CAUTION**

### PROPERTY DAMAGE HAZARD

Failure to follow this caution may result in property damage.

When installing over a finished ceiling and/or living area, install a field-fabricated secondary condensate pan under the entire unit.

### HORIZONTAL-RIGHT AND HORIZONTAL-LEFT WITH PAN EXTENSION (43, 60, and 61 Sizes Only)

There are two separate pan extensions shipped with the unit. For horizontal left installations, use the pan attached to the left shipping bracket. For horizontal right installations, use the pan attached to the right shipping bracket. Be sure to use the correct pan extension for the application. There should not be any gaps between the plastic condensate pan and the pan extension. All condensate should flow from the pan extension to the plastic condensate pan and not leak into the coil cabinet or duct.

**NOTE:** Discard the pan not used and both shipping brackets.

For horizontal-left installation, install pan extension onto left end of horizontal-condensate pan. Pan extension is slotted to fit onto condensate pan edge and will extend into supply plenum (Fig. 2).

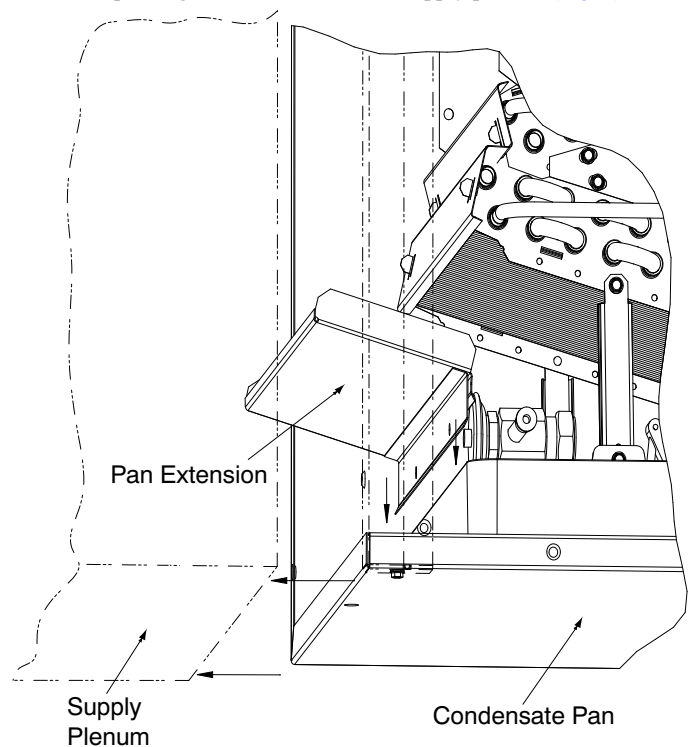
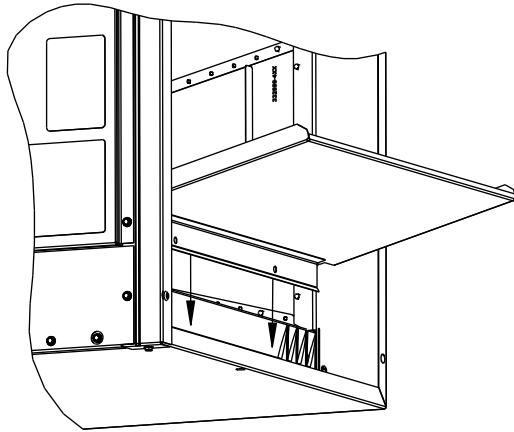

Fig. 2 – Horizontal-Left Installation of Pan Extension (43, 60 & 61 sizes only)

A06032

For horizontal-right, install pan extension onto right end of horizontal-condensate pan. Pan extension is slotted to fit onto condensate pan edge and will extend into supply plenum (Fig. 3).



**Fig. 3 – Horizontal-Right Installation of Pan Extension**  
(43, 60, & 61 sizes only)

A09084

These units can be installed in multiple configurations. To ensure proper performance of the system, install and orientate the components as shown in Fig. 4. Use Table 1 and Table 2 to identify which Application Letters (A through J) are acceptable for the furnace width and coil width being used in a specific situation. Orientate and configure the furnace and coil as shown in each application.

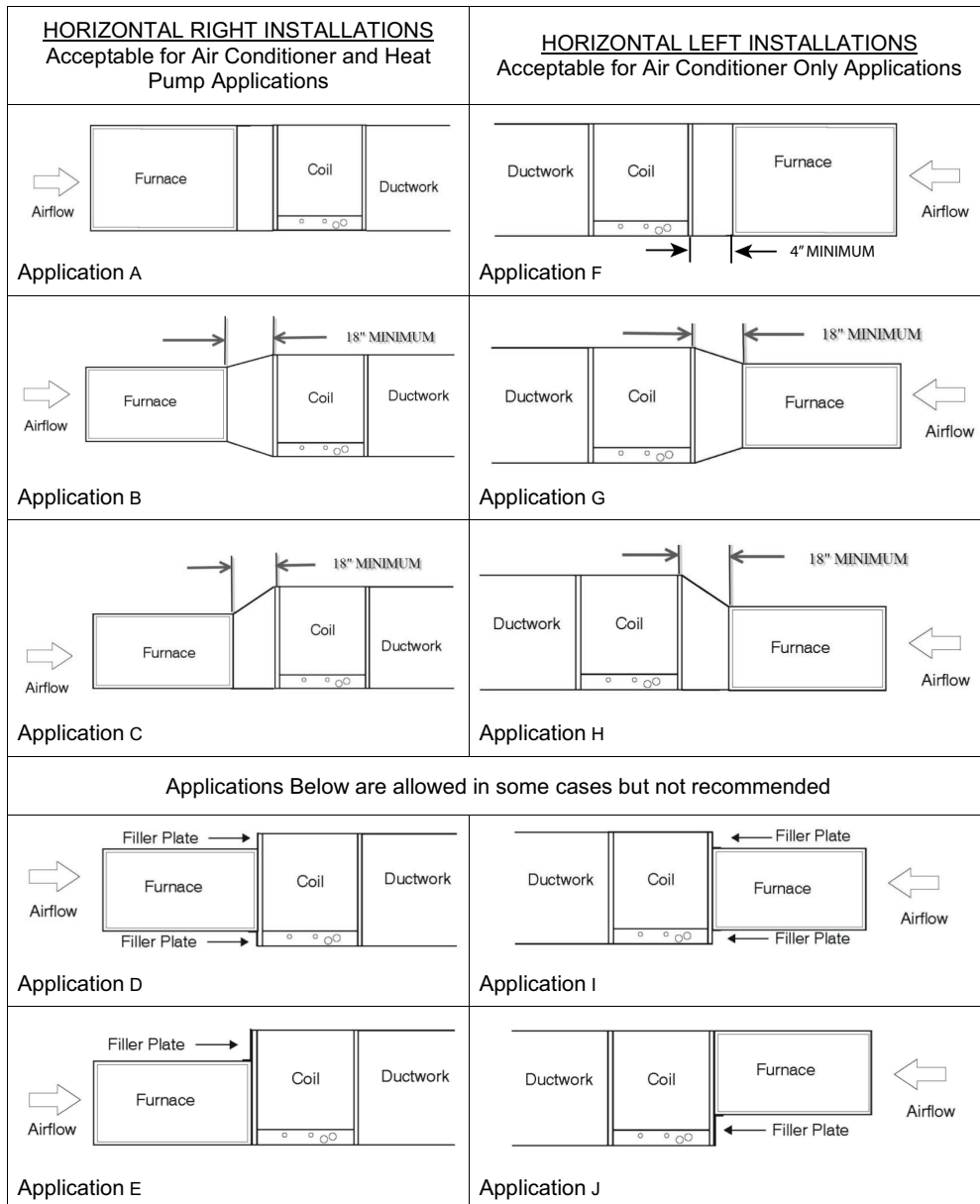

**Fig. 4 – Horizontal Installation Applications**

A180215A

**Table 1 – Heat Pump Right Hand Applications**

Furnace Width- In. (mm)	Coil Width- In. (mm)		
	17.5 (445)	21 (533)	24.5 (622)
14 (356)	B, C	[B,C]	
17.5 (445)	A	B, C, [D, E]	[B,C]
21 (533)		A	B, C, [D, E]
24.5 (622)			A

NOTE: Applications inside [ ] allowed but not recommended. Grey area not permitted.

**Table 2 – Air Conditioner Applications**

Furnace Width- In. (mm)	Coil Width- In. (mm)		
	17.5 (445)	21 (533)	24.5 (622)
14 (356)	B, C, G, H	[B,C,G,H]	
17.5 (445)	A, F	B,C,G,H [D,E,I,J]	[B,C,G,H]
21 (533)		A, F	B,C,G,H [D,E,I,J]
24.5 (622)			A, F

NOTE: Applications inside [ ] allowed but not recommended. Grey area not permitted.

**Installation Configurations**

These units can be installed on a work platform, secured to roof trusses in the attic, suspended from hangers on floor joists in the crawl space, or installed on blocks. See proper section and figures for detailed installation instructions.

**NOTE:** Pan extension is needed for both horizontal left and right applications. **DO NOT DISCARD.**

**FURNACE ATTACHMENT**

**Attach coil to furnace**

The attachment plates (3) and filler plate (1) are packaged together and placed in the coil carton. Remove these items, verifying the number of pieces. Use the following procedure to attach CNPHP horizontal coil to furnace.

**NOTE:** Remove shipping brace from both ends of casing prior to installation. Also remove corrugated shipping block from inside the right end of casing prior to installation.

1. Three attachment plates are used to attach coil to furnace. Application determines which end of the coil will be attached to the furnace.
2. Use self-tapping screws to mount attachment plates to coil casing (Fig. 5).

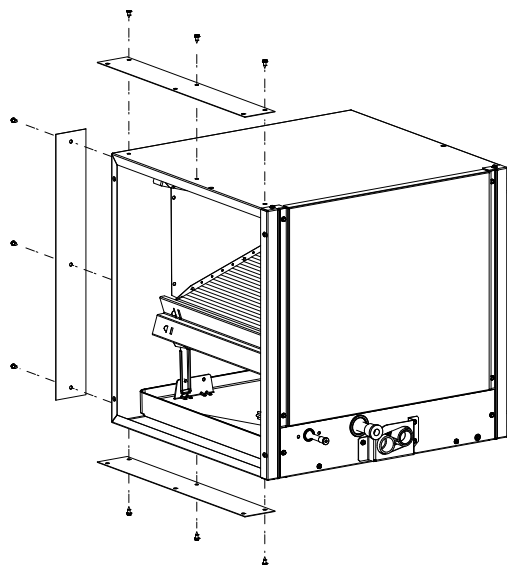

**Fig. 5 – Mount Attachment Plates**

A05419

3. Connect furnace snugly against coil casing.
4. Use self-tapping screws to attach furnace (Fig. 6).
5. Seal joint between coil casing and furnace to create air-tight seal using locally-approved materials.

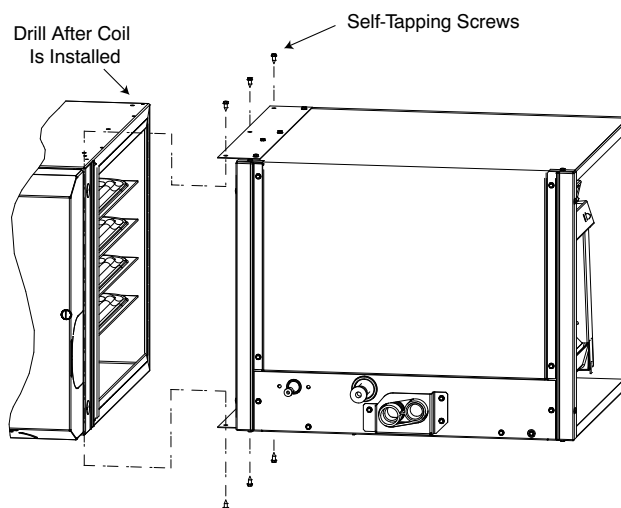

**Fig. 6 – Attach Coil to Furnace**

A05420

**NOTE:** If the coil and furnace are different widths, refer to Fig. 4 and Table 1 & Table 2.

**HORIZONTAL ATTIC INSTALLATION**

**Construct work platform to support coil/furnace combination**

1. Construct work platform, using material in platform that will support the weight of an installer or a service person.
2. Place work platform in front of discharge end of furnace.
3. Secure platform to building joists.

**Install coil**

To suspend CNPHP:

1. Cut metal plumbers strap to desired lengths.
2. Attach metal plumbers strap to four corners of coil casing (Fig. 7).
3. Use a minimum of two screws per corner to attach plumbers strap to casing.
4. Position and secure coil in front of furnace discharge end.
5. Make sure coil is level for proper condensate drainage.
6. Using appropriate fasteners for duct type, connect supply-air duct to coil.

## HORIZONTAL CRAWL SPACE INSTALLATION

As an alternate to horizontal attic installation, the CNPHP horizontal coil can be installed in a crawl space by mounting on suitable blocks, pads or by hanging from floor joists.

To suspend CNPHP:

1. Cut metal plumbers strap to desired lengths.
2. Attach metal plumbers strap to four corners of coil casing (Fig. 7).
3. Use a minimum of two screws per corner to attach metal plumbers strap to casing.
4. Position and secure coil in front of furnace discharge end.
5. Make sure coil is level for proper condensate drainage.
6. Using appropriate fasteners from duct type, connect supply-air duct to coil.

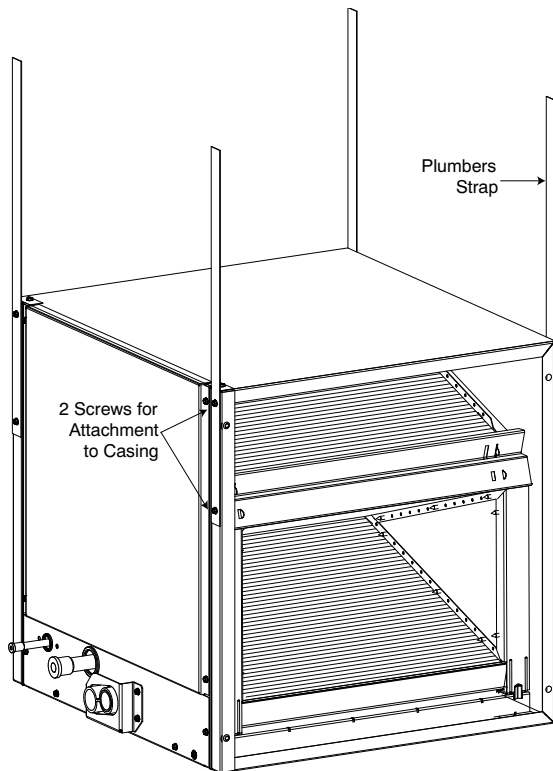

Fig. 7 – Suspension with Plumbers Strap

A05421

### REFRIGERANT LINE CONNECTIONS

#### ! WARNING

##### PERSONAL INJURY HAZARD

Failure to follow this warning could result in personal injury.

Wear eye protection.

Coil is factory charged with 15 psi nitrogen. The coil is under pressure and TXV screen is in place behind liquid line plug. **DO NOT** remove liquid line plug first; always remove the suction line plug first to depressurize the coil.

**NOTE:** Factory nitrogen charge may escape past rubber plugs during storage. This does not indicate a leaking coil nor warrant return of the coil.

Refrigerant lines must be configured per local building codes and the guidelines outlined in the OD units installation instructions.

Size and install refrigerant lines according to information provided with outdoor unit. Coil connection tube sizes are shown in Table 3. Route refrigerant lines to the coil in a manner that will not obstruct service access to the unit or removal of the filter.

Table 3 – Coil Connection Tube Size

MODEL NUMBER	COIL CONNECTION TUBE SIZE in (mm)	
	Liquid	Suction
CNPHP2417ALA	3/8 (10)	5/8 (16)
CNPHP3017ALA	3/8 (10)	3/4 (19)
CNPHP3617ALA	3/8 (10)	3/4 (19)
CNPHP4221ALA	3/8 (10)	7/8 (22)
CNPHP4321ALA	3/8 (10)	7/8 (22)
CNPHP4821ALA	3/8 (10)	7/8 (22)
CNPHP6024ALA	3/8 (10)	7/8 (22)
CNPHP6124ALA	3/8 (10)	7/8 (22)

**NOTE:** The filter dryer should be placed just before the indoor unit.

#### Connect Refrigerant Liquid and Suction Lines

For matched and mismatched systems, use line sizes recommended in outdoor unit Installation Instructions.

The coil can be connected to outdoor units using accessory refrigerant line sets or field-supplied lines of refrigerant grade.

See Table 3 for coil connection tube size.

#### ! CAUTION

##### UNIT OR PROPERTY DAMAGE HAZARD

Failure to follow this caution may result in property damage.

Take precautions to ensure aluminum tubes do not come in direct contact or allow for condensate run-off with a dissimilar metal. Dissimilar metals can cause galvanic corrosion and possible premature failure.

The coil can be connected to outdoor units using field-supplied tubing of refrigerant grade. Always evacuate tubing and reclaim refrigerant when making connections or flaring tubing. Leak check connections before insulating entire suction line.

See Table 3 for coil connection tube size.

#### ! CAUTION

##### UNIT DAMAGE HAZARD

Failure to follow this caution may result in product damage.

To avoid valve damage to the refrigerant control device while brazing, valves must be wrapped with a heat-sinking material such as a wet cloth.

1. Remove cabinet access door.
2. Remove rubber plugs, suction plug then liquid plug, from coil stubs using a pulling and twisting motion. Hold coil stubs steady to avoid bending or distorting.
3. Remove tubing plate with rubber grommets and slide plate with grommets onto the refrigerant lines (field line-set), away from braze joints.
4. Fit refrigerant lines into coil stubs. Wrap a heat sinking material such as a wet cloth behind braze joints.
5. Wrap TXV and nearby tubing with a heat-sinking material such as a wet cloth.
6. Use 1/2 psig Nitrogen purge in the suction and out the liquid line.
7. Braze using a Sil-Fos or Phos-copper alloy. Do not use soft solder.

8. After brazing, allow joints to cool. Carefully remove TXV bulb insulation and verify that the TXV bulb is securely fastened with hose clamp. Tighten screw a half-turn past hand tight with TXV bulb placed in the indentation with full contact with the vapor line tube. Re-wrap TXV bulb with insulation.
9. Leak check connections before insulating entire suction line.
10. Slide tubing plate with rubber grommets over joints. Position tubing at center of each grommet to ensure an air seal around the tube. Reinstall cabinet door.

**CONDENSATE DRAIN LINE CONNECTION**

**! CAUTION**

**PROPERTY DAMAGE HAZARD**  
 Failure to follow this caution may result in property damage. When installing over a finished ceiling and/or living area, install a field-fabricated secondary condensate pan under the entire unit.

The coil is designed to dispose of accumulated water through built-in condensate drain fittings. It is recommended that PVC fittings be used on the condensate pan. Do not over-tighten. Finger tighten plus 1-1/2 turns. Be sure to install plastic plug in unused condensate drain fitting. Two 3/4-in. female threaded pipe connections are provided in each coil condensate pan.

A trap is not necessary on the condensate line. Consult local codes for additional restrictions or precautions. If local codes require a trap then the following guidelines are suggested to assure proper drainage. Install a trap in condensate line of coil as close to the coil as possible. Make trap at least 3 in. (76 mm) deep and no higher than the bottom of unit condensate drain opening (Fig. 8). Pitch condensate line 1 in. (25.4 mm) for every 10 ft. of length to an open drain or sump. Make sure that the outlet of each trap is below its connection to condensate pan to prevent condensate from overflowing the drain pan. Prime all traps, test for leaks, and insulate traps and lines if located above a living area.

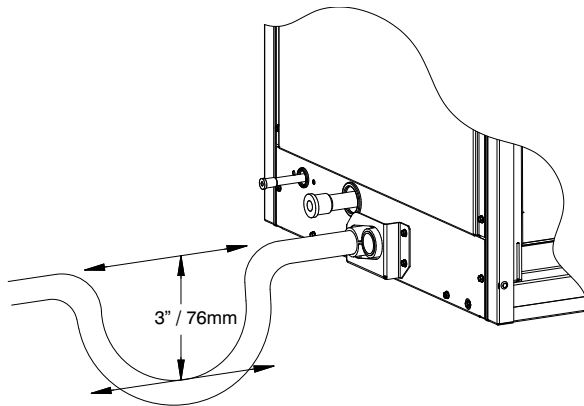

**Fig. 8 – Condensate Trap**

A08067

**NOTE:** If unit is located in or above a living space, where damage may result from condensate overflow, a field-supplied, external condensate pan should be installed underneath the entire unit, and a secondary condensate line (with appropriate trap) should be run from the unit into the pan. Any condensate in this external condensate pan should be drained to a noticeable place. As an alternative to using an external condensate pan, some localities may allow the running of a separate 3/4-in. (19 mm) condensate line (with appropriate trap) per local code to a place where the condensate will be noticeable. The owner of the

structure must be informed that when condensate flows from secondary drain or external condensate pan, the unit requires servicing or water damage will occur. To further protect against water damage, install a float switch to shut the unit off if the water in the secondary pan gets too high.

**NOTE:** To avoid drainage problems, test the primary drain line by slowly pouring water into the pan. Check piping for leaks and proper condensate drainage. Using the secondary drain as explained in the previous note provides further protection against overflow due to a clogged primary drain.

**NOTE:** In applications where return air humidity levels stay at 70% or above for a prolonged period of time, condensation can form on the bottom of pan and drip.

**WASTE LINE CONNECTION**

**! WARNING**

**EXPLOSION HAZARD**  
 Failure to follow this warning could result in personal injury or death. Provide trap with air gap in drain line when connecting to waste (sewer) line.

If the condensate line is to be connected to a waste (sewer) line, an open trap must be installed ahead of the waste line to prevent escape of sewer gases (Fig. 9).

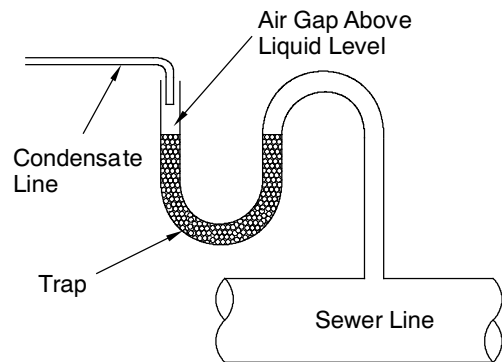

**Fig. 9 – Condensate Drain to Waste Line**

A10216

**CARE AND MAINTENANCE**

To continue high performance and minimize possible equipment failure, it is essential that periodic maintenance be performed on this equipment. Consult your local dealer as to the proper frequency of maintenance, but it should be done at least annually.

The ability to properly perform maintenance on this equipment requires certain mechanical skills and tools. If you do not possess these, contact your dealer for maintenance. The only consumer service recommended or required is filter replacement or cleaning on a monthly basis.

**! CAUTION**

**ENVIRONMENTAL HAZARD**  
 Failure to follow this caution may result in environmental damage. Remove and recycle all components or materials (i.e., oil, refrigerant, etc.) before unit final disposal.