

**MODEL 226C
PREFERRED™ SERIES HEAT PUMP
WITH PURON® REFRIGERANT
1-1/2 TO 5 NOMINAL TONS**



Product Data



Preferred[™]
SERIES

Bryant's 226C heat pump provides a collection of features unmatched by any other family of equipment. The 226C has been designed utilizing Bryant's non-ozone depleting Puron refrigerant. This product has been designed and manufactured to meet Energy Star® criteria for energy efficiency when matched with appropriate coil components. Refer to the combination ratings in the AHRI Directory for system combinations that meet Energy Star® guidelines.

NOTE: Ratings contained in this document are subject to change at any time. Always refer to the AHRI directory (www.ahridirectory.org) for the most up-to-date ratings information.

INDUSTRY LEADING FEATURES / BENEFITS

Energy Efficiency

- 14.0 - 16.0 SEER/11.5 - 13.0 EER/8.2 - 9.0 HSPF
- Microtube Technology™ refrigeration system
- Indoor air quality accessories available

Sound

- Sound level as low as 67 dBA

Comfort

- System supports Thermidstat™ or standard thermostat controls

Reliability

- Non-ozone depleting Puron® refrigerant
- Front-seating service valves
- Scroll compressor
- Internal pressure relief valve
- Internal thermal overload
- High pressure switch
- Loss of charge switch
- Filter drier
- Balanced refrigeration system for maximum reliability

Durability

WeatherArmor Ultra™ protection package:

- Solid, Durable sheet metal construction
- Steel louver coil guard
- Baked-on, complete outer coverage, powder paint

Applications

- Long-line - up to 250 feet (76.2 m) total equivalent length, up to 200 feet (60.96 m) condenser above evaporator, or up to 80 ft. (24.38 m) evaporator above condenser (See Longline Guide for more information.)
- Low ambient cooling (down to -10°F / -23°C) with approved low ambient accessory kits.

MODEL NUMBER NOMENCLATURE

1	2	3	4	5	6	7	8	9	10	11	12	14
N	N	N	A	A/N	N	N	N	N	A/N	A/N	N	A
2	2	6	C	N	A	0	3	6	0	0	0	A
Product Family 2=HP	Tier 2= Preferred Series	SEER 6=16 SEER	Major Series C=Puron	Voltage N=208/230-1 P=208/230-3	Variations A = Standard	Cooling Capacity			Open 0=Not Defined	Open 0=Not Defined	Open 0=Not Defined	Series A = Original Series



Use of the AHRI Certified TM Mark indicates a manufacturer's participation in the program. For verification of certification for individual products, go to www.ahridirectory.org.



ISO 9001
QMI-SAI Global



This product has been designed and manufactured to meet Energy Star® criteria for energy efficiency when matched with appropriate coil components. However, proper refrigerant charge and proper air flow are critical to achieve rated capacity and efficiency. Installation of this product should follow all manufacturing refrigerant charging and air flow instructions. **Failure to confirm proper charge and air flow may reduce energy efficiency and shorten equipment life.**

STANDARD FEATURES

FEATURES	Unit Size – Series (voltage)									
	18-A (N)	24-A (N)	30-A (N)	36-A (N)	36-A (P)	42-A (N)	48-A (N)	48-A (P)	60-A (N)	60-A (P)
Puron Refrigerant	X	X	X	X	X	X	X	X	X	X
Maximum SEER Rating*	16.0	16.0	16.0	16.0	15.4	16.0	16.0	15.4	16.0	15.4
Scroll Compressor	X	X	X	X	X	X	X	X	X	X
Crankcase Heater				X	X			X	X	X
Low Ambient Cooling Capability with Approved Kits	X	X	X	X	X	X	X	X	X	X
Louvered Coil Guard	X	X	X	X	X	X	X	X	X	X
Sound Shield	X	X	X	X	X	X	X	X	X	X
Field Installed Filter Drier	X	X	X	X	X	X	X	X	X	X
Front Seating Service Valves	X	X	X	X	X	X	X	X	X	X
Internal Pressure Relief Valve	X	X	X	X	X	X	X	X	X	X
Long Line capability	X	X	X	X	X	X	X	X	X	X
Loss of Charge Switch	X	X	X	X	X	X	X	X	X	X
High Pressure Switch	X	X	X	X	X	X	X	X	X	X

* = With approved combinations
X = Standard

PHYSICAL DATA

UNIT SIZE SERIES	18	24	30	36	42	48	60
Compressor Type	Scroll						
REFRIGERANT	Puron® (R-410A)						
Charge lb (kg)	7.00 (3.18)	7.60 (3.45)	9.75 (4.42)	11.20 (5.08)	9.92 (4.50)	9.87 (4.48)	13.00 (5.90)
Indoor Control	TXV (Puron Hard Shutoff)						
Outdoor Heating Piston #	TXV	TXV	TXV	55	59	TXV	65
COND FAN	Propeller Type, Direct Drive						
Air Discharge	Vertical						
Air Qty (CFM)	2233	3223	3223	3223	3770	4046	4400
Motor HP	1/12	1/12	1/12	1/12	1/3	1/4	1/3
Motor RPM	810	810	810	810	700	810	767
COND COIL							
Face Area (Sq ft)	19.30	20.10	20.10	20.10	20.10	20.10	35.47
Fins per In.	20	20	20	20	20	20	20
Rows	1	1	2	2	2	2	2
Circuits	5	5	6	8	8	8	12
VALVE CONNECT. (In. ID)							
Vapor	5/8		3/4		7/8		1-1/8
Liquid	3/8"						
REFRIGERANT TUBES* (In. OD)							
Rated Vapor (0-80 Ft Tube Length)	5/8		3/4		7/8		1-1/8
Max Liquid Line	3/8						

* Units are rated with 25 ft (7.6 m) of lineset length. See Vapor Line Sizing and Cooling Capacity Loss table when using other sizes and lengths of lineset.

Note: See unit Installation Instruction for proper installation.

VAPOR LINE SIZING AND COOLING CAPACITY LOSS

Acceptable vapor line diameters provide adequate oil return to the compressor while avoiding excessive capacity loss. The suction line diameters shown in the chart below are acceptable for HP systems with Puron refrigerant:

Vapor Line Sizing and Cooling Capacity Losses - Puron® Refrigerant 1- Stage Heat Pump Applications

Unit Nominal Size (Btuh)	Maximum Liquid Line Diameters (In. OD)	Acceptable Vapor Line Diameters (In. OD)	Cooling Capacity Loss (%) Total Equivalent Line Length (ft)											
			Standard Application			Long Line Application Requires Accessories								
			25 (7.62)	50 (15.2)	80 (24.4)	80+ (24.4+)	100 (30.48)	125 (38.10)	150 (45.72)	175 (53.34)	200 (60.96)	225 (68.58)	250 (76.20)	
18000 1-Stage HP	3/8	1/2	1	2	3	3	4	6	7	8	9	10	12	
		5/8	0	0	1	1	1	1	2	2	3	3	3	
24000 1-Stage HP	3/8	5/8	0	1	1	1	2	3	3	4	4	5	6	
		3/4	0	0	0	0	0	1	1	1	1	1	2	
30000 1-Stage HP	3/8	5/8	1	2	3	3	3	4	5	6	7	8	9	
		3/4	0	0	1	1	1	1	2	2	2	3	3	
		7/8	0	0	0	0	0	1	1	1	1	1	1	
36000 1-Stage HP	3/8	5/8	1	2	4	4	5	6	7	9	10	11	13	
		3/4	0	0	1	1	1	2	2	3	3	4	4	
		7/8	0	0	0	0	0	1	1	1	1	2	2	
42000 1-Stage HP	3/8	3/4	0	1	2	2	2	3	4	4	5	6	6	
		7/8	0	0	1	1	1	1	2	2	2	3	3	
48000 1-Stage HP	3/8	3/4	0	1	2	2	3	4	5	5	6	7	8	
		7/8	0	0	1	1	1	2	2	2	3	3	4	
60000 1-Stage HP	3/8	3/4	1	2	4	4	5	6	7	9	10	11	12	
		7/8	0	1	2	2	2	3	4	4	5	5	6	
		1 1/8	0	0	0	0	1	1	1	1	1	1	2	

Standard Length = 80 ft. (24.4 m) or less total equivalent length

Applications in this area are long line. Accessories are required as shown recommended on Long Line Application Guidelines

Applications in this area may have height restrictions that limit allowable total equivalent length, when outdoor unit is below indoor unit. See Long Line Application Guidelines

REFRIGERANT PIPING LENGTH LIMITATIONS

Maximum Line Lengths:

The maximum allowable total equivalent length for heat pumps varies depending on the vertical separation. See the tables below for allowable lengths depending on whether the outdoor unit is on the same level, above or below the indoor unit.

Maximum Line Lengths for Heat Pump Applications

	MAXIMUM ACTUAL LENGTH ft (m)	MAXIMUM EQUIVALENT LENGTH† ft (m)	MAXIMUM VERTICAL SEPARATION ft (m)
Units on equal level	200 (61)	250 (76.2)	N/A
Outdoor unit ABOVE indoor unit	200 (61)	250 (76.2)	200 (61)
Outdoor unit BELOW indoor unit	See Table 'Maximum Total Equivalent Length: Outdoor Unit BELOW Indoor Unit'		

† Total equivalent length accounts for losses due to elbows or fitting. See the Long Line Guideline for details.

Maximum Total Equivalent Length† - Outdoor Unit BELOW Indoor Unit

Size	Liquid Line Diameter w/ TXV	HP with Puron® Refrigerant – Maximum Total Equivalent Length† Vertical Separation ft (m) Outdoor unit BELOW indoor unit;						
		0–20 (0 – 6.1)	21–30 (6.4 – 9.1)	31–40 (9.4 – 12.2)	41–50 (12.5 – 15.2)	51–60 (15.5 – 18.3)	61–70 (18.6 – 21.3)	71–80 (21.6 – 24.4)
18000 HP with Puron	3/8	250*	250*	250*	250*	250*	250*	250*
24000 HP with Puron	3/8	250*	250*	250*	250*	250*	250*	250*
30000 HP with Puron	3/8	250*	250*	250*	250*	250*	250*	250*
36000 HP with Puron	3/8	250*	250*	250*	250*	250*	250*	250*
42000 HP with Puron	3/8	250*	250*	250*	250*	250*	250*	150
48000 HP with Puron	3/8	250*	250*	250*	250*	230	160	–
60000 HP with Puron	3/8	250*	225*	190	150	110	–	–

* Maximum actual length not to exceed 200 ft (61 m)

† Total equivalent length accounts for losses due to elbows or fitting. See the Long Line Guideline for details.

– = outside acceptable range

LONG LINE APPLICATIONS

An application is considered Long Line when the refrigerant level in the system requires the use of accessories to maintain acceptable refrigerant management for systems reliability. Defining a system as long line depends on the liquid line diameter, actual length of the tubing, and vertical separation between the indoor and outdoor units.

For Heat Pump systems, the chart below shows when an application is considered Long Line. Beyond these lengths, long line accessories are required:

HP WITH PURON® REFRIGERANT LONG LINE DESCRIPTION ft (m)

Beyond these lengths, long line accessories are required

Liquid Line Size	Units On Same Level	Outdoor Below Indoor	Outdoor Above Indoor
3/8	80 (24.4)	20 (6.1) vertical or 80 (24.4) total	80 (24.4)

Note: See Long Line Guideline for details

ACCESSORY THERMOSTATS

Part Number	Description	Capabilities			Heat Stages	Cool Stages
		Gas	Electric	Heat Pump		
T6-WEM01	Housewise™ Wi-Fi Programmable Relative Humidity Thermostat	√	√	√	4	2
T6-PRH01-A	Programmable Relative Humidity Thermostat	√	√	√	3	2
T6-PHP01	Programmable Thermostat (HP or AC)		√	√	3	2
T6-NRH01-A	Non-Programmable Relative Humidity Thermostat	√	√	√	3	2
T6-NHP01	Non-Programmable Thermostat (HP or AC)		√	√	3	2
T2-WHS01	Wi-Fi® Programmable	√	√	√	3	2
T2-PHP01	5-2 Day Programmable Thermostat		√	√	3	2
T2-NHP01	Non-Programmable Thermostat (HP or AC)		√	√	3	2
T2SNHP01	Non-Programmable Thermostat (HP or AC)		√	√	2	1

Thermostat Accessories		
Part Number	Description	Used With
T6-EXP01-A	Exp® Computer Programming Accessory	T6-P thermostats
TSTATXXCNV10	Thermostat Conversion Kit (4 to 5 wire) – 10 pack	All Bryant® branded thermostats
TX-LBP01	Large Decorative Backplate	T6-Pxx, T6-Nxx, and T2-Pxx
TX-MBP01	Medium Decorative Backplate	T2-Nxx
TSTATXXSEN01-B*	Outdoor Air Temperature Sensor	All T6- thermostats

ACCESSORIES

Kit Number	Description	18	24	30	36	42	48	60
KHAFM0201AAA*	PSC FAN MOTOR KIT					X		X
KAACH1601AAA	CRKC HTR KIT					X	X	S
KAACH1701AAA	CRKC HTR KIT	X	X	X	S			
KAACS0201PTC	KIT PTC	X	X	X	X	X	X	X
KAATD0101TDR	TIME DELAY KIT	X	X	X	X	X	X	X
KHAIR0201AAA	ISLN RELAY KIT	X	X	X	X	X	X	X
KHALS0401LLS	SOL VALVE KIT	X	X	X	X	X	X	X
KHASS0606MPK†	SNOW STAND KIT	X	X	X	X	X	X	X
KSACY0101AAA	CYCLE PROTR KIT	X	X	X	X	X	X	X
KSAFT0101AAA	FRZ THERM KIT	X	X	X	X	X	X	X
KSAHS1501AAA	HARD START KIT				X			X
KSAHS2401AAA	HARD START KIT	X	X	X		X	X	
KSALA0301410	LOW AMBIENT KIT	X	X	X	X	X	X	X
KSALA0601AAA	MOTORMASTER KIT	X	X	X	X	X	X	X
KSASF0201AAA	SPRT FEET KIT	X	X	X	X	X	X	X
KSATX0201PUR	TXV KIT; Copper	X	X	X				
KSATX0301PUR	TXV KIT; Copper				X	X		
KSATX0401PUR	TXV KIT; Copper						X	X
KSBTX0201PUR	TXV KIT; Aluminum	X	X	X				
KSBTX0301PUR	TXV KIT; Aluminum				X	X		
KSBTX0401PUR	TXV KIT; Aluminum						X	X

S =Standard

x = Accessory

* Required for use with low ambient or motor master kits. Efficiency will not be met with this accessory installed.

† Available from RCD

ACCESSORY USAGE GUIDELINE

Table 1 – Accessory Usage

Accessory	REQUIRED FOR LOW-AMBIENT COOLING APPLICATIONS (Below 55°F / 12.8°C)	REQUIRED FOR LONG LINE APPLICATIONS*	REQUIRED FOR SEA COAST APPLICATIONS (Within 2 miles / 3.22 km)
Accumulator	Standard	Standard	Standard
Ball Bearing Fan Motor	Standard†	No	No
Compressor Start Assist Capacitor and Relay	Yes	Yes	No
Crankcase Heater	Yes	Yes	No
Evaporator Freeze Thermostat	Yes	No	No
Hard Shutoff TXV	Yes	Yes	Yes
Isolation Relay	Yes	No	No
Liquid Line Solenoid Valve	No	See Long-Line Application Guideline	No
Motor Master® Control or Low Ambient Switch	Yes‡	No	No
Support Feet	Recommended	No	Recommended
Winter Start Control**	Yes**	No	No

* For tubing line sets between 80 and 200 ft. (24.38 and 60.96 m) and/or 20 ft. (6.09 m) vertical differential, refer to Residential Piping and Longline Guideline.

† Required for Low-Ambient Controller (full modulation feature) MotorMaster® Control. Standard on all models except sizes 042 and 060.

‡ In units equipped with ECM OD motor, motor needs to be replaced per unit accessory guide to work properly. This motor kit comes with a new defrost board that also needs to be installed. Unit will not meet AHRI rated efficiency once motor and control board are replaced to use this accessory.

**0Required if Low Pressure Switch is factory or field installed.

Accessory Description and Usage (Listed Alphabetically)

1. Ball Bearing Fan Motor

A fan motor with ball bearings which permits speed reduction while maintaining bearing lubrication.

Usage Guideline:

Required on all units when using MotorMaster®

2. Compressor Start Assist - Capacitor and Relay

Start capacitor and relay gives a “hard” boost to compressor motor at each start up.

Usage Guideline:

Required for 2-stage non-communicating units in the following applications:

Long line

Low ambient cooling

Suggested for all compressors in areas with a history of low voltage problems.

3. Crankcase Heater

An electric resistance heater which mounts to the base of the compressor to keep the lubricant warm during off cycles. Improves compressor lubrication on restart and minimizes the chance of liquid slugging.

Usage Guideline:

Required in low ambient cooling applications.

Required in long line applications.

Suggested in all commercial applications.

4. Evaporator Freeze Thermostat

An SPST temperature-actuated switch that stops unit operation when evaporator reaches freeze-up conditions.

Usage Guideline:

Required when low ambient kit has been added.

5. Isolation Relay

An SPDT relay which switches the low ambient controller out of the outdoor fan motor circuit when the heat pump switches to heating mode.

Usage Guideline:

Required in all heat pumps where low ambient kit has been added.

6. Low-Ambient Pressure Switch

A long life pressure switch which is mounted to outdoor unit service valve. It is designed to cycle the outdoor fan motor in order to maintain head pressure within normal operating limits. The control will maintain working head pressure at low-ambient temperatures down to 0°F (-17.8°C) when properly installed.

Usage Guideline:

A Low-Ambient Pressure Switch must be used when cooling operation is used at outdoor temperatures below 55°F (12.8°C).

7. Liquid-Line Solenoid Valve (LLS)

An electrically operated shutoff valve which stops and starts refrigerant liquid flow in response to compressor operation. It is to be installed at the outdoor unit to control refrigerant off cycle migration in the heating mode.

Usage Guideline:

8. MotorMaster® Low-Ambient Controller

Fan-speed control device activated by a temperature sensor, designed to control condenser fan motor speed in response to the saturated, condensing temperature during operation in cooling mode only. For outdoor temperatures down to -10°F (-23°C), it maintains condensing temperature at 100°F ± 10°F (37.8°C ± 6.5°C)

Usage Guideline:

A MotorMaster Low-Ambient Controller or Low-Ambient Pressure Switch must be used when cooling operation is used at outdoor temperatures below 55°F (12.8°C).

An LLS is required in all long line heat pump applications to control refrigerant off cycle migration in the heating mode. See Long Line Guideline.

9. Snow Stand

Coated wire rack which supports unit 18 in. (457.2 mm) above mounting pad to allow for drainage from unit base.

Usage Guideline:

Suggested in the following applications:

Heat pump installations in heavy snowfall areas.

Heat pump installations in snow drift locations.

Heat pump installations in areas of prolonged subfreezing temperatures.

All commercial installations.

10. Thermostatic Expansion Valve (TXV) Bi-Flow

A modulating flow-control valve which meters refrigerant liquid flow rate into the evaporator in response to the superheat of the refrigerant gas leaving the evaporator.

Usage Guideline:

Accessory required to meet AHRI rating and system reliability, where indoor not equipped.

Required in all heat pump applications designed with Puron refrigerant.

ELECTRICAL DATA

UNIT SIZE – SERIES (VOLTAGE)	V/PH	OPER VOLTS*		COMPR		FAN	MCA	MAX FUSE† or CKT BRK AMPS
		MAX	MIN	LRA	RLA	FLA		
18–A (N)	208/230–1	253	197	56.3	10.5	0.50	13.6	20
24–A (N)				62.9	11.9	0.60	15.5	25
30–A (N)				72.5	15.4	0.60	19.9	30
36–A (N)				75.0	16.8	0.60	21.6	35
42–A (N)				123.9	20.0	2.80	27.8	40
48–A (N)				130.0	24.4	1.30	31.8	45
60–A (N)	208/230–3	253	187	152.5	24.9	2.80	33.9	50
36–A (P)				73.0	11.5	0.50	14.9	25
48–A (P)				83.1	13.7	1.20	18.3	30
60–A (P)				110.0	16.0	2.80	22.8	35

* Permissible limits of the voltage range at which the unit will operate satisfactorily

† Time–Delay fuse.

FLA – Full Load Amps

LRA – Locked Rotor Amps

MCA – Minimum Circuit Amps

RLA – Rated Load Amps

NOTE: Control circuit is 24–V on all units and requires external power source. Copper wire must be used from service disconnect to unit.

All motors/compressors contain internal overload protection.

Complies with 2010 requirements of ASHRAE Standards 90.1

SOUND DATA

Single Phase A-Weighted Sound Power (dBA)								
UNIT SIZE – SERIES (VOLTAGE)	STANDARD RATING	TYPICAL OCTAVE BAND SPECTRUM (without tone adjustment)						
		125	250	500	1000	2000	4000	8000
18–A (N)	68	66.2	63.8	64.1	64.6	59.9	57.7	53.6
24–A (N)	72	63.4	63.3	63.3	70.4	64.5	59.3	55.5
30–A (N)	72	65.0	65.0	66.0	69.0	65.0	62.0	59.0
36–A (N)	72	67.7	66.8	68.1	69.9	62.8	60.3	55.2
42–A (N)	68	63.9	64.1	65.0	64.9	58.2	57.3	56.7
48–A (N)	73	67.5	67.8	70.1	70.6	63.1	58.5	53.3
60–A (N)	70	61.7	65.6	68.1	65.8	59.8	58.4	56.1

Single Phase A-Weighted Sound Power (dBA) with Accessory Sound Shield								
UNIT SIZE – SERIES (VOLTAGE)	STANDARD RATING	TYPICAL OCTAVE BAND SPECTRUM (without tone adjustment)						
		125	250	500	1000	2000	4000	8000
18–A (N)	67	66.2	63.9	63.8	62.3	58.4	56.4	50.3
24–A (N)	71	65.0	63.7	63.4	68.5	64.7	58.7	52.8
30–A (N)	70	67.1	66.3	66.6	66.9	62.9	58.1	53.0
36–A (N)	71	68.2	66.4	67.5	68.4	59.6	58.2	52.4
42–A (N)	68	63.0	64.2	66.3	63.5	57.1	55.4	55.8
48–A (N)	71	68.4	67.7	69.7	67.6	59.4	56.4	50.0
60–A (N)	69	63.7	65.4	67.3	64.9	58.3	56.2	51.9

Three Phase A-Weighted Sound Power (dBA) [Includes Sound Shield]								
UNIT SIZE – SERIES (VOLTAGE)	STANDARD RATING	TYPICAL OCTAVE BAND SPECTRUM (without tone adjustment)						
		125	250	500	1000	2000	4000	8000
36–A (P)	72	43.3	50.6	59.5	65.7	57.0	53.6	45.6
48–A (P)	72	45.9	55.0	60.6	62.2	57.4	51.9	48.8
60–A (P)	72	45.2	51.2	62.1	62.4	60.1	54.5	49.4

NOTE: Tested in compliance with AHRI 270–2008 but not listed with AHRI.

CHARGING SUBCOOLING (TXV-TYPE EXPANSION DEVICE)

UNIT SIZE – VOLTAGE, SERIES (VOLTAGE)	REQUIRED SUBCOOLING °F (°C)
18–A (N)	8 (4.44)
24–A (N)	7 (3.89)
30–A (N)	7 (3.89)
36–A (N)	10 (5.56)
42–A (N)	9 (5.00)
48–A (N)	9 (5.00)
60–A (N)	7 (3.89)
36–A (P)	10 (5.56)
48–A (P)	9 (5.00)
60–A (P)	7 (3.89)

DIMENSIONS

UNIT	SERIES	ELECTRICAL CHARACTERISTICS					A		B		C		D		E		F		G		H		I		J		K		OPERATING WEIGHT		SHIPPING WEIGHT		SHIPPING LENGTH / WIDTH (Sq.)		SHIPPING HEIGHT											
		Y	N	N	N	N	INCH	MM	INCH	MM	INCH	MM	INCH	MM	INCH	MM	INCH	MM	INCH	MM	INCH	MM	INCH	MM	INCH	MM	INCH	MM	Lbs	Kgs	Lbs	Kgs	INCH	MM	INCH	MM										
226CNA018000GAAA	A	Y	N	N	N	31	3/16	792.5	35	1/2	901.4	5/8	15.9	6	9/16	166.1	24	11/16	626.3	9	1/8	231.3	1	1/8	28.2	3	13/16	97.4	15	3/4	400.1	16	406.4	16	1/4	412.8	181	82.1	213	96.6	33	5/16	846.6	40	1015.8	
226CNA024000GAAA	A	Y	N	N	N	35	889.0	32	1/16	815.1	5/8	15.9	6	9/16	166.1	28	7/16	722.8	9	1/8	231.3	1	1/8	28.2	3	13/16	97.4	17	1/2	444.5	17	7/8	454.0	15	5/8	396.9	192	87.1	230	104.3	37	1/8	943.1	36	5/8	929.5
226CNA030000GAAA	A	Y	N	N	N	35	889.0	32	1/16	815.1	3/4	19.1	6	9/16	166.1	28	7/16	722.8	9	1/8	231.3	1	1/8	28.2	3	13/16	97.4	17	1/4	438.2	16	7/8	428.6	15	3/4	400.1	227	103.0	265	120.2	37	1/8	943.1	36	5/8	929.5
226CNA036000BAAA	A	Y	N	N	N	35	889.0	32	1/16	815.1	3/4	19.1	6	9/16	166.1	28	7/16	722.8	9	1/8	231.3	1	1/8	28.2	3	13/16	97.4	17	3/8	441.3	17	1/2	444.5	13	3/4	349.3	235	106.6	273	123.8	37	1/8	943.1	36	5/8	929.5
226CNA042000GAAA	A	Y	N	N	N	35	889.0	32	1/16	815.1	7/8	22.2	6	9/16	166.1	28	7/16	722.8	9	1/8	231.3	1	1/8	28.2	3	13/16	97.4	16	1/4	412.8	17	7/8	454.0	15	7/8	403.2	253	114.8	291	132.0	37	1/8	943.1	36	5/8	929.5
226CNA048000GAAA	A	Y	N	N	N	35	889.0	32	1/16	815.1	7/8	22.2	6	9/16	166.1	28	7/16	722.8	9	1/8	231.3	1	1/8	28.2	3	13/16	97.4	16	1/8	409.6	18	457.2	14	7/8	377.8	258	117.0	296	134.3	37	1/8	943.1	36	5/8	929.5	
226CNA060000GAAA	A	Y	N	N	N	35	889.0	45	11/16	1160.5	7/8	22.2	6	9/16	166.1	28	7/16	722.8	9	1/8	231.3	1	1/8	28.2	3	13/16	97.4	17	7/8	454.0	16	1/4	412.8	19	482.6	316	143.3	362	164.2	37	1/8	943.1	50	3/16	1274.9	
226CPA036000GAAA	A	N	Y	N	N	35	889.0	32	1/16	815.1	3/4	19.1	6	9/16	166.1	28	7/16	722.8	9	1/8	231.3	1	1/8	28.2	3	13/16	97.4	17	3/8	441.3	17	1/2	444.5	13	3/4	349.3	235	106.6	273	123.8	37	1/8	943.1	36	5/8	929.5
226CPA048000GAAA	A	N	Y	N	N	35	889.0	32	1/16	815.1	7/8	22.2	6	9/16	166.1	28	7/16	722.8	9	1/8	231.3	1	1/8	28.2	3	13/16	97.4	16	1/8	409.6	18	457.2	14	7/8	377.8	258	117.0	296	134.3	37	1/8	943.1	36	5/8	929.5	
226CPA060000GAAA	A	N	Y	N	N	35	889.0	45	11/16	1160.5	7/8	22.2	6	9/16	166.1	28	7/16	722.8	9	1/8	231.3	1	1/8	28.2	3	13/16	97.4	17	7/8	454.0	16	1/4	412.8	19	482.6	316	143.3	362	164.2	37	1/8	943.1	50	3/16	1274.9	

205-230-1-60	Y=YES N=NO
209/230-3-60	
460-3-60	
575-3-60	

NOTES:

1. CENTER OF GRAVITY 

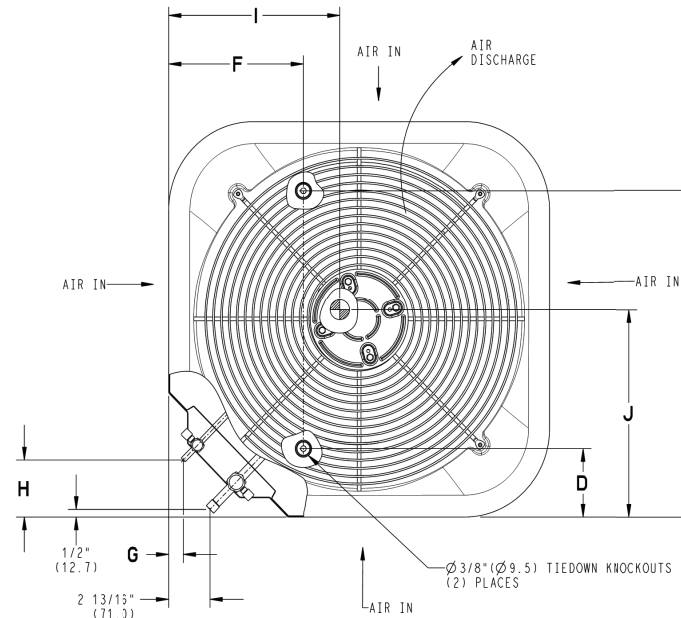
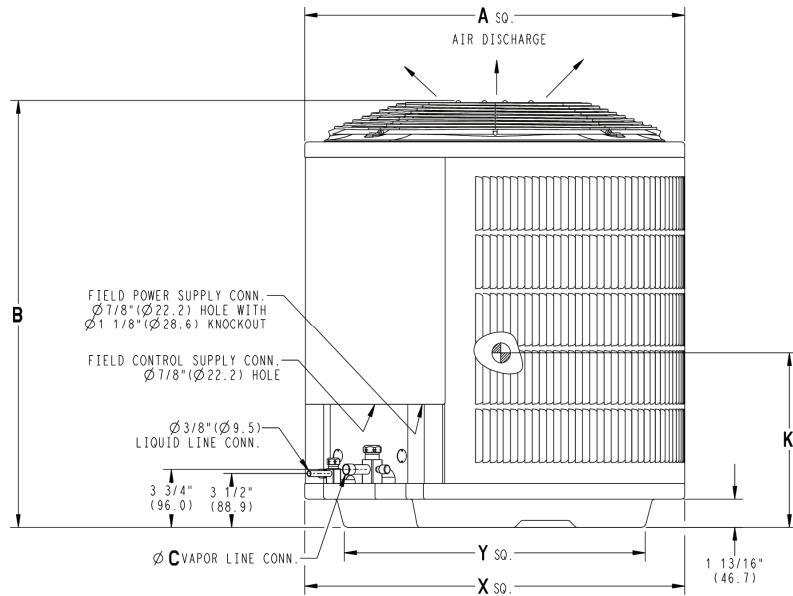

UNIT SIZE	"X"		"Y"			
	MINIMUM GROUND MOUNTING PAD APPLICATION DIMENSIONS		MINIMUM ROOF-TOP MOUNTING PAD APPLICATION DIMENSIONS			
	23	1/8	587.3	17	7/8	454.6
	25	3/4	654.0	20	7/16	518.5
18	31	3/16	792.5	22	15/16	583.2
24,30,36,42,48,60	35		889.0	26	3/4	679.7

NOTE: ALL DIMENSIONS IN INCH (MM)

U.S. ECCN: Not Subject to Regulation (N.S.R.)

CLEARANCES

Clearances (various examples)

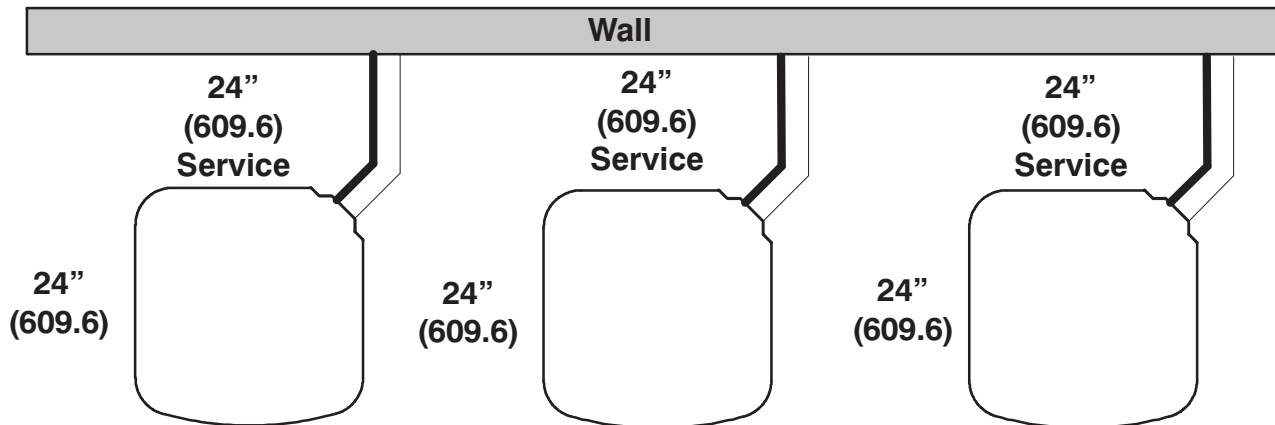
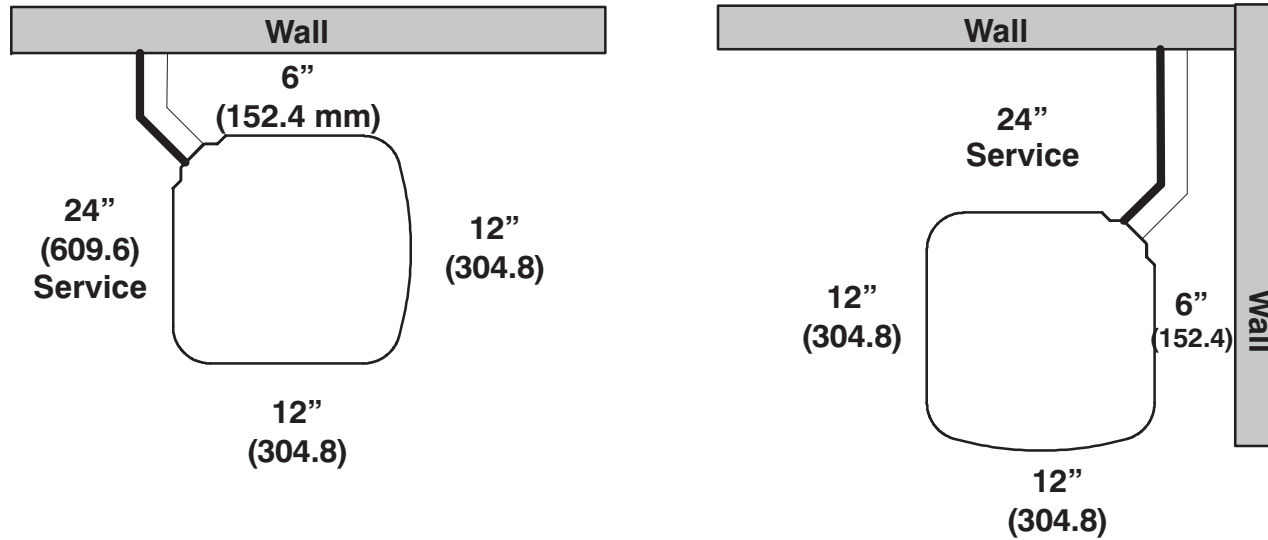

Note: Numbers in () = mm

IMPORTANT: When installing multiple units in an alcove, roof well, or partially enclosed area, ensure there is adequate ventilation to prevent re-circulation of discharge air.

226CAN BALANCE POINT WORKSHEET

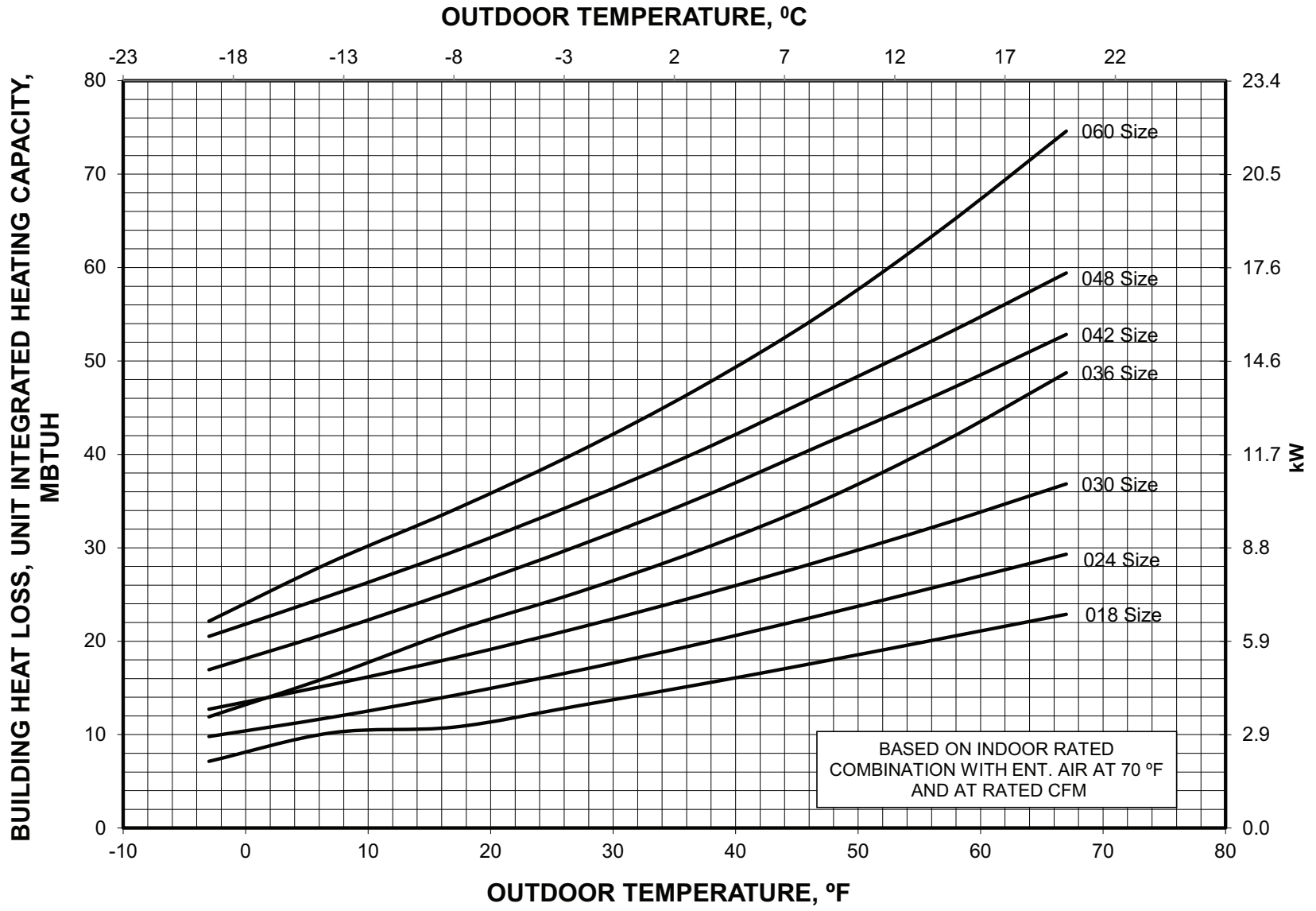

TESTED AHRI COMBINATION RATINGS*

NOTE: Ratings contained in this document are subject to change at any time.

For AHRI ratings certificates, please refer to the AHRI directory www.ahridirectory.org

Additional ratings and system combinations can be accessed via the Bryant database at: www.MyBryantRatings.com

For performance data at specific application &/or design conditions with various indoor unit combinations, the equipment performance calculator can be accessed at : <http://rpmobbry.wrightsoft.com/>

COMBINATION RATINGS

Model Number – Series	Indoor Coil Model Number	Furnace Model Number	Cooling Capacity	EER	SEER	High Temp		HSPF	Low Temp	
						E Capacity 47°F (8°C)	E COP		H Capacity 17°F (-8°C)	H COP
226CNA018-A	FX4DNF019L		18000	13	16	17800	3.92	8.5	10800	2.60
226CNA024-A	FX4DNF025L		23000	13	16	22800	3.90	8.5	14200	2.60
226CNA030-A	FX4DN(B,F)037L		29200	13	16	28600	3.72	9.0	17400	2.56
226CNA036-A	FX4DN(B,F)049L		35000	13	16	35000	4.16	8.5	20800	2.86
226CNA042-A	FX4DN(B,F)049L		40500	13	16	41000	3.94	8.5	25400	2.82
226CNA048-A	FX4DN(B,F)061L		48000	13	16	46500	3.84	9.0	29600	2.74
226CNA060-A	FX4DN(B,F)061L		55000	13	16	55000	3.82	8.5	33600	2.82
226CPA036-A	FX4DN(B,F)049L		34400	12.5	15.4	34400	4.16	8.5	21200	2.90
226CPA048-A	FX4DN(B,F)061L		47500	12.5	15.4	45500	3.84	8.5	29200	2.72
226CPA060-A	FX4DN(B,F)061L		56000	12.5	15.4	55000	3.84	8.5	35200	2.90

* AHRI = Air Conditioning, Heating & Refrigeration Institute

Ratings are net values reflecting the effects of circulating fan heat. Supplemental electric heat is not included. Ratings are based on:

Cooling Standard: 80°F (27°C) db 67°F (19°C) wb indoor entering air temperature and 95°F (35°C) db air entering outdoor unit.

High-Temp Heating Standard: 70°F (21°C) db indoor entering air temperature and 47°F (8°C) db 43°F (6°C) wb air entering outdoor unit.

Low-Temp Heating Standard: 70°F (21°C) db indoor entering air temperature and 17°F (-8°C) db 15°F (-9°C) wb air entering outdoor unit.

COP — Coefficient of Performance

EER — Energy Efficiency Ratio

HSPF — Heating Seasonal Performance Factor

SEER — Seasonal Energy Efficiency Ratio

DETAILED COOLING CAPACITIES#

EVAPORATOR AIR		CONDENSER ENTERING AIR TEMPERATURES ° F (° C)																	
CFM	EWB ° F (° C)	75 (23.9)			85 (29.4)			95 (35)			105 (40.6)			115 (46.1)			125 (51.7)		
		Capacity MBtu/h†		Total System KW**	Capacity MBtu/h†		Total System KW**	Capacity MBtu/h†		Total System KW**	Capacity MBtu/h†		Total System KW**	Capacity MBtu/h†		Total System KW**	Capacity MBtu/h†		Total System KW**
		Total	Sens‡		Total†	Sens‡		Total†	Sens‡		Total†	Sens‡		Total†	Sens‡		Total†	Sens‡	
226CNA018—A Outdoor Section With FX4DNF019L Indoor Section																			
545	72 (22.2)	21.64	11.38	0.99	20.62	10.99	1.17	19.56	10.60	1.37	18.43	10.19	1.60	17.23	9.75	1.87	15.94	9.29	2.19
	67 (19.4)	19.65	13.99	1.00	18.73	13.61	1.18	17.76	13.21	1.38	16.74	12.79	1.61	15.65	12.35	1.88	14.49	11.89	2.20
	63 (17.2)††	18.21	13.45	1.01	17.36	13.07	1.18	16.46	12.67	1.39	15.51	12.26	1.62	14.50	11.81	1.89	13.42	11.35	2.21
	62 (16.7)	17.90	16.53	1.01	17.08	16.13	1.18	16.22	15.71	1.39	15.34	15.19	1.62	14.47	14.47	1.89	13.59	13.59	2.21
	57 (13.9)	17.36	17.36	1.01	16.70	16.70	1.19	16.01	16.01	1.39	15.26	15.26	1.62	14.45	14.45	1.89	13.57	13.57	2.21
600	72 (22.2)	21.94	11.80	0.99	20.90	11.42	1.17	19.80	11.02	1.38	18.65	10.60	1.61	17.41	10.16	1.88	16.09	9.69	2.20
	67 (19.4)	19.95	14.67	1.00	19.00	14.28	1.18	18.00	13.87	1.38	16.95	13.45	1.62	15.83	13.00	1.89	14.64	12.53	2.21
	63 (17.2)††	18.50	14.08	1.01	17.62	13.69	1.19	16.70	13.29	1.39	15.72	12.87	1.63	14.69	12.42	1.90	13.58	11.94	2.22
	62 (16.7)	18.24	17.42	1.01	17.40	16.99	1.19	16.56	16.43	1.39	15.72	15.72	1.62	14.87	14.87	1.90	13.95	13.95	2.22
	57 (13.9)	17.92	17.92	1.01	17.22	17.22	1.19	16.49	16.49	1.39	15.70	15.70	1.63	14.85	14.85	1.90	13.93	13.93	2.21
675	72 (22.2)	22.28	12.35	1.00	21.21	11.97	1.18	20.07	11.56	1.38	18.88	11.14	1.62	17.60	10.69	1.89	16.26	10.22	2.21
	67 (19.4)	20.28	15.56	1.01	19.30	15.16	1.19	18.26	14.74	1.39	17.18	14.31	1.63	16.04	13.85	1.90	14.82	13.36	2.22
	63 (17.2)††	18.83	14.91	1.02	17.91	14.51	1.20	16.96	14.10	1.40	15.96	13.67	1.64	14.88	13.20	1.91	13.76	12.71	2.23
	62 (16.7)	18.66	18.49	1.02	17.85	17.85	1.20	17.08	17.08	1.40	16.24	16.24	1.63	15.34	15.34	1.90	14.36	14.36	2.22
	57 (13.9)	18.57	18.57	1.02	17.83	17.83	1.20	17.05	17.05	1.40	16.22	16.22	1.63	15.32	15.32	1.90	14.35	14.35	2.22
226CNA024—A Outdoor Section With FX4DNF025L Indoor Section																			
700	72 (22.2)	28.14	14.70	1.30	26.53	14.04	1.51	24.88	13.37	1.74	23.19	12.70	2.02	21.40	12.00	2.34	19.51	11.26	2.70
	67 (19.4)	25.57	18.15	1.31	24.12	17.45	1.52	22.62	16.74	1.75	21.06	16.02	2.03	19.44	15.27	2.35	17.73	14.49	2.72
	63 (17.2)††	23.72	17.45	1.32	22.36	16.76	1.53	20.97	16.06	1.76	19.54	15.34	2.04	18.02	14.60	2.35	16.46	13.84	2.72
	62 (16.7)	23.33	21.49	1.32	22.02	20.72	1.53	20.70	19.92	1.76	19.48	18.74	2.04	18.07	18.07	2.35	16.74	16.74	2.72
	57 (13.9)	22.69	22.69	1.33	21.60	21.60	1.53	20.47	20.47	1.76	19.29	19.29	2.04	18.04	18.04	2.35	16.72	16.72	2.72
800	72 (22.2)	28.65	15.44	1.32	26.99	14.77	1.52	25.29	14.09	1.76	23.52	13.39	2.03	21.68	12.66	2.35	19.74	11.94	2.72
	67 (19.4)	26.07	19.36	1.33	24.55	18.63	1.53	23.00	17.90	1.77	21.39	17.14	2.04	19.72	16.37	2.36	17.98	15.55	2.73
	63 (17.2)††	24.19	18.57	1.34	22.79	17.86	1.54	21.35	17.13	1.78	19.85	16.38	2.05	18.31	15.61	2.37	16.69	14.81	2.74
	62 (16.7)	23.91	23.02	1.34	22.58	22.36	1.54	21.30	21.30	1.78	20.04	20.04	2.05	18.71	18.71	2.37	17.30	17.30	2.74
	57 (13.9)	23.64	23.64	1.34	22.47	22.47	1.54	21.27	21.27	1.78	20.01	20.01	2.05	18.69	18.69	2.37	17.28	17.28	2.74
900	72 (22.2)	29.05	16.16	1.33	27.34	15.47	1.54	25.58	14.77	1.77	23.77	14.06	2.05	21.88	13.33	2.37	19.90	12.58	2.74
	67 (19.4)	26.44	20.51	1.34	24.88	19.76	1.55	23.28	18.99	1.79	21.65	18.21	2.06	19.94	17.40	2.38	18.16	16.54	2.75
	63 (17.2)††	24.56	19.64	1.35	23.12	18.90	1.56	21.63	18.14	1.79	20.10	17.36	2.07	18.53	16.56	2.39	16.89	15.71	2.76
	62 (16.7)	24.64	23.75	1.35	23.23	23.23	1.56	21.96	21.96	1.79	20.63	20.63	2.07	19.24	19.24	2.38	17.76	17.76	2.75
	57 (13.9)	24.42	24.42	1.35	23.20	23.20	1.56	21.93	21.93	1.79	20.61	20.61	2.07	19.21	19.21	2.38	17.74	17.74	2.75
226CNA030—A Outdoor Section With FX4DN(B,F)037L Indoor Section																			
875	72 (22.2)	34.74	18.39	1.78	33.09	17.76	1.98	31.33	17.09	2.20	29.42	16.38	2.45	27.35	15.63	2.74	25.12	14.82	3.08
	67 (19.4)	31.56	22.65	1.78	30.07	22.02	1.98	28.48	21.35	2.20	26.78	20.65	2.46	24.93	19.90	2.75	22.94	19.09	3.08
	63 (17.2)††	29.27	21.78	1.78	27.89	21.15	1.98	26.43	20.49	2.21	24.87	19.80	2.46	23.18	19.06	2.75	21.36	18.26	3.08
	62 (16.7)	28.78	26.78	1.78	27.46	26.13	1.98	26.07	25.42	2.21	24.61	24.42	2.46	23.19	23.19	2.75	21.67	21.67	3.08
	57 (13.9)	27.94	27.94	1.78	26.87	26.87	1.98	25.74	25.74	2.21	24.51	24.51	2.46	23.15	23.15	2.75	21.64	21.64	3.08
975	72 (22.2)	35.24	19.11	1.82	33.54	18.47	2.02	31.70	17.79	2.24	29.73	17.07	2.49	27.59	16.30	2.78	25.29	15.48	3.11
	67 (19.4)	32.04	23.83	1.82	30.49	23.19	2.02	28.85	22.51	2.24	27.08	21.79	2.49	25.18	21.02	2.78	23.13	20.18	3.11
	63 (17.2)††	29.72	22.87	1.82	28.30	22.24	2.02	26.78	21.56	2.24	25.17	20.85	2.49	23.44	20.09	2.78	21.56	19.27	3.11
	62 (16.7)	29.32	28.34	1.82	27.97	27.61	2.02	26.69	26.47	2.24	25.26	25.26	2.49	23.81	23.81	2.78	22.21	22.21	3.11
	57 (13.9)	28.87	28.87	1.82	27.74	27.74	2.02	26.53	26.53	2.24	25.23	25.23	2.49	23.78	23.78	2.78	22.18	22.18	3.11
1075	72 (22.2)	35.72	19.87	1.83	33.95	19.23	2.02	32.06	18.54	2.24	30.04	17.81	2.50	27.84	17.03	2.79	25.49	16.20	3.12
	67 (19.4)	32.48	25.03	1.83	30.89	24.39	2.02	29.20	23.70	2.25	27.34	22.93	2.50	25.45	22.16	2.79	23.35	21.30	3.12
	63 (17.2)††	30.16	24.00	1.83	28.69	23.35	2.02	27.13	22.66	2.25	25.48	21.94	2.50	23.70	21.15	2.79	21.79	20.29	3.12
	62 (16.7)	29.89	29.78	1.83	28.59	28.59	2.02	27.33	27.32	2.25	25.93	25.93	2.50	24.41	24.41	2.79	22.73	22.73	3.12
	57 (13.9)	29.73	29.73	1.83	28.55	28.55	2.02	27.28	27.28	2.25	25.90	25.90	2.50	24.39	24.39	2.79	22.71	22.71	3.12

See notes on pg. 15

DETAILED COOLING CAPACITIES# CONTINUED

EVAPORATOR AIR		CONDENSER ENTERING AIR TEMPERATURES ° F (° C)																	
CFM	EWB ° F (° C)	75 (23.9)			85 (29.4)			95 (35)			105 (40.6)			115 (46.1)			125 (51.7)		
		Capacity MBtu/h†		Total System KW**	Capacity MBtu/h†		Total System KW**	Capacity MBtu/h†		Total System KW**	Capacity MBtu/h†		Total System KW**	Capacity MBtu/h†		Total System KW**	Capacity MBtu/h†		Total System KW**
		Total†	Sens†		Total†	Sens†		Total†	Sens†		Total†	Sens†		Total†	Sens†		Total†	Sens†	
226CNA036 – A Outdoor Section With FX4DN(B,F)049L Indoor Section																			
1050	72 (22.2)	42.58	22.75	2.17	40.39	21.89	2.43	38.17	21.02	2.70	35.86	20.13	2.99	33.42	19.21	3.33	30.80	18.24	3.73
	67 (19.4)	38.21	27.66	2.13	36.25	26.81	2.39	34.27	25.96	2.66	32.22	25.09	2.95	30.04	24.18	3.29	27.71	23.21	3.69
	63 (17.2††)	35.13	26.47	2.10	33.34	25.64	2.36	31.53	24.81	2.63	29.66	23.95	2.92	27.68	23.06	3.27	25.63	22.14	3.67
	62 (16.7)	34.44	32.48	2.09	32.73	31.63	2.35	31.00	30.75	2.62	29.26	29.80	2.92	27.57	27.57	3.27	25.85	25.85	3.67
	57 (13.9)	33.22	33.22	2.08	31.88	31.88	2.35	30.52	30.52	2.62	29.08	29.08	2.92	27.53	27.53	3.26	25.81	25.81	3.67
1200	72 (22.2)	43.63	23.99	2.21	41.32	23.10	2.47	38.97	22.21	2.74	36.54	21.29	3.03	33.99	20.35	3.37	31.26	19.35	3.77
	67 (19.4)	39.14	29.58	2.16	37.08	28.70	2.42	35.00	27.83	2.69	32.84	26.93	2.99	30.58	25.99	3.33	29.01	22.44	3.73
	63 (17.2††)	36.00	28.25	2.13	34.11	27.40	2.39	32.21	26.54	2.66	30.25	25.66	2.96	28.18	24.73	3.30	25.96	23.74	3.70
	62 (16.7)	35.41	34.99	2.13	33.64	34.03	2.39	31.94	31.94	2.66	30.38	30.38	2.96	28.69	28.69	3.30	26.84	26.84	3.71
	57 (13.9)	34.81	34.81	2.12	33.36	33.36	2.39	31.88	31.88	2.66	30.33	30.33	2.96	28.66	28.66	3.30	26.81	26.81	3.71
1350	72 (22.2)	44.45	25.15	2.25	42.03	24.25	2.51	39.59	23.34	2.78	37.06	22.41	3.07	34.41	21.44	3.41	31.59	20.43	3.80
	67 (19.4)	39.88	31.41	2.20	37.73	30.52	2.46	35.56	29.61	2.73	33.34	28.69	3.02	30.98	27.71	3.36	28.50	26.67	3.76
	63 (17.2††)	36.68	29.96	2.17	34.71	29.07	2.43	32.75	28.19	2.70	30.72	27.28	2.99	28.58	26.32	3.33	26.31	25.28	3.74
	62 (16.7)	36.31	36.11	2.17	34.67	34.67	2.43	33.09	33.09	2.70	31.42	31.42	3.00	29.63	29.63	3.34	27.67	27.67	3.75
	57 (13.9)	36.17	36.17	2.16	34.61	34.61	2.43	33.04	33.04	2.70	31.38	31.38	3.00	29.59	29.59	3.34	27.64	27.64	3.75
226CPA036 – A Outdoor Section With FX4DN(B,F)049L Indoor Section																			
1050	72 (22.2)	41.09	20.82	2.19	39.13	20.09	2.45	37.16	19.37	2.75	35.04	18.60	3.07	32.80	17.80	3.44	30.40	16.96	3.84
	67 (19.4)	37.34	25.56	2.16	35.60	24.86	2.42	33.78	24.11	2.72	31.84	23.33	3.04	29.77	22.50	3.41	27.58	21.65	3.82
	63 (17.2††)	34.62	24.60	2.14	33.00	23.88	2.41	31.29	23.13	2.70	29.50	22.36	3.03	27.56	21.53	3.39	25.49	20.65	3.80
	62 (16.7)	33.99	30.18	2.14	32.43	29.46	2.40	30.78	28.66	2.70	29.08	27.83	3.02	27.37	27.37	3.39	25.72	25.72	3.81
	57 (13.9)	32.81	32.81	2.13	31.57	31.57	2.40	30.26	30.26	2.69	28.87	28.87	3.02	27.34	27.34	3.39	25.70	25.70	3.81
1200	72 (22.2)	41.88	21.88	2.22	39.90	21.16	2.49	38.33	20.60	2.80	35.60	19.62	3.11	33.29	18.83	3.47	30.79	17.96	3.88
	67 (19.4)	38.12	27.29	2.19	36.28	26.56	2.46	34.40	25.80	2.75	32.38	25.00	3.08	30.25	24.16	3.44	28.05	23.33	3.85
	63 (17.2††)	35.39	26.20	2.17	33.69	25.47	2.44	31.92	24.71	2.73	30.03	23.91	3.06	28.04	23.07	3.42	25.92	22.17	3.83
	62 (16.7)	34.85	32.46	2.17	33.25	31.64	2.44	31.38	31.38	2.73	30.20	30.20	3.07	28.44	28.44	3.43	26.68	26.68	3.84
	57 (13.9)	34.27	34.27	2.17	32.94	32.94	2.43	31.43	31.43	2.73	30.03	30.03	3.06	28.40	28.40	3.43	26.64	26.64	3.84
1350	72 (22.2)	42.55	22.92	2.26	40.48	22.19	2.52	38.33	21.43	2.82	36.09	20.64	3.14	33.66	19.82	3.51	31.11	18.93	3.91
	67 (19.4)	38.73	28.95	2.22	36.85	28.20	2.49	34.90	27.42	2.79	32.84	26.62	3.11	30.64	25.75	3.48	28.29	24.81	3.88
	63 (17.2††)	35.98	27.75	2.21	34.21	27.02	2.47	32.40	26.22	2.76	30.48	25.40	3.09	27.97	24.33	3.45	26.28	23.65	3.87
	62 (16.7)	37.64	28.45	2.22	34.81	31.39	2.48	32.38	32.38	2.76	30.70	30.70	3.09	29.32	29.32	3.46	27.45	27.45	3.88
	57 (13.9)	35.50	35.50	2.20	34.09	34.09	2.47	32.58	32.58	2.77	31.00	31.00	3.10	29.29	29.29	3.46	27.43	27.43	3.88
226CNA042 – A Outdoor Section With FX4DN(B,F)049L Indoor Section																			
1240	72 (22.2)	49.04	25.60	2.46	46.75	24.73	2.77	44.33	23.81	3.13	41.74	22.85	3.54	38.94	21.83	4.01	35.94	20.75	4.53
	67 (19.4)	44.71	31.50	2.45	42.65	30.64	2.76	40.50	29.74	3.12	38.18	28.78	3.52	35.65	27.75	3.99	32.94	26.66	4.52
	63 (17.2††)	41.58	30.36	2.44	39.68	29.50	2.75	37.68	28.61	3.10	35.55	27.66	3.51	33.23	26.64	3.98	30.72	25.55	4.51
	62 (16.7)	40.84	37.24	2.43	39.03	36.36	2.75	37.11	35.41	3.10	35.08	34.36	3.51	32.97	32.97	3.98	30.91	30.91	4.52
	57 (13.9)	39.45	39.45	2.43	38.01	38.01	2.74	36.47	36.47	3.10	34.78	34.78	3.51	32.92	32.92	3.98	30.87	30.87	4.52
1400	72 (22.2)	49.88	26.77	2.49	47.51	25.88	2.80	44.97	24.95	3.16	42.28	23.97	3.57	39.38	22.93	4.03	36.29	21.83	4.56
	67 (19.4)	45.53	33.39	2.48	43.38	32.50	2.79	41.14	31.59	3.15	38.72	30.60	3.55	36.12	29.55	4.02	33.32	28.42	4.55
	63 (17.2††)	42.37	32.12	2.46	40.40	31.24	2.78	38.32	30.33	3.13	36.09	29.35	3.54	33.70	28.31	4.01	31.11	27.18	4.54
	62 (16.7)	41.74	39.72	2.46	39.86	38.75	2.78	37.93	37.64	3.13	36.02	36.02	3.54	34.04	34.04	4.01	31.85	31.85	4.55
	57 (13.9)	40.98	40.98	2.46	39.43	39.43	2.77	37.77	37.77	3.13	35.97	35.97	3.54	33.99	33.99	4.01	31.82	31.82	4.55
1575	72 (22.2)	50.60	27.99	2.52	48.12	27.08	2.84	45.50	26.14	3.19	42.72	25.15	3.60	39.73	24.09	4.07	36.58	22.99	4.59
	67 (19.4)	46.20	35.36	2.51	44.00	34.46	2.82	41.65	33.51	3.18	39.18	32.51	3.59	36.50	31.42	4.05	33.64	30.25	4.59
	63 (17.2††)	43.05	33.97	2.49	41.00	33.06	2.81	38.85	32.12	3.17	36.57	31.12	3.57	34.10	30.04	4.04	31.46	28.86	4.58
	62 (16.7)	42.62	42.11	2.49	40.79	40.79	2.81	39.03	39.03	3.17	37.11	37.11	3.58	35.00	35.00	4.05	32.69	32.69	4.58
	57 (13.9)	42.38	42.38	2.49	40.73	40.73	2.81	38.98	38.98	3.17	37.06	37.06	3.58	34.96	34.96	4.05	32.66	32.66	4.58

See notes on pg. 15

DETAILED COOLING CAPACITIES# CONTINUED

EVAPORATOR AIR		CONDENSER ENTERING AIR TEMPERATURES ° F (° C)																	
CFM	EWB ° F (° C)	75 (23.9)			85 (29.4)			95 (35)			105 (40.6)			115 (46.1)			125 (51.7)		
		Capacity MBtu/h†		Total System KW**	Capacity MBtu/h†		Total System KW**	Capacity MBtu/h†		Total System KW**	Capacity MBtu/h†		Total System KW**	Capacity MBtu/h†		Total System KW**	Capacity MBtu/h†		Total System KW**
		Total†	Sens‡		Total†	Sens‡		Total†	Sens‡		Total†	Sens‡		Total†	Sens‡		Total†	Sens‡	
226CNA048—A Outdoor Section With FX4DN(B,F)061L Indoor Section																			
1420	72 (22.2)	58.07	29.24	2.80	55.36	29.79	3.22	52.51	30.20	3.71	49.43	30.41	4.27	46.11	30.42	4.93	42.57	30.23	5.67
	67 (19.4)	53.00	36.08	2.79	50.57	37.01	3.21	48.00	37.79	3.69	45.23	38.38	4.26	42.21	38.75	4.91	38.97	38.89	5.65
	63 (17.2)††	49.29	34.76	2.78	47.05	35.64	3.19	44.69	36.36	3.68	42.13	36.89	4.24	39.35	37.20	4.89	36.34	37.26	5.64
	62 (16.7)	48.39	42.71	2.78	46.26	43.99	3.19	43.97	45.08	3.68	41.55	45.90	4.24	39.34	45.23	4.89	36.61	36.61	5.64
	57 (13.9)	46.84	46.84	2.77	45.13	45.13	3.19	43.29	43.29	3.67	41.27	41.27	4.24	39.04	39.04	4.89	36.56	36.56	5.64
1600	72 (22.2)	59.07	30.58	2.83	56.23	31.18	3.25	53.24	31.63	3.74	50.06	31.90	4.31	46.62	31.95	4.96	42.99	31.81	5.70
	67 (19.4)	53.94	38.22	2.82	51.41	39.25	3.24	48.73	40.13	3.73	45.85	40.80	4.29	42.74	41.25	4.95	39.40	41.46	5.69
	63 (17.2)††	50.21	36.77	2.81	47.88	37.73	3.23	45.42	38.54	3.72	42.77	39.14	4.28	39.90	39.52	4.93	36.79	39.63	5.68
	62 (16.7)	49.44	45.54	2.81	47.22	46.87	3.23	45.37	46.67	3.72	42.73	42.73	4.28	40.34	40.34	4.93	37.71	37.71	5.68
	57 (13.9)	48.62	48.62	2.81	46.78	46.78	3.23	44.83	44.83	3.71	42.67	42.67	4.28	40.29	40.29	4.93	37.66	37.66	5.68
1800	72 (22.2)	59.90	31.99	2.87	56.96	32.65	3.29	53.86	33.16	3.78	50.55	33.48	4.35	47.05	33.60	5.00	43.33	33.52	5.74
	67 (19.4)	54.77	40.52	2.85	52.13	41.65	3.28	49.35	42.61	3.77	46.39	43.38	4.33	43.18	43.90	4.99	39.78	44.18	5.73
	63 (17.2)††	51.02	38.91	2.85	48.60	39.95	3.26	46.06	40.85	3.75	43.32	41.54	4.32	40.36	41.97	4.97	37.19	42.14	5.72
	62 (16.7)	50.90	47.27	2.85	48.40	48.40	3.26	46.31	46.31	3.75	44.01	44.01	4.32	41.48	41.48	4.98	38.71	38.71	5.73
	57 (13.9)	50.29	50.29	2.84	48.34	48.34	3.26	46.25	46.25	3.75	43.96	43.96	4.32	41.43	41.43	4.98	38.67	38.67	5.73
226CPA048—A Outdoor Section With FX4DN(B,F)061L Indoor Section																			
1400	72 (22.2)	57.52	29.31	3.10	54.78	28.29	3.44	52.02	27.26	3.82	48.99	26.16	4.25	45.76	25.00	4.73	42.33	23.79	5.26
	67 (19.4)	52.42	36.03	3.07	49.93	35.01	3.41	47.41	33.96	3.80	44.69	32.87	4.23	41.73	31.69	4.72	38.58	30.45	5.27
	63 (17.2)††	48.66	34.69	3.05	46.42	33.69	3.39	44.04	32.64	3.78	41.50	31.54	4.21	38.77	30.37	4.70	35.84	29.13	5.26
	62 (16.7)	47.88	42.57	3.05	45.58	41.51	3.39	43.29	40.41	3.77	40.88	39.21	4.21	38.44	38.44	4.70	36.06	36.06	5.26
	57 (13.9)	46.08	46.08	3.04	44.32	44.32	3.38	42.53	42.53	3.77	40.54	40.54	4.21	38.38	38.38	4.70	36.03	36.03	5.26
1600	72 (22.2)	58.61	30.79	3.14	55.77	29.77	3.47	52.89	28.72	3.85	49.75	27.60	4.28	46.39	26.42	4.76	42.85	25.19	5.30
	67 (19.4)	53.49	38.43	3.11	50.96	37.41	3.45	48.28	36.33	3.83	45.43	35.20	4.27	42.37	34.00	4.75	39.11	32.72	5.30
	63 (17.2)††	49.87	37.03	3.09	47.33	35.92	3.43	44.90	34.85	3.82	42.26	33.72	4.25	39.43	32.52	4.74	36.39	31.23	5.29
	62 (16.7)	48.94	45.71	3.09	46.70	44.59	3.43	44.37	44.37	3.81	42.22	42.22	4.25	39.89	39.89	4.74	37.35	37.35	5.30
	57 (13.9)	48.09	48.09	3.08	46.25	46.25	3.43	44.29	44.29	3.81	42.16	42.16	4.25	39.84	39.84	4.74	37.30	37.30	5.30
1800	72 (22.2)	59.49	32.23	3.18	56.59	31.19	3.51	53.53	30.11	3.89	50.29	28.97	4.32	46.87	27.81	4.80	43.24	26.57	5.33
	67 (19.4)	54.22	40.67	3.16	51.69	39.68	3.49	48.93	38.59	3.87	46.00	37.44	4.30	42.85	36.19	4.79	39.53	34.88	5.33
	63 (17.2)††	50.57	39.13	3.13	48.07	38.06	3.47	45.56	36.96	3.85	42.84	35.80	4.29	39.92	34.56	4.78	36.83	33.22	5.33
	62 (16.7)	50.54	47.08	3.13	47.86	47.86	3.47	45.81	45.81	3.86	43.55	43.55	4.29	41.08	41.08	4.78	38.40	38.40	5.33
	57 (13.9)	49.80	49.80	3.13	47.77	47.77	3.47	45.75	45.75	3.86	43.49	43.49	4.29	41.03	41.03	4.78	38.36	38.36	5.33

See notes on pg. 15

DETAILED COOLING CAPACITIES# CONTINUED

EVAPORATOR AIR		CONDENSER ENTERING AIR TEMPERATURES ° F (° C)																	
CFM	EWB ° F (° C)	75 (23.9)			85 (29.4)			95 (35)			105 (40.6)			115 (46.1)			125 (51.7)		
		Capacity MBtuH†		Total System KW**	Capacity MBtuH†		Total System KW**	Capacity MBtuH†		Total System KW**	Capacity MBtuH†		Total System KW**	Capacity MBtuH†		Total System KW**	Capacity MBtuH†		Total System KW**
		Total†	Sens‡		Total†	Sens‡		Total†	Sens‡		Total†	Sens‡		Total†	Sens‡		Total†	Sens‡	
226CNA060—A Outdoor Section With FX4DN(B,F)061L Indoor Section																			
1600	72 (22.2)	67.41	34.75	3.24	63.92	33.45	3.71	60.21	32.09	4.25	56.21	30.64	4.87	51.85	29.08	5.58	47.29	27.48	6.39
	67 (19.4)	61.41	42.78	3.23	58.31	41.51	3.69	55.00	40.18	4.23	51.44	38.76	4.85	47.09	37.03	5.55	43.40	35.59	6.38
	63 (17.2)††	57.06	41.22	3.21	54.24	39.98	3.68	51.22	38.66	4.22	47.58	37.09	4.83	44.36	35.73	5.55	40.59	34.13	6.37
	62 (16.7)	56.01	50.59	3.21	53.30	49.32	3.68	50.38	47.94	4.22	47.07	46.25	4.83	44.15	44.15	5.55	41.01	41.01	6.38
	57 (13.9)	54.03	54.03	3.20	51.89	51.89	3.67	49.54	49.54	4.21	46.96	46.96	4.84	44.10	44.10	5.55	40.97	40.97	6.38
1750	72 (22.2)	68.27	35.89	3.27	64.69	34.58	3.74	60.82	33.17	4.28	56.74	31.73	4.90	52.25	30.15	5.61	47.62	28.54	6.43
	67 (19.4)	62.25	44.63	3.26	59.04	43.34	3.73	55.63	41.99	4.27	51.94	40.54	4.89	47.24	38.68	5.59	43.73	37.32	6.42
	63 (17.2)††	57.89	42.95	3.25	54.95	41.68	3.72	51.83	40.35	4.25	48.43	38.90	4.88	44.79	37.36	5.59	40.91	35.72	6.41
	62 (16.7)	56.91	53.05	3.24	54.11	51.71	3.71	51.17	50.18	4.25	48.17	48.17	4.88	45.13	45.13	5.59	41.87	41.87	6.42
	57 (13.9)	55.57	55.57	3.24	53.30	53.30	3.71	50.83	50.83	4.25	48.05	48.05	4.87	45.10	45.10	5.59	41.82	41.82	6.42
2000	72 (22.2)	69.42	37.71	3.33	65.65	36.37	3.80	61.66	34.96	4.34	57.41	33.51	4.96	52.76	31.87	5.68	48.01	30.25	6.49
	67 (19.4)	63.34	47.60	3.32	59.99	46.28	3.79	56.42	44.88	4.33	52.60	43.39	4.95	48.44	41.76	5.66	44.15	40.05	6.49
	63 (17.2)††	58.94	45.70	3.30	55.88	44.41	3.77	52.62	43.03	4.31	49.13	41.55	4.94	45.33	39.94	5.65	41.36	38.22	6.48
	62 (16.7)	58.21	56.77	3.30	55.41	55.41	3.77	52.72	52.72	4.32	49.80	49.80	4.94	46.54	46.54	5.66	43.04	43.04	6.48
	57 (13.9)	57.76	57.76	3.30	55.32	55.32	3.77	52.66	52.66	4.32	49.72	49.72	4.94	46.48	46.48	5.66	43.00	43.00	6.48
226CPA060—A Outdoor Section With FX4DN(B,F)061L Indoor Section																			
1750	72 (22.2)	73.01	38.41	3.37	69.22	36.98	3.73	65.11	35.45	4.14	60.71	33.83	4.60	55.97	32.12	5.11	51.02	30.35	5.67
	67 (19.4)	66.45	47.62	3.34	63.04	46.20	3.70	59.39	44.70	4.11	55.42	43.08	4.57	51.20	41.38	5.08	46.74	39.58	5.65
	63 (17.2)††	61.67	45.79	3.32	58.57	44.40	3.68	55.20	42.90	4.09	51.58	41.31	4.55	47.71	39.63	5.06	43.65	37.87	5.64
	62 (16.7)	60.61	56.52	3.31	57.63	55.04	3.67	54.44	53.38	4.08	51.16	51.16	4.55	47.97	47.97	5.07	44.57	44.57	5.64
	57 (13.9)	59.01	59.01	3.30	56.62	56.62	3.67	53.97	53.97	4.08	51.09	51.09	4.55	47.86	47.86	5.06	44.52	44.52	5.64
2000	72 (22.2)	74.29	40.34	3.44	70.32	38.88	3.80	66.03	37.32	4.20	61.41	35.66	4.66	56.55	33.93	5.17	51.48	32.15	5.73
	67 (19.4)	67.66	50.77	3.40	64.11	49.32	3.77	60.27	47.76	4.17	56.16	46.10	4.63	51.79	44.34	5.14	47.24	42.48	5.71
	63 (17.2)††	62.85	48.72	3.38	59.61	47.29	3.74	56.09	45.75	4.15	52.33	44.11	4.61	48.32	42.36	5.13	44.14	40.52	5.70
	62 (16.7)	62.01	60.52	3.38	59.29	57.98	3.74	56.04	56.04	4.15	52.92	52.92	4.61	49.52	49.52	5.13	45.87	45.87	5.71
	57 (13.9)	61.40	61.40	3.37	58.81	58.81	3.74	55.97	55.97	4.15	52.85	52.85	4.61	49.43	49.43	5.13	45.83	45.83	5.71
2250	72 (22.2)	75.23	42.18	3.50	71.12	40.69	3.86	66.71	39.11	4.26	61.98	37.43	4.72	56.96	35.67	5.23	51.79	33.88	5.79
	67 (19.4)	68.58	53.78	3.47	64.89	52.27	3.83	60.94	50.68	4.23	56.73	48.97	4.69	52.22	47.11	5.20	47.60	45.12	5.77
	63 (17.2)††	63.75	51.50	3.44	60.39	50.02	3.80	56.76	48.45	4.21	52.88	46.74	4.67	48.00	44.54	5.17	44.53	42.90	5.76
	62 (16.7)	63.47	63.47	3.44	60.70	60.70	3.81	57.66	57.66	4.22	54.36	54.36	4.68	50.71	50.71	5.20	46.90	46.90	5.77
	57 (13.9)	63.38	63.38	3.44	60.62	60.62	3.81	57.60	57.60	4.22	54.31	54.31	4.68	50.71	50.71	5.19	46.85	46.85	5.77

Detailed cooling capacities are based on indoor and outdoor unit at the same elevation per AHRI standard 210/240-08. If additional tubing length and/or indoor unit is located above outdoor unit, a slight variation in capacity may occur.

† Total and sensible capacities are net capacities. Blower motor heat has been subtracted.

‡ Sensible capacities shown are based on 80°F (27°C) entering air at the indoor coil. For sensible capacities at other than 80°F (27°C), deduct 835 BtuH (245 kW) per 1000 CFM (480 L/S) of indoor coil air for each degree below 80°F (27°C), or add 835 BtuH (245 kW) per 1000 CFM (480 L/S) of indoor coil air per degree above 80°F (27°C).

** System kw is total of indoor and outdoor unit kilowatts.

†† At TVA rating indoor condition (75°F edb/63°F ewb). All other indoor air temperatures are at 80°F edb.

NOTE: When the required data falls between the published data, interpolation may be performed. Extrapolation is not an acceptable practice.

EWB — Entering Wet Bulb

HEAT PUMP HEATING PERFORMANCE CONTINUED

INDOOR AIR		OUTDOOR COIL ENTERING AIR TEMPERATURES ° F (° C)																							
		-3 (-19.4)			7 (-13.9)			17 (-8.3)			27 (-2.8)			37 (2.8)			47 (8.3)			57 (13.9)			67 (19.4)		
EDB ° F (° C)	CFM	Capacity MBtuh		Total Sys. KW†	Capacity MBtuh		Total Sys. KW†	Capacity MBtuh		Total Sys. KW†	Capacity MBtuh		Total Sys. KW†	Capacity MBtuh		Total Sys. KW†	Capacity MBtuh		Total Sys. KW†	Capacity MBtuh		Total Sys. KW†	Capacity MBtuh		Total Sys. KW†
		Total	Integ*		Total	Integ*		Total	Integ*		Total	Integ*		Total	Integ*		Total	Integ*		Total	Integ*		Total	Integ*	
226CNA042-A Outdoor Section With FX4DN(B,F)049L Indoor Section																									
65 (18.3)	1240	17.06	15.70	2.29	21.26	19.54	2.42	25.65	23.38	2.51	30.43	27.03	2.63	35.69	32.48	2.76	41.43	41.43	2.90	47.26	47.26	3.06	53.52	53.52	3.22
	1400	17.13	15.76	2.29	21.31	19.59	2.41	25.67	23.41	2.49	30.46	27.06	2.60	35.80	32.58	2.71	41.54	41.54	2.84	47.45	47.45	2.97	53.86	53.86	3.11
	1575	17.21	15.83	2.29	21.38	19.64	2.39	25.71	23.44	2.47	30.51	27.09	2.57	35.91	32.68	2.68	41.66	41.66	2.79	47.65	47.65	2.91	54.19	54.19	3.04
70 (21.1)	1240	16.95	15.59	2.41	20.99	19.29	2.55	25.40	23.16	2.64	30.14	26.77	2.77	35.29	32.11	2.90	41.00	41.00	3.05	46.69	46.69	3.21	52.84	52.84	3.37
	1400	17.03	15.67	2.41	20.84	19.15	2.53	25.43	23.18	2.61	30.17	26.79	2.73	35.34	32.16	2.85	40.87	40.87	2.98	46.88	46.88	3.12	53.33	53.33	3.27
	1575	17.12	15.75	2.41	20.90	19.21	2.52	25.47	23.22	2.60	30.21	26.83	2.70	35.39	32.21	2.81	40.97	40.97	2.93	47.07	47.07	3.05	53.65	53.65	3.19
75 (23.9)	1240	16.67	15.34	2.53	20.55	18.89	2.67	25.15	22.93	2.78	29.84	26.50	2.91	34.92	31.78	3.06	40.36	40.36	3.20	46.14	46.14	3.36	52.31	52.31	3.54
	1400	16.73	15.39	2.53	20.60	18.93	2.65	25.18	22.96	2.75	29.87	26.53	2.87	34.96	31.81	3.00	40.44	40.44	3.13	46.32	46.32	3.27	52.63	52.63	3.43
	1575	16.81	15.47	2.53	20.66	18.99	2.65	25.21	22.99	2.74	29.91	26.56	2.84	35.01	31.86	2.96	40.54	40.54	3.08	46.50	46.50	3.20	52.94	52.94	3.34
226CNA048-A Outdoor Section With FX4DN(B,F)061L Indoor Section																									
65 (18.3)	1420	20.76	19.10	2.81	25.15	23.11	2.91	29.87	27.23	3.02	35.07	31.15	3.13	40.98	37.30	3.25	46.78	46.78	3.38	53.42	53.42	3.52	60.31	60.31	3.67
	1600	20.83	19.16	2.81	25.20	23.16	2.90	29.90	27.27	3.00	35.27	31.33	3.10	40.86	37.18	3.20	47.27	47.27	3.31	53.63	53.63	3.43	60.65	60.65	3.56
	1800	20.91	19.24	2.82	25.26	23.22	2.89	29.96	27.32	2.98	35.30	31.35	3.07	40.88	37.20	3.17	47.07	47.07	3.26	53.95	53.95	3.37	61.12	61.12	3.48
70 (21.1)	1420	20.52	18.88	2.95	24.93	22.91	3.05	29.60	26.99	3.17	34.74	30.86	3.29	40.32	36.69	3.41	46.50	46.50	3.55	52.76	52.76	3.69	59.42	59.42	3.84
	1600	20.58	18.94	2.94	24.98	22.95	3.04	29.64	27.02	3.14	34.79	30.90	3.25	40.60	36.95	3.36	46.40	46.40	3.48	53.01	53.01	3.60	59.87	59.87	3.73
	1800	20.66	19.01	2.95	25.04	23.01	3.03	29.69	27.07	3.13	34.84	30.94	3.22	40.67	37.01	3.32	46.55	46.55	3.42	53.27	53.27	3.53	60.29	60.29	3.64
75 (23.9)	1420	20.29	18.66	3.09	24.72	22.71	3.20	29.34	26.75	3.32	34.42	30.57	3.45	39.98	36.38	3.58	46.00	46.00	3.72	52.12	52.12	3.87	58.62	58.62	4.02
	1600	20.35	18.72	3.08	24.76	22.76	3.18	29.38	26.78	3.29	34.46	30.61	3.41	40.05	36.44	3.52	45.96	45.96	3.64	52.36	52.36	3.77	59.04	59.04	3.91
	1800	20.43	18.79	3.09	24.82	22.81	3.18	29.43	26.83	3.28	34.51	30.65	3.38	40.25	36.63	3.48	46.31	46.31	3.59	52.60	52.60	3.70	59.45	59.45	3.82
226CPA048-A Outdoor Section With FX4DN(B,F)061L Indoor Section																									
65 (18.3)	1400	18.88	17.37	2.63	23.37	21.48	2.73	28.32	25.82	2.85	33.97	30.17	3.00	40.24	36.62	3.15	45.22	45.22	3.29	38.66	38.66	3.11	38.71	38.71	3.10
	1600	19.18	17.64	2.63	23.61	21.70	2.71	28.56	26.04	2.82	34.33	30.49	2.97	40.35	36.72	3.10	42.44	42.44	3.15	39.28	39.28	3.06	40.26	40.26	3.07
	1800	19.38	17.83	2.63	23.82	21.89	2.71	28.81	26.27	2.81	34.72	30.84	2.95	40.29	36.66	3.08	39.23	39.23	3.04	38.53	38.53	3.01	36.95	36.95	2.98
70 (21.1)	1400	17.92	16.49	2.74	22.93	21.07	2.87	27.78	25.32	2.99	33.41	29.68	3.14	39.78	36.20	3.31	45.77	45.77	3.49	42.51	42.51	3.37	41.64	41.64	3.34
	1600	18.19	16.73	2.74	23.15	21.27	2.85	28.08	25.60	2.96	33.76	29.98	3.11	39.85	36.27	3.25	43.05	43.05	3.34	40.46	40.46	3.25	39.42	39.42	3.22
	1800	18.43	16.95	2.75	23.37	21.47	2.85	28.34	25.84	2.95	34.05	30.24	3.10	39.91	36.32	3.23	40.18	40.18	3.22	39.06	39.06	3.18	38.04	38.04	3.16
75 (23.9)	1400	17.22	15.85	2.87	22.46	20.64	3.01	27.32	24.91	3.14	32.85	29.18	3.30	39.33	35.79	3.47	45.48	45.48	3.66	43.26	43.26	3.57	41.84	41.84	3.53
	1600	17.47	16.07	2.87	22.68	20.84	3.00	27.58	25.15	3.11	33.19	29.47	3.26	39.41	35.86	3.42	43.59	43.59	3.53	41.20	41.20	3.44	39.79	39.79	3.41
	1800	17.67	16.26	2.88	22.90	21.05	2.99	27.81	25.36	3.10	33.49	29.75	3.24	39.52	35.96	3.37	41.46	41.46	3.43	39.22	39.22	3.36	38.14	38.14	3.33

See notes on pg. 18

HEAT PUMP HEATING PERFORMANCE CONTINUED

INDOOR AIR		OUTDOOR COIL ENTERING AIR TEMPERATURES ° F (° C)																							
		-3 (-19.4)			7 (-13.9)			17 (-8.3)			27 (-2.8)			37 (2.8)			47 (8.3)		57 (13.9)		67 (19.4)				
EDB ° F (° C)	CFM	Capacity MBtuh		Total Sys. KW†	Capacity MBtuh		Total Sys. KW†	Capacity MBtuh		Total Sys. KW†	Capacity MBtuh		Total Sys. KW†	Capacity MBtuh		Total Sys. KW†	Capacity MBtuh		Total Sys. KW†	Capacity MBtuh		Total Sys. KW†			
		Total	Integ*		Total	Integ*		Total	Integ*		Total	Integ*		Total	Integ*		Total	Integ*		Total	Integ*		Total	Integ*	
226CNA060—A Outdoor Section With FX4DN(B,F)061L Indoor Section																									
65 (18.3)	1600	22.25	20.47	3.02	28.49	26.18	3.20	34.05	31.05	3.37	40.36	35.84	3.55	47.55	43.27	3.77	55.86	55.86	4.04	65.60	65.60	4.39	76.29	76.29	4.72
	1750	22.47	20.67	3.02	28.69	26.36	3.20	34.27	31.24	3.35	40.64	36.09	3.53	47.93	43.61	3.74	56.31	56.31	3.99	66.14	66.14	4.33	77.38	77.38	4.70
	2000	22.78	20.96	3.04	28.96	26.61	3.20	34.61	31.55	3.35	41.22	36.61	3.51	48.45	44.09	3.70	56.96	56.96	3.95	66.88	66.88	4.29	77.72	77.72	4.62
70 (21.1)	1600	21.64	19.91	3.15	27.97	25.70	3.35	33.60	30.64	3.53	39.81	35.36	3.72	46.86	42.64	3.94	55.00	55.00	4.22	64.59	64.59	4.58	75.28	75.28	4.96
	1750	21.85	20.10	3.16	28.24	25.95	3.35	33.81	30.83	3.51	40.09	35.61	3.69	47.23	42.98	3.91	55.47	55.47	4.17	65.15	65.15	4.52	75.93	75.93	4.87
	2000	22.16	20.39	3.18	28.55	26.24	3.36	34.16	31.15	3.50	40.50	35.97	3.67	47.75	43.45	3.87	56.10	56.10	4.13	65.86	65.86	4.47	76.69	76.69	4.82
75 (23.9)	1600	20.96	19.28	3.30	26.57	24.42	3.48	33.14	30.21	3.70	39.27	34.88	3.90	46.21	42.05	4.13	54.16	54.16	4.41	63.56	63.56	4.78	74.40	74.40	5.24
	1750	21.17	19.48	3.31	26.82	24.65	3.48	33.38	30.43	3.68	39.55	35.12	3.87	46.56	42.37	4.09	54.62	54.62	4.36	64.13	64.13	4.72	74.88	74.88	5.11
	2000	21.49	19.77	3.33	27.21	25.00	3.49	33.69	30.72	3.67	39.95	35.48	3.85	47.05	42.82	4.05	55.25	55.25	4.31	64.85	64.85	4.67	75.64	75.64	5.03
226CPA060—A Outdoor Section With FX4DN(B,F)061L Indoor Section																									
65 (18.3)	1800	25.74	23.69	3.00	32.74	30.09	3.15	39.40	35.92	3.29	47.00	41.74	3.47	55.70	50.69	3.72	65.48	65.48	4.07	76.29	76.29	4.42	88.11	88.11	4.98
	2000	26.02	23.94	3.02	33.02	30.34	3.16	39.72	36.22	3.29	47.36	42.06	3.47	56.06	51.02	3.72	65.80	65.80	4.03	76.43	76.43	4.44	88.16	88.16	4.99
	2200	26.28	24.18	3.04	33.27	30.57	3.17	40.02	36.49	3.30	47.68	42.34	3.47	56.34	51.27	3.74	66.00	66.00	4.03	76.50	76.50	4.46	88.16	88.16	4.44
70 (21.1)	1800	25.03	23.03	3.14	32.19	29.58	3.30	38.82	35.39	3.45	46.33	41.15	3.63	54.86	49.93	3.88	64.53	64.53	4.24	75.35	75.35	4.59	87.10	87.10	5.17
	2000	25.32	23.30	3.16	32.48	29.85	3.31	39.14	35.69	3.45	46.69	41.47	3.63	55.25	50.28	3.88	64.93	64.93	4.24	75.53	75.53	4.60	87.20	87.20	5.18
	2200	25.59	23.54	3.18	32.75	30.10	3.32	39.43	35.95	3.46	47.01	41.75	3.63	55.54	50.54	3.90	65.11	65.11	4.22	75.60	75.60	4.62	87.23	87.23	5.20
75 (23.9)	1800	24.28	22.33	3.28	30.97	28.46	3.44	38.24	34.87	3.62	45.66	40.55	3.81	54.05	49.19	4.05	63.56	63.56	4.42	74.39	74.39	4.79	86.07	86.07	5.37
	2000	24.57	22.61	3.30	31.39	28.85	3.45	38.56	35.16	3.62	46.02	40.87	3.79	54.43	49.53	4.05	63.92	63.92	4.42	74.60	74.60	4.79	86.19	86.19	5.37
	2200	24.84	22.85	3.33	32.14	29.54	3.48	38.85	35.42	3.62	46.34	41.16	3.80	54.73	49.81	4.06	64.02	64.02	4.42	74.77	74.77	4.81	86.26	86.26	5.40

NOTE: When the required data falls between the published data, interpolation may be performed. Extrapolation is not an acceptable practice.

* The Btuh heating capacity values shown are net integrated values from which the defrost effect has been subtracted. The Btuh heating from supplement heaters should be added to those values to obtain total system capacity.

† The kW values include the compressor, outdoor fan motor, and indoor blower motor. The kW from supplement heaters should be added to these values to obtain total system kilowatts.

EDB — Entering Dry Bulb

GUIDE SPECIFICATIONS

GENERAL

System Description

Outdoor-mounted, air-cooled, split-system heat pump unit suitable for ground or rooftop installation. Unit consists of a hermetic compressor, an air-cooled coil, forward-swept blade propeller-type condenser fan, and a control box. Unit will discharge supply air upward as shown on contract drawings. Unit will be used in a refrigeration circuit to match up to a packaged fan coil or coil unit.

Quality Assurance

- Unit will be rated in accordance with the latest edition of AHRI Standard 240.
- Unit will be certified for capacity and efficiency, and listed in the latest AHRI directory.
- Unit construction will comply with latest edition of ASHRAE and with NEC.
- Unit will be constructed in accordance with UL standards and will carry the UL label of approval. Unit will have C-UL approval.
- Unit cabinet will be capable of withstanding Federal Test Method Standard No. 141 (Method 6061) 500-hr salt spray test.
- Air-cooled condenser coils are pressure tested and the outdoor units are leak tested.
- Unit constructed in ISO9001 approved facility.

Delivery, Storage, and Handling

- Unit will be shipped as single package only and is stored and handled per unit manufacturer's recommendations.

Warranty (for inclusion by specifying engineer)

- U.S. and Canada only.

PRODUCTS

Equipment

- Factory-assembled, single-piece, air-cooled heat pump unit. Contained within the unit enclosure is all factory wiring, piping, controls, compressor, refrigerant charge Puron® (R-410A) refrigerant, and special features required prior to field start-up.

Unit Cabinet

- Unit cabinet will be constructed of galvanized steel, bonderized, and coated with a powder coat paint.

Fans

- Condenser fan will be direct-drive propeller type, forward swept blade, discharging air upward.

AIR-COOLED, SPLIT-SYSTEM HEAT PUMP

226CNA

1-1/2 TO 5 NOMINAL TONS

- Condenser fan motors will be totally enclosed, 1-phase type with class B insulation and permanently lubricated.
- Shafts will be corrosion resistant.
- Fan blades will be statically and dynamically balanced.
- Condenser fan openings will be equipped with coated steel wire safety guards.

Compressor

- Compressor will be hermetically sealed.
- Compressor will be mounted on rubber vibration isolators.
- Compressor will be covered with a sound absorbing blanket.

Condenser Coil

- Condenser coil will be air cooled.
- Coil will be constructed of aluminum fins mechanically bonded to copper tubes which are then cleaned, dehydrated, and sealed.

Refrigeration Components

- Refrigeration circuit components will include liquid-line back-seating shutoff valve with sweat connections, vapor-line back-seating shutoff valve with sweat connections, system charge of Puron® (R-410A) refrigerant, POE compressor oil, accumulator, and reversing valve.
- Unit will be equipped with high-pressure switch, loss-of-charge switch, and filter drier for Puron® refrigerant.

Operating Characteristics

- The capacity of the unit will meet or exceed _____ Btuh at a suction temperature of _____ °F (°C). The power consumption at full load will not exceed _____ kW.
- Combination of the unit and the evaporator or fan coil unit will have a total net cooling capacity of _____ Btuh or greater at conditions of _____ CFM entering air temperature at the evaporator at _____ °F (°C) wet bulb and _____ °F (°C) dry bulb, and air entering the unit at _____ °F (°C).
- The system will have a SEER of _____ Btuh/watt or greater at DOE conditions.

Electrical Requirements

- Nominal unit electrical characteristics will be _____ v, single phase, 60 hz. The unit will be capable of satisfactory operation within voltage limits of _____ v to _____ v.
- Unit electrical power will be single point connection.
- Control circuit will be 24v.

Special Features

- Refer to section of this literature identifying accessories and descriptions for specific features and available enhancements.

SYSTEM DESIGN SUMMARY

1. Intended for outdoor installation with free air inlet and outlet. Outdoor fan external static pressure available is less than 0.01-in. wc.
2. Minimum outdoor operating air temperature without low-ambient operation accessory is 55°F (12.8°C).
3. The maximum outdoor operating ambient in cooling mode is 125°F (51.67°C) when operating voltage is 230v. For 208v applications, the maximum outdoor ambient is 120°F (48.9°C).
4. Minimum outdoor operating air temperature for heating mode is -10°F (-23°C).
5. Maximum outdoor operating air temperature for heating mode is 66°F (18.9°C).
6. For reliable operation, unit should be level in all horizontal planes.
7. For interconnecting refrigerant tube lengths greater than 80 ft (23.4 m) and/or elevation differences between indoor and outdoor units greater than 20 ft (6.1 m), consult Residential Piping and Longline Guideline and Service Manual available from equipment distributor.
8. If any refrigerant tubing is buried, provide a 6 in. (152.4 mm) vertical rise to the valve connections at the unit. Refrigerant tubing lengths up to 36 in. (914.4 mm) may be buried without further consideration. Do not bury refrigerant lines longer than 36 in. (914.4 mm).
9. Use only copper wire for electric connection at unit. Aluminum and clad aluminum are not acceptable for the type of connector provided.
10. Do not apply capillary tube indoor coils to these units.
11. Factory-supplied filter drier must be installed.